



MOTOROLA

Order this document by MC3334/D

MC3334 MCC3334 MCCF3334

High Energy Ignition Circuit

This device is designed to use the signal from a retractor type ignition pickup to produce a well controlled output from a power Darlington output transistor.

- Very Low Peripheral Component Count
- No Critical System Resistors
- Wide Supply Voltage Operating Range (4.0 V to 24 V)
- Overvoltage Shutdown (30 V)
- Dwell Automatically Adjusts to Produce Optimum Stored Energy without Waste
- Externally Adjustable Peak Current
- Available in Chip and Flip-Chip Form
- Transient Protected Inputs and Outputs

HIGH ENERGY IGNITION CIRCUIT

SEMICONDUCTOR TECHNICAL DATA

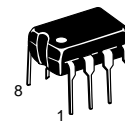

P SUFFIX
PLASTIC PACKAGE
CASE 626

D SUFFIX
PLASTIC PACKAGE
CASE 751
(SO-8)



MAXIMUM RATINGS

Rating	Symbol	Value	Unit
Power Supply Voltage—Steady State Transient 300 ms or less	V _{bat}	24 90	V
Output Sink Current—Steady State Transient 300 ms or less	I _{O(Sink)}	300 1.0	mA A
Junction Temperature	T _{J(max)}	150	°C
Operating Temperature Range	T _A	-40 to +125	°C
Storage Temperature Range	T _{stg}	-65 to +150	°C
Power Dissipation, Plastic Package, Case 626 Derate above 25°C	P _D	1.25 10	W mW/°C

ORDERING INFORMATION

Device	Operating Temperature Range	Package
MC3334P	T _A = -40° to +125°C	Plastic DIP
MC3334D		SO-8
MCC3334		Chip
MCCF3334		Flip-Chip

Figure 1. Block Diagram and Typical Application

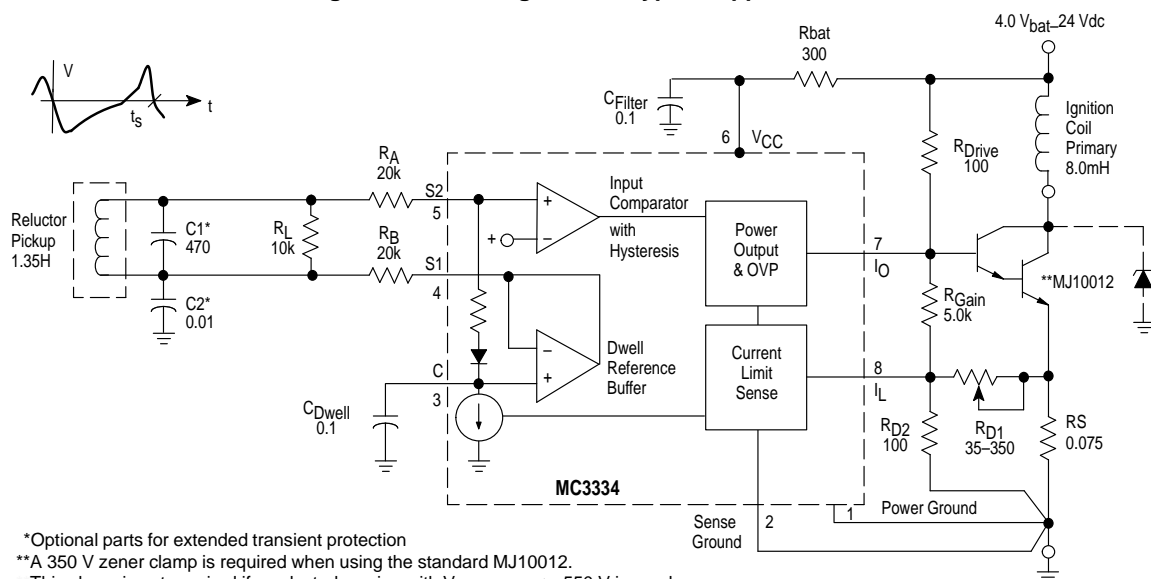

MC3334 MCC3334 MCCF3334

ELECTRICAL CHARACTERISTICS ($T_A = -40^\circ$ to $+125^\circ\text{C}$, $V_{\text{bat}} = 13.2$ Vdc, circuit of Figure 1, unless otherwise noted.)

Characteristics	Symbol	Min	Typ	Max	Unit
Internal Supply Voltage, Pin 6 $V_{\text{bat}} = 4.0$ Vdc 8.0 Vdc 12.0 14.0	V_{CC}	–	3.5 7.2 10.4 11.8	–	Vdc
Ignition Coil Current Peak, Cranking RPM 2.0 Hz to 27 Hz $V_{\text{bat}} = 4.0$ Vdc 6.0 8.0 10.0	$I_o(\text{pk})$	3.0 4.0 4.6 5.1	3.4 5.2 5.3 5.4	–	A pk
Ignition Coil Current Peak, Normal RPM Frequency = 33 Hz 133 Hz 200 Hz 267 Hz 333 Hz	$I_o(\text{pk})$	5.1 5.1 4.2 3.4 2.7	5.5 5.5 5.4 4.4 3.4	–	A pk
Ignition Coil On-Time, Normal RPM Range Frequency = 33 Hz 133 Hz 200 Hz 267 Hz 333 Hz	t_{on}	–	7.5 5.0 4.0 3.0 2.3	14.0 5.9 4.6 3.6 2.8	ms
Shutdown Voltage	V_{bat}	25	30	35	Vdc
Input Threshold (Static Test) Turn-on Turn-off	$V_{\text{S2}} - V_{\text{S1}}$	–	360 90	–	mVdc
Input Threshold Hysteresis	$V_{\text{S2}} - V_{\text{S1}}$	75	–	–	mVdc
Input Threshold (Active Operation) Turn-on Turn-off	V_{S2}	–	1.8 1.5	–	Vdc
Total Circuit Lag from t_s (Figure 1) until Ignition Coil Current Falls to 10%		–	60	120	μs
Ignition Coil Current Fall Time (90% to 10%)		–	4.0	–	μs
Saturation Voltage IC Output (Pin 7) ($R_{\text{DRIVE}} = 100 \Omega$) $V_{\text{bat}} = 10$ Vdc 30 Vdc 50 Vdc	$V_{\text{CE(sat)}}$	–	120 280 540	–	mVdc
Current Limit Reference, Pin 8	V_{ref}	120	160	190	mVdc

Figure 2. Ignition Coil Current versus Frequency/Period

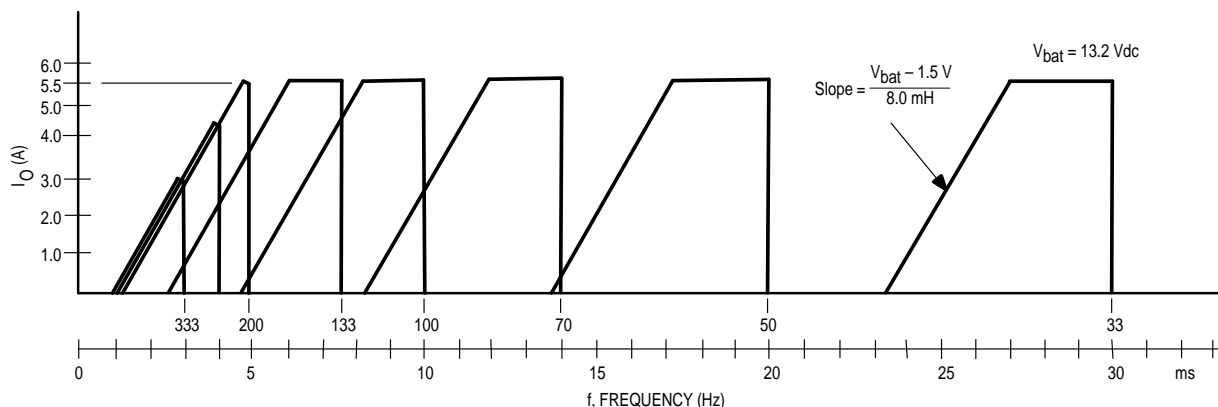

MC3334 MCC3334 MCCF3334

CIRCUIT DESCRIPTION

The MC3334 high energy ignition circuit was designed to serve aftermarket Delco five-terminal ignition applications. This device, driving a high voltage Darlington transistor, offers an ignition system which optimizes spark energy at minimum power dissipation. The IC is pinned-out to permit thick film or printed circuit module design without any crossovers.

The basic function of an ignition circuit is to permit build-up of current in the primary of a spark coil, and then to interrupt the flow at the proper firing time. The resulting flyback action in the ignition coil induces the required high secondary voltage needed for the spark. In the simplest systems, fixed dwell angle produces a fixed duty cycle, which can result in too little stored energy at high RPM, and/or wasted power at low RPM. The MC3334 uses a variable DC voltage reference, stored on C_{Dwell} , and buffered to the bottom end of the reluctor pickup (S1) to vary the duty cycle at the spark coil. At high RPM, the MC3334 holds the output "off" for approximately 1.0 ms to permit full energy discharge from the previous spark; then it switches the output Darlington transistor into full saturation. The current ramps up at a slope dictated by V_{bat} and the coil L. At very high RPM the peak current may be less than desired, but it is limited by the coil itself.

As the RPM decreases, the ignition coil current builds up and would be limited only by series resistance losses. The MC3334 provides adjustable peak current regulation sensed by R_S and set by R_{D1} , in this case at 5.5 A, as shown in Figure 2. As the RPM decreases further, the coil current is held at 5.5 A for a short period. This provides a reserve for sudden acceleration, when discharge may suddenly occur earlier than expected. The peak hold period is about 20% at medium RPM, decreasing to about 10% at very low RPM. (Note: 333 Hz = 5000 RPM for an eight cylinder four stroke engine.) At lower V_{bat} , the "on" period automatically stretches to accommodate the slower current build-up. At very low V_{bat} and low RPM, a common condition during cold starting, the "on" period is nearly the full cycle to permit as much coil current as possible.

The output stage of the IC is designed with an OVP circuit which turns it on at $V_{bat} \approx 30$ V ($V_{CC} \approx 22$ V), holding the output Darlington off. This protects the IC and the Darlington from damage due to load dump or other causes of excessive V_{bat} .

Component Values

- Pickup – series resistance = $800 \Omega \pm 10\%$ @ 25°C
inductance = 1.35 H @ 1.0 kHz @ 15 Vrms
- Coil – leakage L = 0.6 mH
primary R = $0.43 \Omega \pm 5\%$ @ 25°C
primary L = 7.5 mH to 8.5 mH @ 5.0 A
- R_L – load resistor for pickup = $10 \text{ k}\Omega \pm 20\%$
- R_A, R_B – input buffer resistors provide additional transient protection to the already clamped inputs = $20 \text{ k}\Omega \pm 20\%$

- $C1, C2$ – for reduction of high frequency noise and spark transients induced in pick-up and leads; optional and non-critical
- R_{bat} – provides load dump protection (but small enough to allow operation at $V_{bat} = 4.0$ V) = $300 \Omega \pm 20\%$
- C_{Filter} – transient filter on V_{CC} , non-critical
- C_{Dwell} – stores reference, circuit designed for $0.1 \mu\text{F} \pm 20\%$
- R_{Gain} – R_{Gain}/R_{D1} sets the DC gain of the current regulator = $5.0 \text{ k}\Omega \pm 20\%$
- R_{D2} – R_{D2}/R_{D1} set up voltage feedback from R_S
- R_S – sense resistor (PdAg in thick film techniques) = $0.075 \Omega \pm 30\%$
- R_{Drive} – low enough to supply drive to the output Darlington, high enough to keep $V_{CE(sat)}$ of the IC below Darlington turn-on during load dump = $100 \Omega \pm 20\%$, 5.0 W
- R_{D1} – starting with 35Ω assures less than 5.5 A, increasing as required to set 5.5 A

$$R_{D1} = \frac{I_{O(pk)} R_S - V_{ref}}{\frac{V_{ref}}{R_{D2}} - \frac{1.4}{R_{Gain}}} \quad - (\approx 100 \Omega)$$

General Layout Notes

The major concern in the substrate design should be to reduce ground resistance problems. The first area of concern is the metallization resistance in the power ground to module ground and the output to the R_{drive} resistor. This resistance directly adds to the $V_{CE(sat)}$ of the IC power device and if not minimized could cause failure in load dump. The second concern is to reference the sense ground as close to the ground end of the sense resistor as possible in order to further remove the sensitivity of ignition coil current to ground I.R. drops.

All versions were designed to provide the same pin-out order viewed from the top (component side) of the board or substrate. This was done to eliminate conductor cross-overs. The standard MC3334 plastic device is numbered in the industry convention, counter-clockwise viewed from the top, or bonding pad side. The MCCF3334 "flip" or "bump" chip is made from reversed artwork, so it is numbered clockwise viewed from its bump side. Since this chip is mounted face down, the resulting assembly still has the same counter-clockwise order viewed from above the component surface. All chips have the same size and bonding pad spacing. See Figure 4 for dimensions.

MC3334 MCC3334 MCCF3334

Figure 3. Internal Schematic

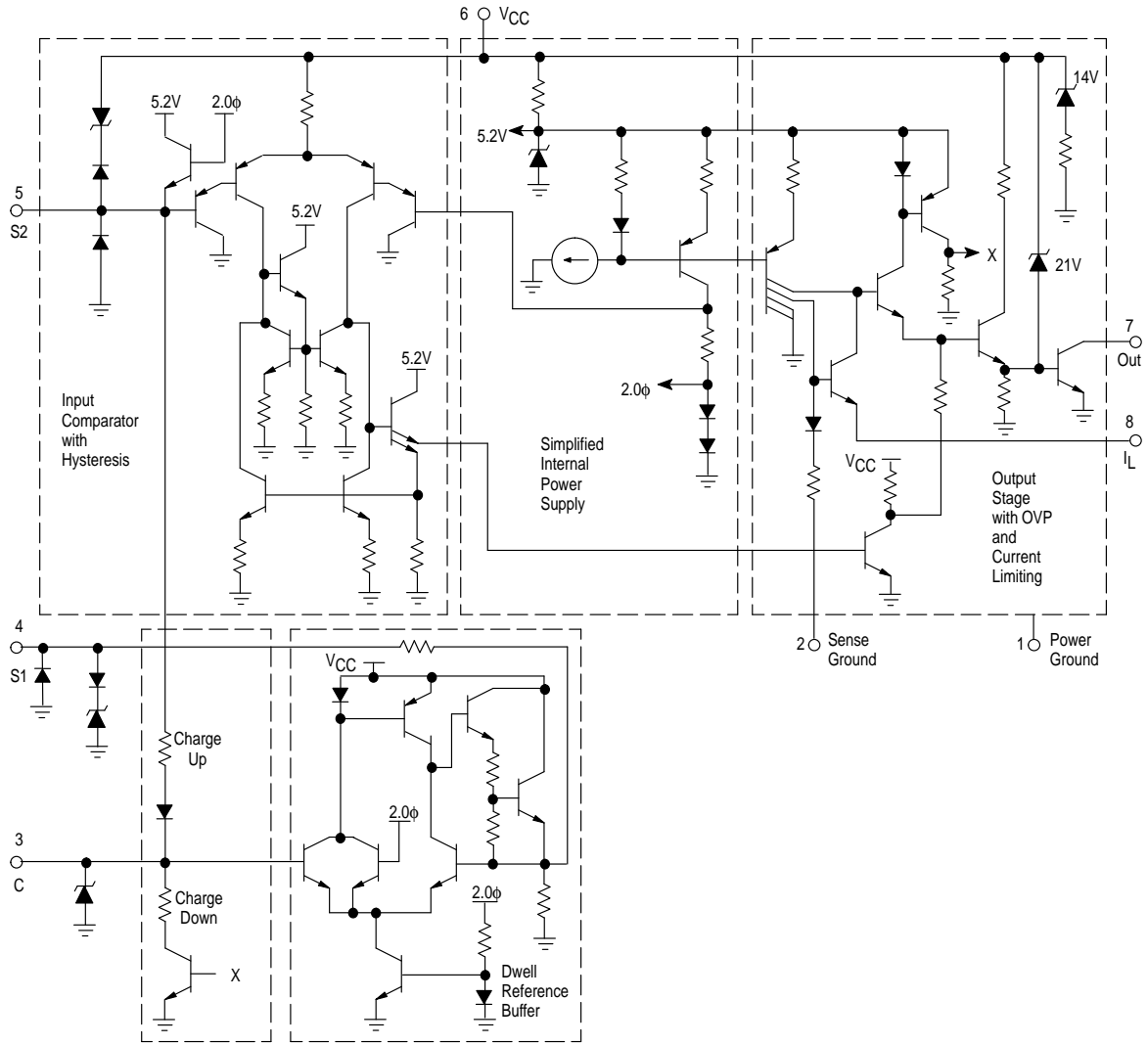
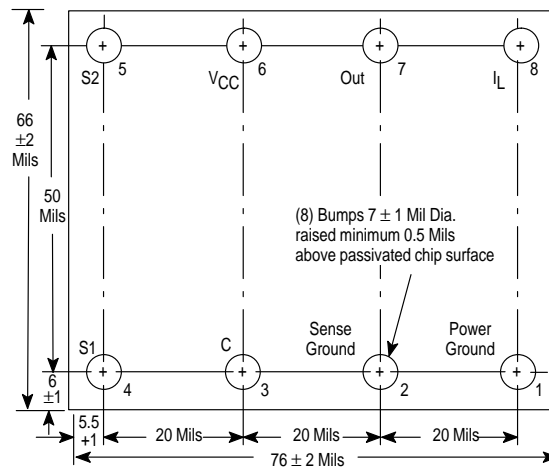

Figure 4. MCCF3334 Ignition Circuit Bump Side View



MC3334 MCC3334 MCCF3334

OUTLINE DIMENSIONS

P SUFFIX
PLASTIC PACKAGE
CASE 626-05
ISSUE K

NOTE 2

SEATING PLANE

⊕ 0.13 (0.005) (M) T A (M) B (M)

NOTES:

- DIMENSION L TO CENTER OF LEAD WHEN FORMED PARALLEL.
- PACKAGE CONTOUR OPTIONAL (ROUND OR SQUARE CORNERS).
- DIMENSIONING AND TOLERANCING PER ANSI Y14.5M, 1982.

DIM	MILLIMETERS		INCHES	
	MIN	MAX	MIN	MAX
A	9.40	10.16	0.370	0.400
B	6.10	6.60	0.240	0.260
C	3.94	4.45	0.155	0.175
D	0.38	0.51	0.015	0.020
F	1.02	1.78	0.040	0.070
G	2.54 BSC		0.100 BSC	
H	0.76	1.27	0.030	0.050
J	0.20	0.30	0.008	0.012
K	2.92	3.43	0.115	0.135
L	7.62 BSC		0.300 BSC	
M	—		10°	
N	0.76	1.01	0.030	0.040

D SUFFIX
PLASTIC PACKAGE
CASE 751-05
(SO-8)
ISSUE N

⊕ 0.25 (0.010) (M) B (M)

NOTES:

- DIMENSIONING AND TOLERANCING PER ANSI Y14.5M, 1982.
- CONTROLLING DIMENSION: MILLIMETER.
- DIMENSIONS A AND B DO NOT INCLUDE MOLD PROTRUSION.
- MAXIMUM MOLD PROTRUSION 0.15 (0.006) PER SIDE.
- DIMENSION D DOES NOT INCLUDE DAMBAR PROTRUSION. ALLOWABLE DAMBAR PROTRUSION SHALL BE 0.127 (0.005) TOTAL IN EXCESS OF THE D DIMENSION AT MAXIMUM MATERIAL CONDITION.

DIM	MILLIMETERS		INCHES	
	MIN	MAX	MIN	MAX
A	4.80	5.00	0.189	0.196
B	3.80	4.00	0.150	0.157
C	1.35	1.75	0.054	0.068
D	0.35	0.49	0.014	0.019
F	0.40	1.25	0.016	0.049
G	1.27 BSC		0.050 BSC	
J	0.18	0.25	0.007	0.009
K	0.10	0.25	0.004	0.009
M	0°		7°	
P	5.80	6.20	0.229	0.244
R	0.25	0.50	0.010	0.019

MC3334 MCC3334 MCCF3334

Motorola reserves the right to make changes without further notice to any products herein. Motorola makes no warranty, representation or guarantee regarding the suitability of its products for any particular purpose, nor does Motorola assume any liability arising out of the application or use of any product or circuit, and specifically disclaims any and all liability, including without limitation consequential or incidental damages. "Typical" parameters which may be provided in Motorola data sheets and/or specifications can and do vary in different applications and actual performance may vary over time. All operating parameters, including "Typicals" must be validated for each customer application by customer's technical experts. Motorola does not convey any license under its patent rights nor the rights of others. Motorola products are not designed, intended, or authorized for use as components in systems intended for surgical implant into the body, or other applications intended to support or sustain life, or for any other application in which the failure of the Motorola product could create a situation where personal injury or death may occur. Should Buyer purchase or use Motorola products for any such unintended or unauthorized application, Buyer shall indemnify and hold Motorola and its officers, employees, subsidiaries, affiliates, and distributors harmless against all claims, costs, damages, and expenses, and reasonable attorney fees arising out of, directly or indirectly, any claim of personal injury or death associated with such unintended or unauthorized use, even if such claim alleges that Motorola was negligent regarding the design or manufacture of the part. Motorola and  registered trademarks of Motorola, Inc. Motorola, Inc. is an Equal Opportunity/Affirmative Action Employer.

How to reach us:

USA/EUROPE/Locations Not Listed: Motorola Literature Distribution;
P.O. Box 20912; Phoenix, Arizona 85036. 1-800-441-2447 or 602-303-5454

MFAX: RMFAX0@email.sps.mot.com – TOUCHTONE 602-244-6609
INTERNET: <http://Design-NET.com>

JAPAN: Nippon Motorola Ltd.; Tatsumi-SPD-JLDC, 6F Seibu-Butsuryu-Center,
3-14-2 Tatsumi Koto-Ku, Tokyo 135, Japan. 03-81-3521-8315

ASIA/PACIFIC: Motorola Semiconductors H.K. Ltd.; 8B Tai Ping Industrial Park,
51 Ting Kok Road, Tai Po, N.T., Hong Kong. 852-26629298



MOTOROLA



MC3334/D

