

MC33466

Advanced Information

Fixed Frequency PWM Micropower DC-to-DC Converter

The MC33466 series are micropower switching voltage regulators, specifically designed for handheld and laptop applications, to provide regulated output voltages using a minimum of external parts. A wide choice of output voltages are available. These devices feature a very low quiescent bias current of 15 μ A typical.

The MC33466H-XXJT1 series features a highly accurate voltage reference, an oscillator, a pulse width modulation (PWM) controller, a driver transistor (Lx), an error amplifier and feedback resistive divider.

The MC33466H-XXLT1 is identical to the MC33466H-XXJT1, except that a drive pin (EXT) for an external transistor is provided.

Due to the low bias current specifications, these devices are ideally suited for battery powered computer, consumer, and industrial equipment where an extension of useful battery life is desirable.

MC33466 Series Features:

- Low Quiescent Bias Current of 15 μ A
- High Output Voltage Accuracy of $\pm 2.5\%$
- Low Startup Voltage of 0.9 V at 1.0 mA
- Soft-Start = 500 μ s
- Surface Mount Package

ORDERING INFORMATION

Device	Output Voltage	Type	Operating Temperature Range	Package (Tape/Reel)
MC33466H-30JT1	3.0	Int.	$T_A = -30^\circ$ to $+80^\circ\text{C}$	SOT-89 (Tape)
MC33466H-33JT1	3.3	Switch		
MC33466H-50JT1	5.0			
MC33466H-30LT1	3.0	Ext.	$T_A = -30^\circ$ to $+80^\circ\text{C}$	SOT-89 (Tape)
MC33466H-33LT1	3.3	Switch		
MC33466H-50LT1	5.0	Drive		

Other voltages from 2.5 V to 7.5 V, in 0.1 V increments are available. Consult factory for information.

FIXED FREQUENCY PWM MICROPOWER DC-to-DC CONVERTER

SEMICONDUCTOR TECHNICAL DATA

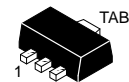

H SUFFIX
PLASTIC PACKAGE
CASE 1213
(SOT-89)

PIN CONNECTIONS

MC33466H-XXJT1

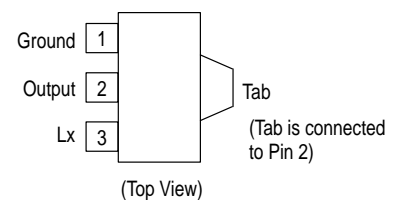

MC33466H-XXLT1

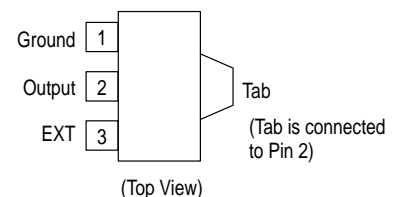

MC33466

Representative Block Diagrams

MC33466H-XXJT1

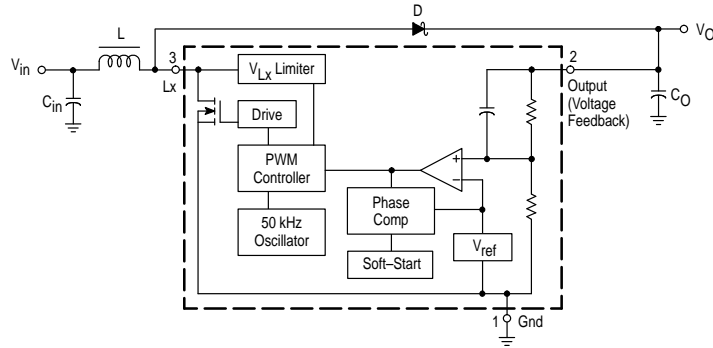

MC33466H-XXLT1

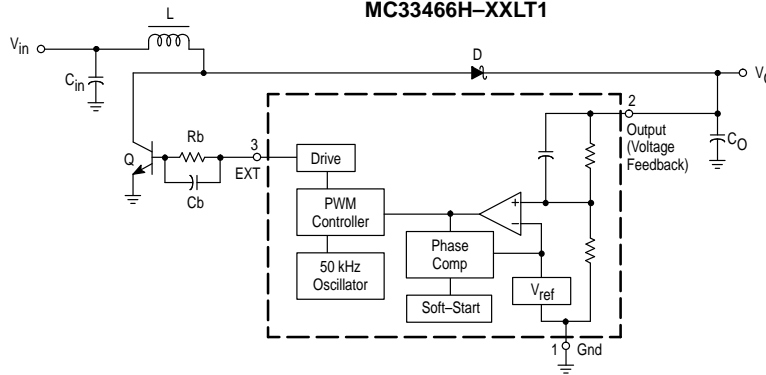

XX Denotes Output Voltage

This device contains 100 active transistors.

MAXIMUM RATINGS (T_C = 25°C, unless otherwise noted.)

Rating	Symbol	Value	Unit
Power Supply Voltage (Transient)	V _O	12	V
Power Supply Voltage (Operating)	V _O	8.0	V
External Pin Voltage	V _{EXT}	-0.3 to V _O	V
Lx Pin Voltage	V _{Lx}	12	V
EXT Pin Source/Sink Current	I _{EXT}	50/50	mA
Lx Pin Sink Current	I _{Lx}	250	mA
Power Dissipation and Thermal Characteristics H Suffix, Plastic Package Case 1213 (SOT-89) Maximum Power Dissipation @ T _A = 25°C Thermal Resistance, Junction-to-Air	P _D R _{θJA}	500 200	mW °C/W
Operating Junction Temperature	T _J	125	°C
Operating Ambient Temperature	T _A	-30 to +80	°C
Storage Temperature Range	T _{stg}	-40 to +125	°C

NOTE: ESD data available upon request.

MC33466

ELECTRICAL CHARACTERISTICS ($V_{CC} = 2.0\text{ V}$, $I_O = 10\text{ mA}$ and $T_A = 25^\circ\text{C}$, unless otherwise noted.)

Characteristic	Symbol	Min	Typ	Max	Unit
OSCILLATOR					
Frequency	f_{osc}	40	50	60	kHz
Oscillator Minimum Startup Voltage ($I_O = 0\text{ mA}$)	V_{start}	–	0.8	0.9	V
Oscillator Minimum Supply Voltage ($I_O = 0\text{ mA}$)	V_{CC}	0.7	–	–	V
LX OUTPUT (JT1 SUFFIX)					
ON State Sink Current ($V_{LX} = 0.4\text{ V}$) 30KT1 Suffix 33KT1 Suffix 50KT1 Suffix	I_{Lx}	60 63 80	– – –	– – –	mA
V_{LX} Voltage Limit (Note 1)	V_{LxLim}	0.65	0.8	1.0	V
OFF State Leakage Current ($V_{LX} = 6.0\text{ V}$)	I_{LKG}	–	–	0.5	μA
EXT OUTPUT (LT1 SUFFIX)					
ON State Source Current ($V_{EXT} = V_O - 0.4\text{ V}$) 30LT1 Suffix 33LT1 Suffix 50LT1 Suffix	I_{source}	1.5 1.575 2.0	– – –	– – –	mA
OFF State Sink Current ($V_{EXT} = 0.4\text{ V}$) 30LT1 Suffix 33LT1 Suffix 50LT1 Suffix	I_{sink}	1.5 1.575 2.0	– – –	– – –	mA
TOTAL DEVICE					
Maximum Duty Ratio Each Cycle	D	70	80	90	%
Output Voltage 30KT1 or 30LT1 Suffix 33KT1 or 33LT1 Suffix 50KT1 or 50LT1 Suffix	V_O	2.925 3.218 4.875	3.0 3.3 5.0	3.075 3.383 5.125	V
Soft–Start Time (Note 2)	T_{SS}	0.5	2.0	–	ms
Quiescent Bias Current ($V_{in} = 2.0\text{ V}$, $I_O = 0\text{ mA}$) 30JT1 Suffix 33JT1 Suffix 50JT1 Suffix	I_Q	– – –	15 17 30	25 27 45	μA
Quiescent Bias Current ($V_{in} = V_O + 0.5\text{ V}$, $I_O = 0\text{ mA}$) 30JT1 Suffix 33JT1 Suffix 50JT1 Suffix	I_Q	– – –	1.2 1.2 2.0	5.0 5.0 5.0	μA
Quiescent Bias Current ($V_{in} = 2.0\text{ V}$, $I_O = 0\text{ mA}$) 30LT1 Suffix 33LT1 Suffix 50LT1 Suffix	I_Q	– – –	30 34.5 60	50 56 90	μA
Quiescent Bias Current ($V_{in} = V_O + 0.5\text{ V}$, $I_O = 0\text{ mA}$) 30LT1 Suffix 33LT1 Suffix 50LT1 Suffix	I_Q	– – –	1.2 1.2 2.0	5.0 5.0 5.0	μA

- NOTES:**
- When the Lx switch is turned on, I_{Lx} current carried through the $R_{DS(on)}$ of the Lx switch results in V_{Lx} . When V_{Lx} reaches V_{LxLim} , the Lx switch is turned off by the Lx switch protection circuit.
 - The soft–start circuit turn–on sequence is as follows:
 - V_{in} is applied.
 - The internal IC V_{ref} is held at zero for 200 μs . During this time, the error amplifier output voltage ramps up to the positive voltage rail.
 - The internal reference steps up to 0.7 V after 200 μs delay has timed out.
 - The error amplifier output voltage integrates down to its steady state value. As the error amplifier output integrates down, the output Lx pin of EXT pin pulse width gradually widens to its steady operating value.

Figure 1. Quiescent Current versus Temperature

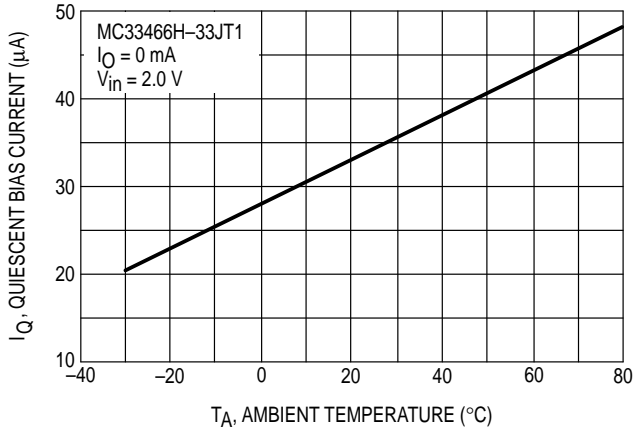

Figure 2. Quiescent Current versus Temperature

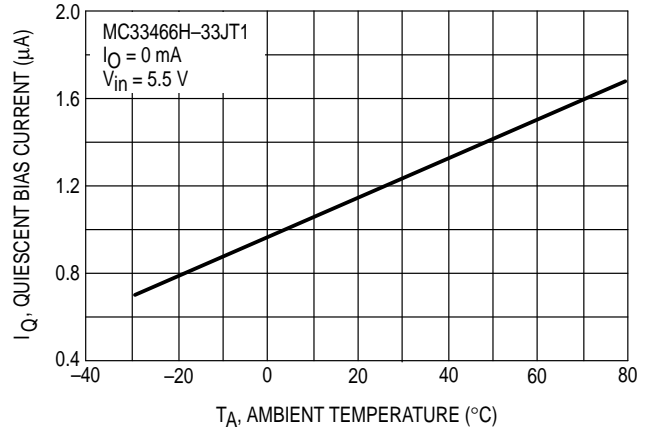

Figure 3. Oscillator Frequency versus Temperature

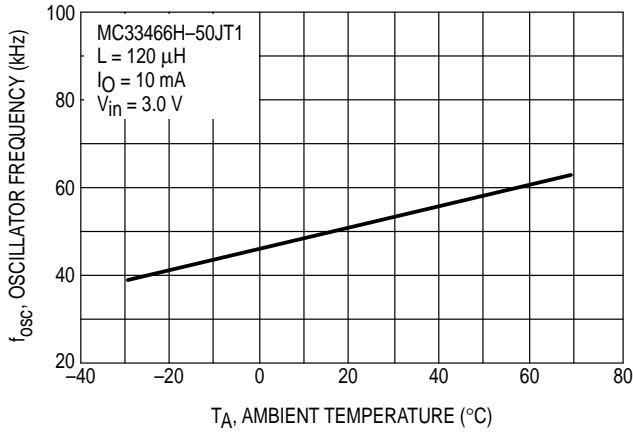

Figure 4. Maximum Duty Ratio versus Temperature

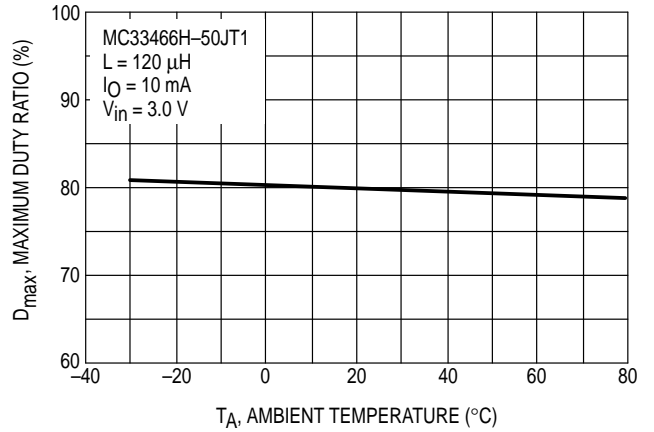

Figure 5. I_{Lx} Switching Current versus Temperature

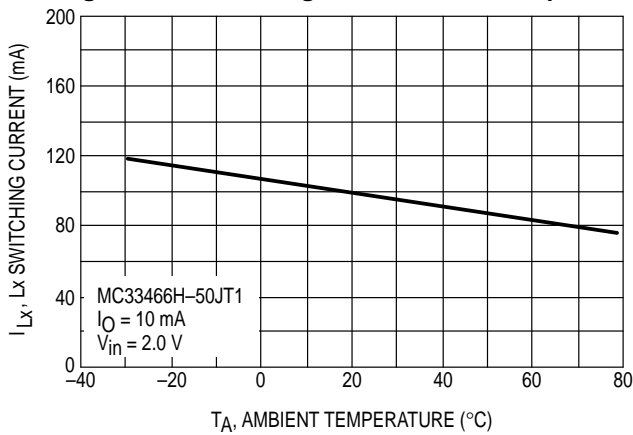

Figure 6. V_{Lx} Voltage Limit versus Temperature

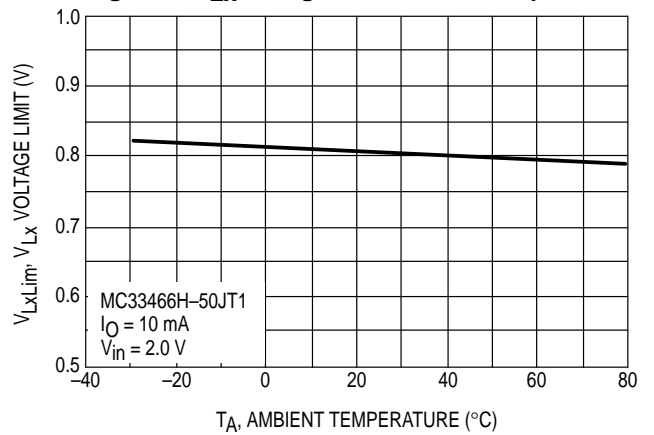

Figure 7. Output Voltage versus Output Current

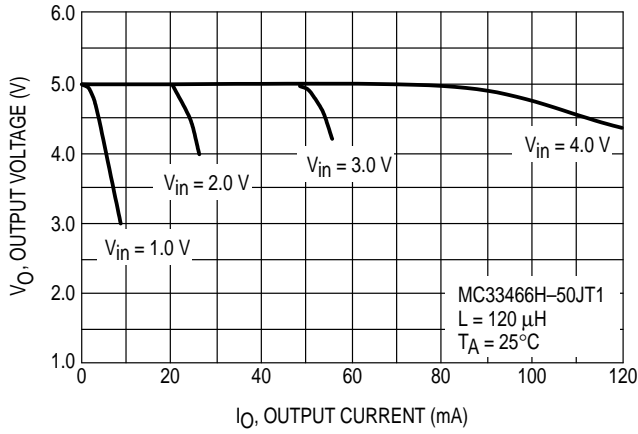

Figure 8. Output Voltage versus Output Current

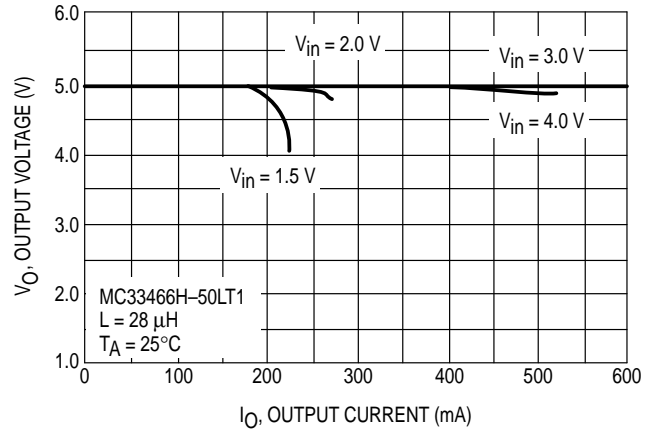

Figure 9. Efficiency versus Output Current

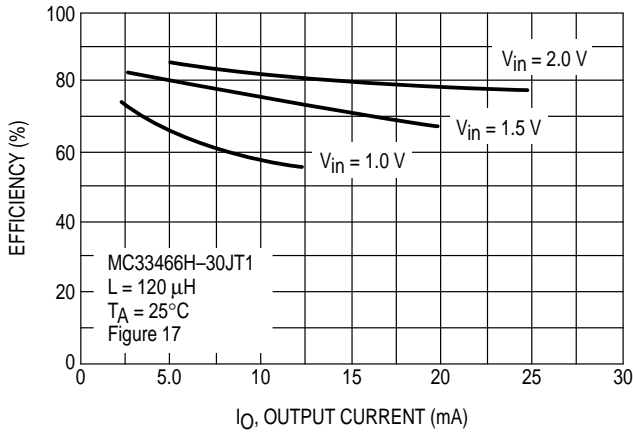

Figure 10. Efficiency versus Output Current

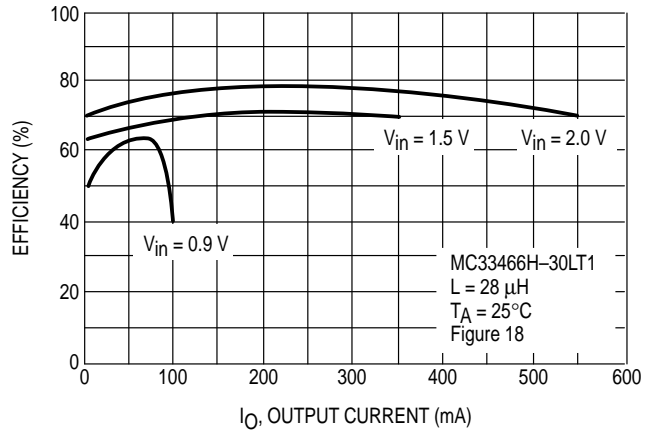

Figure 11. Startup/Hold Voltage versus Output Current

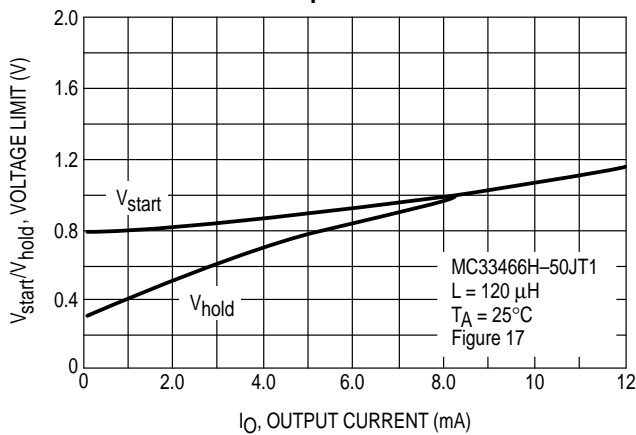

Figure 12. Startup/Hold Voltage versus Output Current

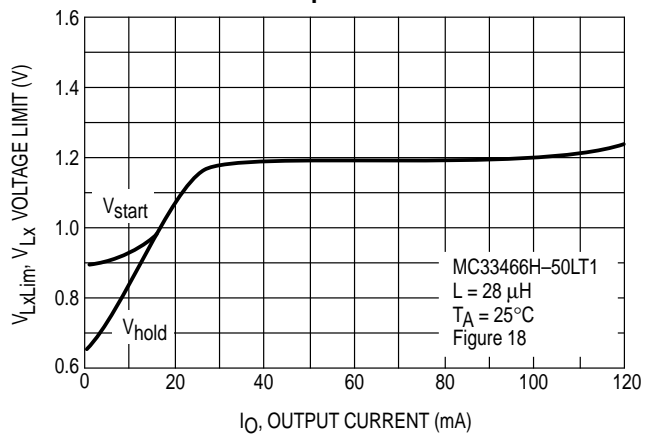

Figure 13. Output Voltage versus Temperature

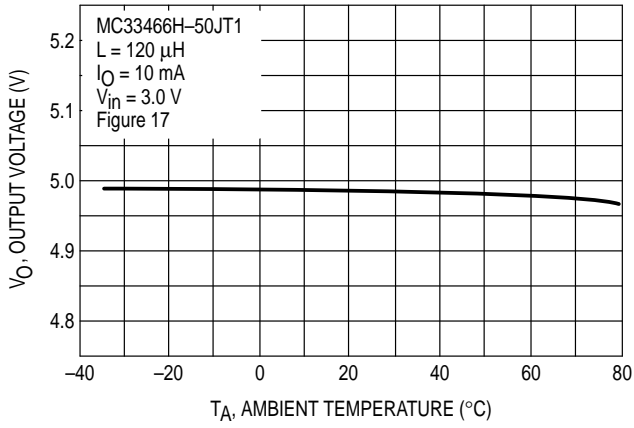

Figure 14. Startup/Hold Voltage versus Temperature

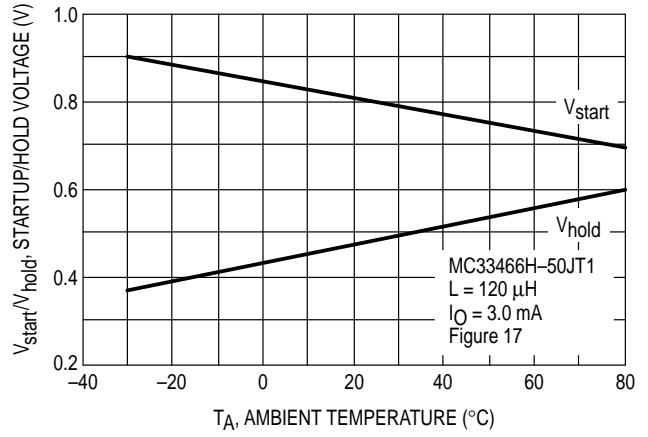

Figure 15. Supply Current versus Input Voltage

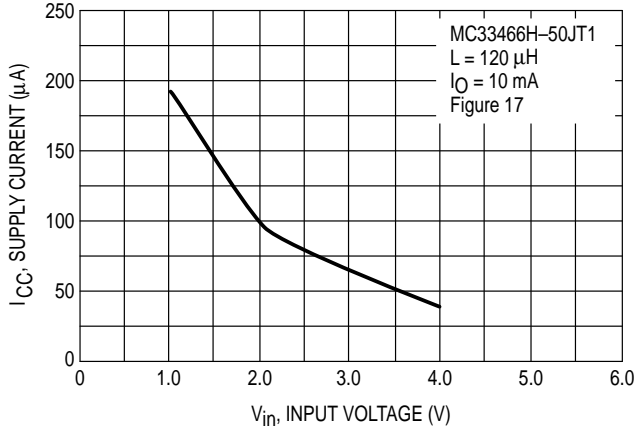
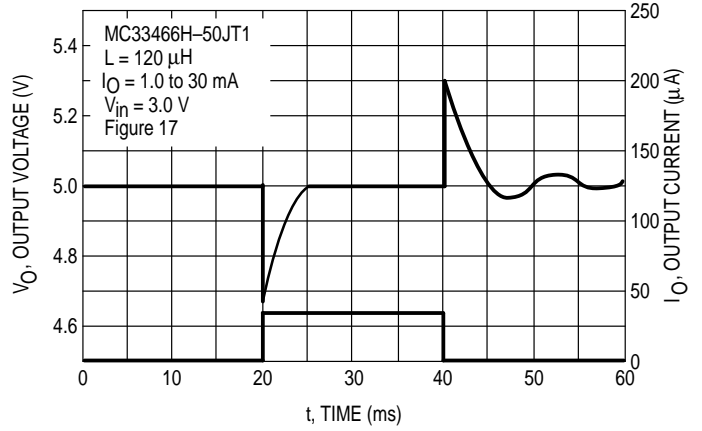

Figure 16. Load Transient Response



DEFINITIONS

Quiescent Bias Current – Current which is used to operate the switching regulator chip and is not delivered to the load.

Leakage Current – Current drawn through a transistor junction, under a specified collector voltage, when the transistor is off.

FUNCTIONAL DESCRIPTION

Introduction

The MC33466 series are monolithic power switching regulators optimized for dc-to-dc converter applications where power drain must be minimized. The combination of features in this series allows the system designer to directly implement step-up, step-down or flyback converters with a small number of external components. Potential applications include low power consumer products and battery powered portable products. Typical application circuits are shown in Figures 17 through 21.

Operating Description

The MC33466 series converters operate as a fixed frequency voltage mode regulator. Operation is intended to be in the discontinuous mode, where the inductor current ramps up to a peak value which is greater than or equal to twice the value of the dc input current during the on-time of the transistor switch. During the off-time of the transistor switch, the inductor current ramps down to zero and remains at zero until another switching cycle begins.

Because the output voltage pin is also used as the supply voltage for powering internal circuitry, an external startup circuit is needed in step-down converter and flyback designs to provide initial power to the integrated circuit to begin switching. The startup circuit needed can be three discrete components, as shown in Figure 19, or a micropower undervoltage sensor, as shown in Figure 20.

Oscillator

The oscillator frequency, is internally programmed to 50 kHz. The timing capacitor (C_T) discharge to charge ratio of the oscillator is designed for a maximum duty cycle of 80% at the Lx or EXT output.

oscillator generates an internal blanking pulse that holds the PWM control off, disabling the output transistor drive. The oscillator peak and valley thresholds are 0.5 V and ground, respectively.

Pulse Width Modulator

The Pulse Width Modulator consists of a comparator with the oscillator ramp voltage applied to the inverting input, while the error amplifier output is applied to the noninverting input. Output switch conduction is initiated when the timing capacitor is charged to its peak voltage value. When the timing capacitor ramp discharges to a voltage below the error amplifier output, the comparator resets a latch terminating output transistor drive for the duration of the oscillator ramp period.

Error Amplifier and Reference

An Error Amplifier is provided which has a nominal 80 dB of voltage gain at dc. Internal compensation components provide poles at 0.25 Hz, 30 kHz and 33 kHz. Two zeros are provided at 1.0 kHz and at 2.5 kHz. The output voltage value is set by the internal voltage divider and a 0.7 V reference which is trimmed to an accuracy of $\pm 2.5\%$. Because the loop compensation components are located within the IC, discontinuous mode operation is recommended for most applications.

Driver and Output Switch

To aid in system design flexibility and conversion efficiency, two output driver options are provided. The MC33466H-XXJT1 converters have an internal drive transistor which is capable of sinking currents greater than 60 mA into the Lx pin. An internal V_{Lx} limiter circuit senses if the Lx pin voltage exceeds 1.0 V during t_{ON} and turns off the drive transistor. The MC33466H-XXJT1 provides output drive for an external transistor.

Applications

The following converter applications show the simplicity and flexibility of the converter architecture. Three main converter topologies are demonstrated in Figures 17 through 21.

Figure 17. MC33466H-50KT1 Typical Step-Up Application

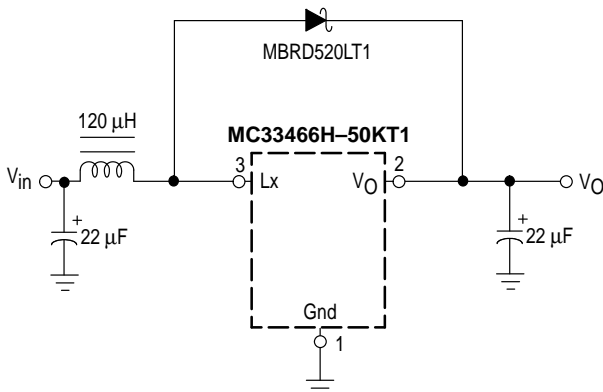
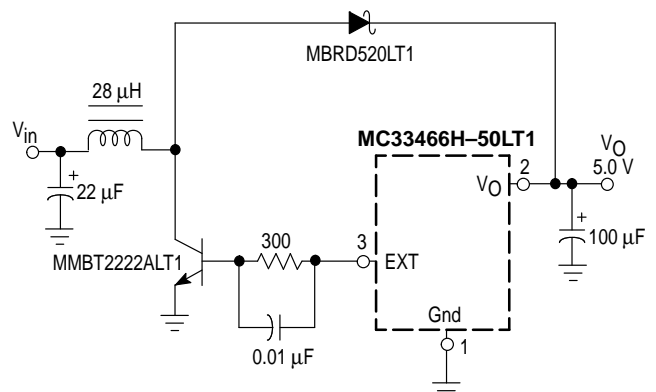
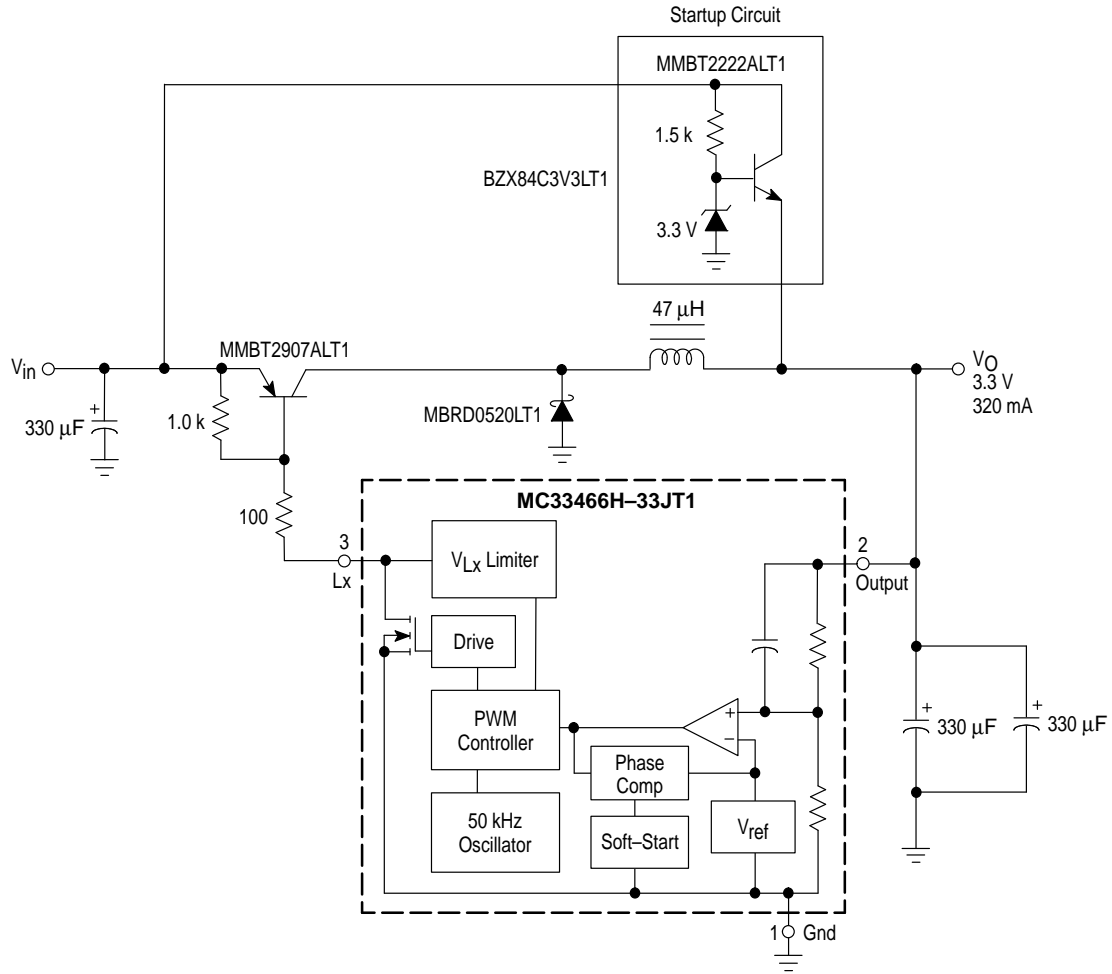

Figure 18. MC33466H-50LT1 Typical Step-Up Application



MC33466

Figure 19. MC33466H-33JT1 Step-Down Application



Test	Condition	Results
Line Regulation	$V_{in} = 5.0 \text{ V to } 10 \text{ V}, I_O = 320 \text{ mA}$	$7 \text{ mV} = \pm 0.1\%$
Load Regulation	$V_{in} = 7.0 \text{ V}, I_O = 3.3 \text{ mA to } 320 \text{ mA}$	$3 \text{ mV} = \pm 0.04\%$
Output Ripple	$V_{in} = 7.0 \text{ V}, I_O = 320 \text{ mA}$	70 mV_{pp}
Efficiency	$V_{in} = 7.0 \text{ V}, I_O = 320 \text{ mA}$	63.8%

MC33466

Figure 20. Micropower Step-Down Application

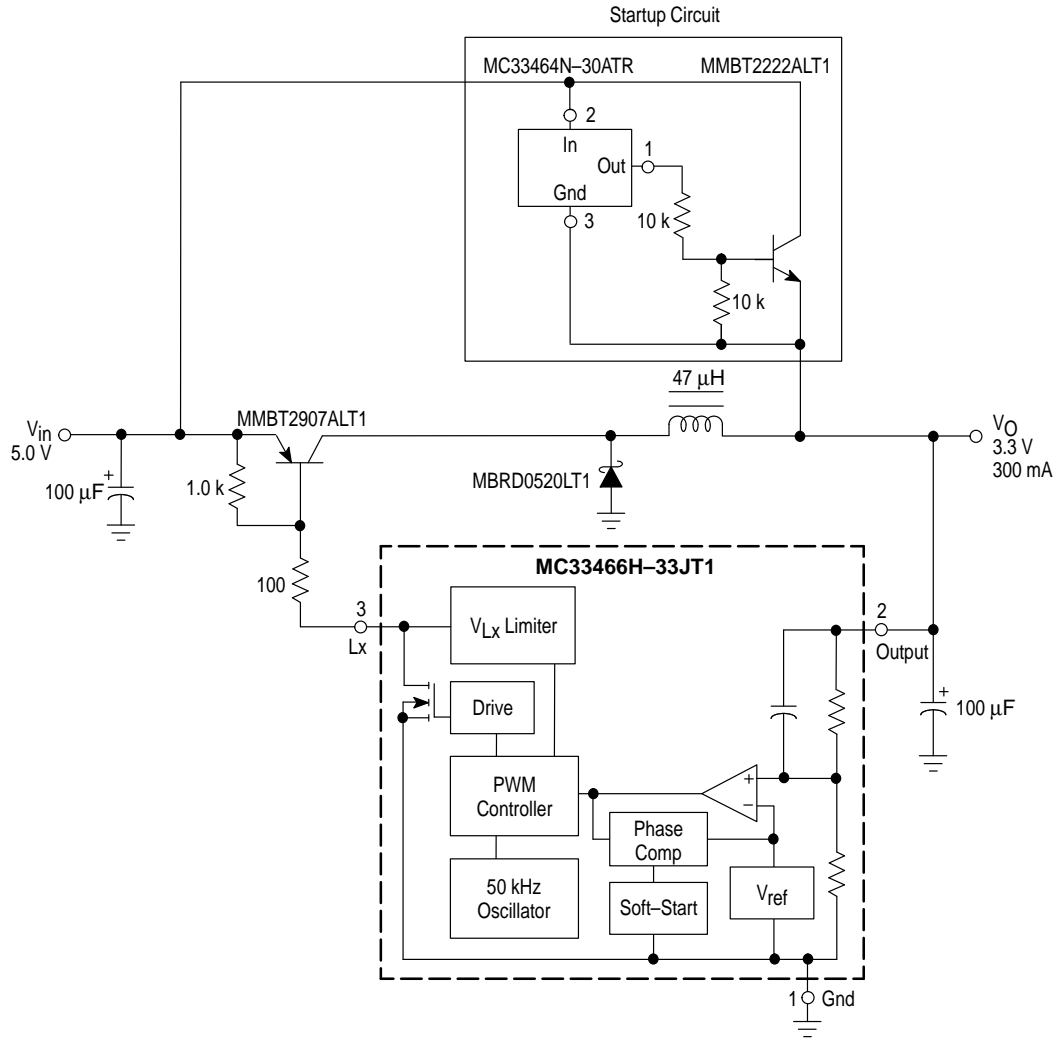

NOTE: Using the MC33464N-30ATR reduces current drawn in the startup circuit to 1 mA during normal operation.

MC33466

Figure 21. Flyback Application

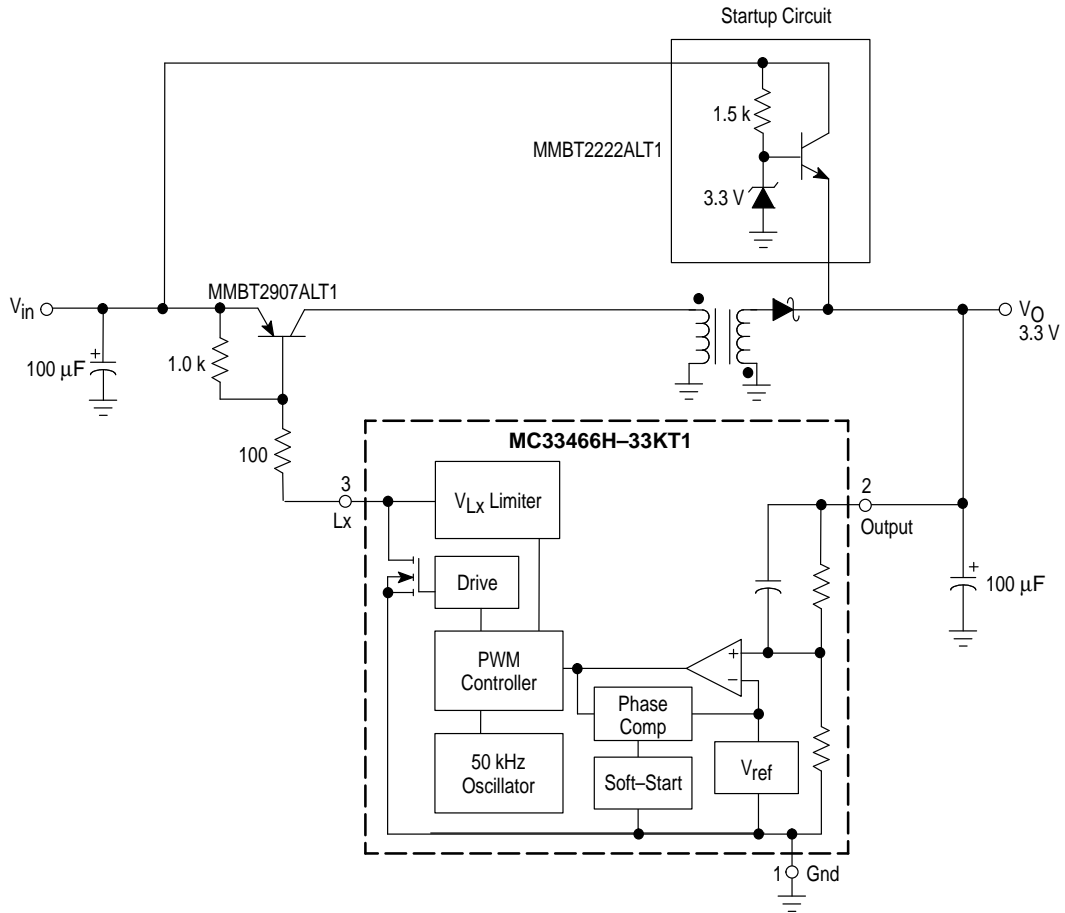

MC33466

Figure 22. Design Equations

Calculation	Step-Down	Step-Up	Flyback
L	$< \frac{(V_{in} - V_O)(t_{on})}{2I_O}$	$< \frac{(V_{in})(t_{on})}{2I_{in}}$	$< \frac{(V_{in})(t_{on})}{2I_{in}}$
t _{on}	$\frac{D}{f_s}$	$\frac{D}{f_s}$	$\frac{D}{f_s}$
D	$< \frac{(V_O)}{(V_{in})}$	$< \frac{(V_O - V_{in})}{(V_O)}$	$< \frac{V_O}{\left[\left(\frac{N_s}{N_p} \right) (V_{in}) + V_O \right]}$
I _L (avg)	I _O	I _{in}	I _{in}
I _L (pk)	$\frac{(V_{in} - V_O)(t_{on})}{L}$	$\frac{(V_{in} - V_{sat})(t_{on})}{L}$	$\frac{(V_{in} - V_{sat})(t_{on})}{L}$
V _{ripple} (pp)	$I_{L(pk)} \left[\left(\frac{1}{8f_s C_O} \right)^2 + (ESR)^2 \right]^{\frac{1}{2}}$		

The following converter design characteristics must be chosen:

V_{in} – Nominal Operating dc input voltage

V_O – Desired dc output voltage

I_O – Desired dc output current

V_{ripple}(pp) – Desired peak-to-peak output ripple voltage. For best performance the ripple voltage should be kept to a low value since it will directly affect line and load regulation. Capacitor C_O should be a low equivalent series resistance (ESR) electrolytic designed for switching regulator applications.

D – Operating duty cycle = t_{on}(fs). This parameter must be chosen to be <0.5 for step-up and flyback applications.

NOTES: 1. V_{sat} – Saturation voltage of the switching transistor.

2. I_{in} – DC input current.

3. f_s – Switching frequency, nominally 50 kHz.

4. R_O – Load resistance. R_O = V_O/I_O.

5. N_s, N_p – In flyback applications N_s is the number of turns of the secondary transformer winding; N_p is the number of the primary winding turns.

Design Example – Step-down Application

Required: V_{in} = 8.0 V, an output voltage of 3.3 V at 300 mA is desired with an output ripple of less than 300 mVpp.

$$R_O = \frac{V_O}{I_O} = 11 \Omega$$

1. Because this is a discontinuous mode design, $D < \frac{V_O}{V_{in}} = \frac{3.3}{8} = 0.41$. Choose D = 0.33.

$$2. t_{on} \approx \frac{D}{f_s} = \frac{0.33}{(50 \text{ kHz})} = 6.6 \mu\text{s}.$$

$$3. L < \frac{(V_{in} - V_O)(t_{on})}{2I_O} = \frac{(8 - 3.3)(6.6 \mu\text{s})}{[2(0.3)]} = 51.7 \mu\text{H}.$$

Choose L = 47 μH. Coilcraft part number DO3316P-473.

$$4. I_{L(pk)} = \frac{(V_{in} - V_O)(t_{on})}{L} = \frac{(8 - 3.3)(6.6 \mu\text{s})}{(47 \mu\text{H})} = 660 \text{ mA}.$$

$$5. ESR < \frac{V_{ripple(pp)}}{I_{L(pk)}} = \frac{(300 \text{ mV})}{(660 \text{ mA})} = 0.455 \Omega.$$

Choose C_O = two parallel AVX 330 μF tantalum chip capacitors. Part Number TAJE337M006.

Specified maximum ESR for each is 0.9 Ω.

The complete design schematic is shown in Figure 19.

MC33466

OUTLINE DIMENSIONS

H SUFFIX
 PLASTIC PACKAGE
 CASE 1213-01
 (SOT-89)
 ISSUE O

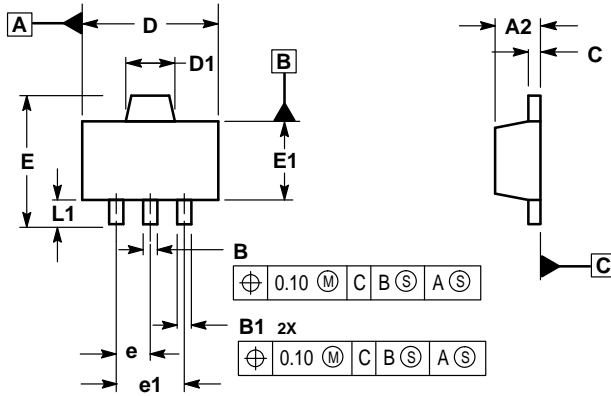

- NOTES:
1. DIMENSIONS ARE IN MILLIMETERS.
 2. INTERPRET DIMENSIONS AND TOLERANCING PER ASME Y14.5M, 1994.
 3. DATUM C IS A SEATING PLANE.

MILLIMETERS		
DIM	MIN	MAX
A2	1.40	1.60
B	0.37	0.57
B1	0.32	0.52
C	0.30	0.50
D	4.40	4.60
D1	1.50	1.70
E	—	4.25
E1	2.40	2.60
e	1.50	BSC
e1	3.00	BSC
L1	0.80	—

Motorola reserves the right to make changes without further notice to any products herein. Motorola makes no warranty, representation or guarantee regarding the suitability of its products for any particular purpose, nor does Motorola assume any liability arising out of the application or use of any product or circuit, and specifically disclaims any and all liability, including without limitation consequential or incidental damages. "Typical" parameters which may be provided in Motorola data sheets and/or specifications can and do vary in different applications and actual performance may vary over time. All operating parameters, including "Typicals" must be validated for each customer application by customer's technical experts. Motorola does not convey any license under its patent rights nor the rights of others. Motorola products are not designed, intended, or authorized for use as components in systems intended for surgical implant into the body, or other applications intended to support or sustain life, or for any other application in which the failure of the Motorola product could create a situation where personal injury or death may occur. Should Buyer purchase or use Motorola products for any such unintended or unauthorized application, Buyer shall indemnify and hold Motorola and its officers, employees, subsidiaries, affiliates, and distributors harmless against all claims, costs, damages, and expenses, and reasonable attorney fees arising out of, directly or indirectly, any claim of personal injury or death associated with such unintended or unauthorized use, even if such claim alleges that Motorola was negligent regarding the design or manufacture of the part. Motorola and are registered trademarks of Motorola, Inc. Motorola, Inc. is an Equal Opportunity/Affirmative Action Employer.

Mfax is a trademark of Motorola, Inc.

How to reach us:

USA/EUROPE/Locations Not Listed: Motorola Literature Distribution;
 P.O. Box 5405, Denver, Colorado 80217. 303-675-2140 or 1-800-441-2447

JAPAN: Nippon Motorola Ltd.: SPD, Strategic Planning Office, 4-32-1,
 Nishi-Gotanda, Shinagawa-ku, Tokyo 141, Japan. 81-3-5487-8488

Mfax™: RMFAX0@email.sps.mot.com – TOUCHTONE 602-244-6609
 – US & Canada ONLY 1-800-774-1848

ASIA/PACIFIC: Motorola Semiconductors H.K. Ltd.; 8B Tai Ping Industrial Park,
 51 Ting Kok Road, Tai Po, N.T., Hong Kong. 852-26629298

INTERNET: <http://motorola.com/sps>

