



MOTOROLA

Order this document by MC34001/D

MC34001, B MC34002, B MC34004, B

JFET Input Operational Amplifiers

These low cost JFET input operational amplifiers combine two state-of-the-art analog technologies on a single monolithic integrated circuit. Each internally compensated operational amplifier has well matched high voltage JFET input devices for low input offset voltage. The BIFET technology provides wide bandwidths and fast slew rates with low input bias currents, input offset currents, and supply currents.

The Motorola BIFET family offers single, dual and quad operational amplifiers which are pin-compatible with the industry standard MC1741, MC1458, and the MC3403/LM324 bipolar devices. The MC34001/34002/34004 series are specified from 0° to +70°C.

- Input Offset Voltage Options of 5.0 mV and 10 mV Maximum
- Low Input Bias Current: 40 pA
- Low Input Offset Current: 10 pA
- Wide Gain Bandwidth: 4.0 MHz
- High Slew Rate: 13 V/μs
- Low Supply Current: 1.4 mA per Amplifier
- High Input Impedance: 10¹² Ω
- High Common Mode and Supply Voltage Rejection Ratios: 100 dB
- Industry Standard Pinouts

JFET INPUT OPERATIONAL AMPLIFIERS

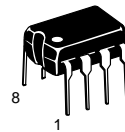

P SUFFIX
PLASTIC PACKAGE
CASE 626



D SUFFIX
PLASTIC PACKAGE
CASE 751
(SO-8)

PIN CONNECTIONS

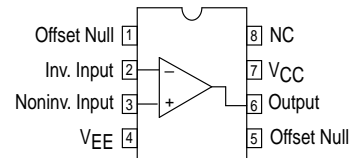

MC34001 (Top View)

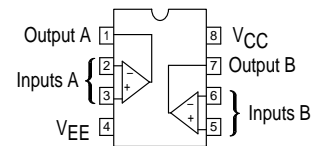

MC34002 (Top View)

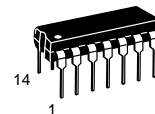

P SUFFIX
PLASTIC PACKAGE
CASE 646

PIN CONNECTIONS

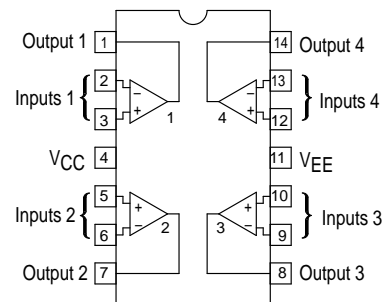

MC34004 (Top View)

ORDERING INFORMATION

Op Amp Function	Device	Operating Temperature Range	Package
Single	MC34001BD, D	T _A = 0° to +70°C	SO-8
	MC34001BP, P		Plastic DIP
Dual	MC34002BD, D	T _A = 0° to +70°C	SO-8
	MC34002BP, P		Plastic DIP
Quad	MC34004BP, P	T _A = 0° to +70°C	Plastic DIP

MC34001, B MC34002, B MC34004, B

MAXIMUM RATINGS

Rating	Symbol	Value	Unit
Supply Voltage	V_{CC}, V_{EE}	± 18	V
Differential Input Voltage (Note 1)	V_{ID}	± 30	V
Input Voltage Range	V_{IDR}	± 16	V
Open Short Circuit Duration	t_{SC}	Continuous	
Operating Ambient Temperature Range	T_A	0 to +70	$^{\circ}\text{C}$
Operating Junction Temperature	T_J	150	$^{\circ}\text{C}$
Storage Temperature Range	T_{stg}	-65 to +150	$^{\circ}\text{C}$

NOTES: 1. Unless otherwise specified, the absolute maximum negative input voltage is equal to the negative power supply.

ELECTRICAL CHARACTERISTICS ($V_{CC} = +15\text{ V}$, $V_{EE} = -15\text{ V}$, $T_A = 25^{\circ}\text{C}$, unless otherwise noted.)

Characteristics	Symbol	Min	Typ	Max	Unit
Input Offset Voltage ($R_S \leq 10\text{ k}$) MC3400XB MC3400X	V_{IO}	— —	3.0 5.0	5.0 10	mV
Average Temperature Coefficient of Input Offset Voltage $R_S \leq 10\text{ k}$, $T_A = T_{low}$ to T_{high} (Note 2)	$\Delta V_{IO}/\Delta T$	—	10	—	$\mu\text{V}/^{\circ}\text{C}$
Input Offset Current ($V_{CM} = 0$) (Note 3) MC3400XB MC3400X	I_{IO}	— —	25 25	100 100	pA
Input Bias Current ($V_{CM} = 0$) (Note 3) MC3400XB MC3400X	I_{IB}	— —	50 50	200 200	pA
Input Resistance	r_i	—	10^{12}	—	Ω
Common Mode Input Voltage Range	V_{ICR}	± 11 —	+15 -12	— —	V
Large Signal Voltage Gain ($V_O = \pm 10\text{ V}$, $R_L = 2.0\text{ k}$) MC3400XB MC3400X	A_{VOL}	50 25	150 100	— —	V/mV
Output Voltage Swing ($R_L \geq 10\text{ k}$) ($R_L \geq 2.0\text{ k}$)	V_O	± 12 ± 10	± 14 ± 13	— —	V
Common Mode Rejection Ratio ($R_S \leq 10\text{ k}$) MC3400XB MC3400X	CMRR	80 70	100 100	— —	dB
Supply Voltage Rejection Ratio ($R_S \leq 10\text{ k}$) (Note 4) MC3400XB MC3400X	PSRR	80 70	100 100	— —	dB
Supply Current (Each Amplifier) MC3400XB MC3400X	I_D	— —	1.4 1.4	2.5 2.7	mA
Slew Rate ($A_V = 1.0$)	SR	—	13	—	$\text{V}/\mu\text{s}$
Gain-Bandwidth Product	GBW	—	4.0	—	MHz
Equivalent Input Noise Voltage ($R_S = 100\ \Omega$, $f = 1000\text{ Hz}$)	e_n	—	25	—	$\text{nV}/\sqrt{\text{Hz}}$
Equivalent Input Noise Current ($f = 1000\text{ Hz}$)	i_n	—	0.01	—	$\text{pA}/\sqrt{\text{Hz}}$

NOTES: 2. $T_{low} = 0^{\circ}\text{C}$ for MC34001/34001B
MC34002
MC34004/34004B
 $T_{high} = +70^{\circ}\text{C}$ for MC34001/34001B
MC34002
MC34004/34004B

3. The input bias currents approximately double for every 10°C rise in junction temperature, T_J . Due to limited test time, the input bias currents are correlated to junction temperature. Use of a heatsink is recommended if input bias current is to be kept to a minimum.

4. Supply voltage rejection ratio is measured for both supply magnitudes increasing or decreasing simultaneously, in accordance with common practice.

MC34001, B MC34002, B MC34004, B

ELECTRICAL CHARACTERISTICS ($V_{CC} = +15\text{ V}$, $V_{EE} = -15\text{ V}$, $T_A = T_{low}$ to T_{high} [Note 2].)

Characteristics	Symbol	Min	Typ	Max	Unit
Input Offset Voltage ($R_S \leq 10\text{ k}$) MC3400XB MC3400X	V_{IO}	— —	— —	7.0 13	mV
Input Offset Current ($V_{CM} = 0$) (Note 3) MC3400XB MC3400X	I_{IO}	— —	— —	4.0 4.0	nA
Input Bias Current ($V_{CM} = 0$) (Note 3) MC3400XB MC3400X	I_{IB}	— —	— —	8.0 8.0	nA
Common Mode Input Voltage Range	V_{ICR}	± 11	—	—	V
Large Signal ($V_O = \pm 10\text{ V}$, $R_L = 2.0\text{ k}$) MC3400XB MC3400X	A_{VOL}	25 15	— —	— —	V/mV
Output Voltage Swing ($R \geq 10\text{ k}$) ($R \geq 2.0\text{ k}$)	V_O	± 12 ± 10	— —	— —	V
Common Mode Rejection Ratio ($R_S \leq 10\text{ k}$) MC3400XB MC3400X	CMRR	80 70	— —	— —	dB
Supply Voltage Rejection Ratio ($R_S \leq 10\text{ k}$) (Note 4) MC3400XB MC3400X	PSRR	80 70	— —	— —	dB
Supply Current (Each Amplifier) MC3400XB MC3400X	I_D	— —	— —	2.8 3.0	mA

NOTES: 2. $T_{low} = 0^\circ\text{C}$ for MC34001/34001B
 MC34002
 MC34004/34004B
 $T_{high} = +70^\circ\text{C}$ for MC34001/34001B
 MC34002
 MC34004/34004B

3. The input bias currents approximately double for every 10°C rise in junction temperature, T_J . Due to limited test time, the input bias currents are correlated to junction temperature. Use of a heatsink is recommended if input bias current is to be kept to a minimum.

4. Supply voltage rejection ratio is measured for both supply magnitudes increasing or decreasing simultaneously, in accordance with common practice.

MC34001, B MC34002, B MC34004, B

Figure 1. Input Bias Current versus Temperature

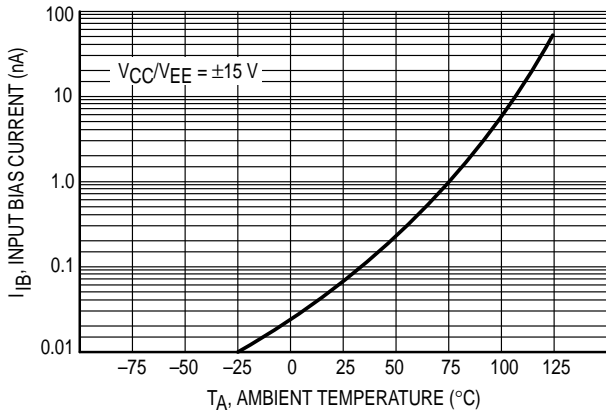

Figure 2. Output Voltage Swing versus Frequency

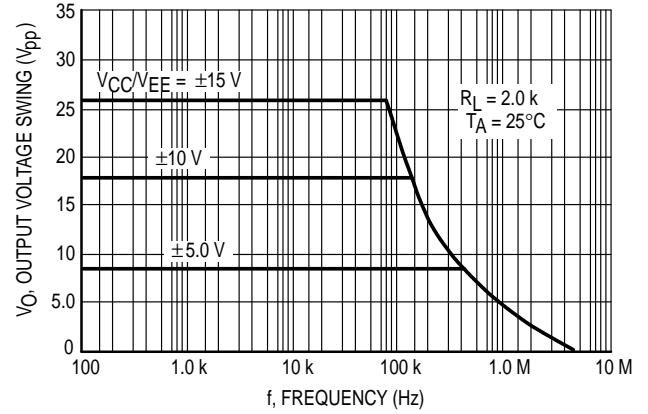

Figure 3. Output Voltage Swing versus Load Resistance

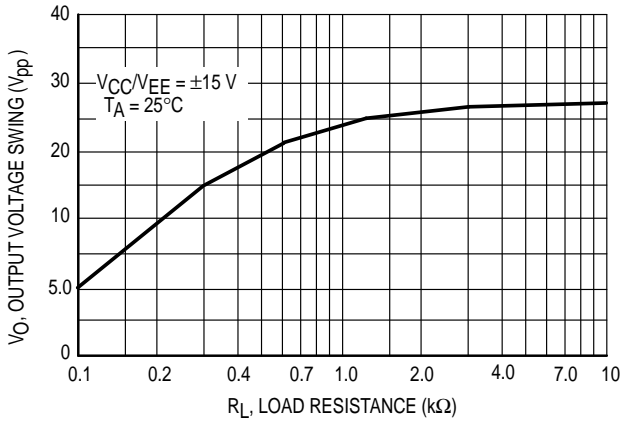

Figure 4. Output Voltage Swing versus Supply Voltage

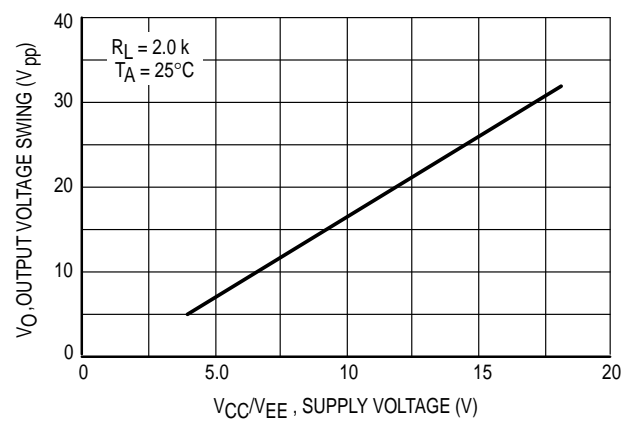

Figure 5. Output Voltage Swing versus Temperature

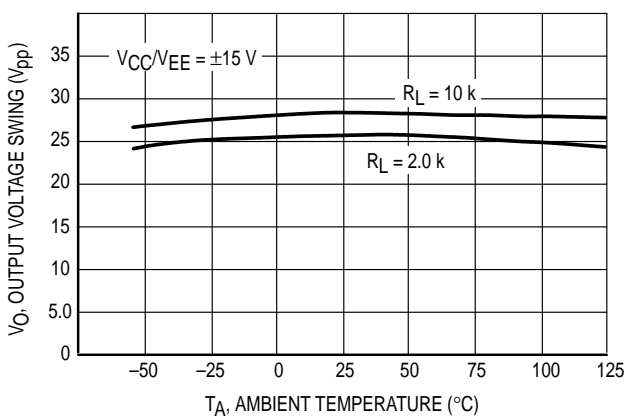
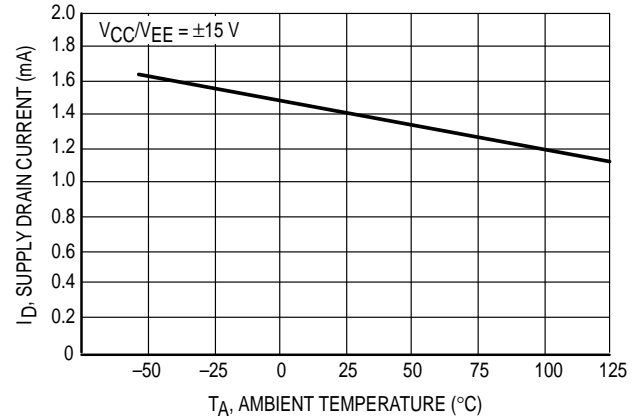

Figure 6. Supply Current per Amplifier versus Temperature



MC34001, B MC34002, B MC34004, B

Figure 7. Large-Signal Voltage Gain and Phase Shift versus Frequency

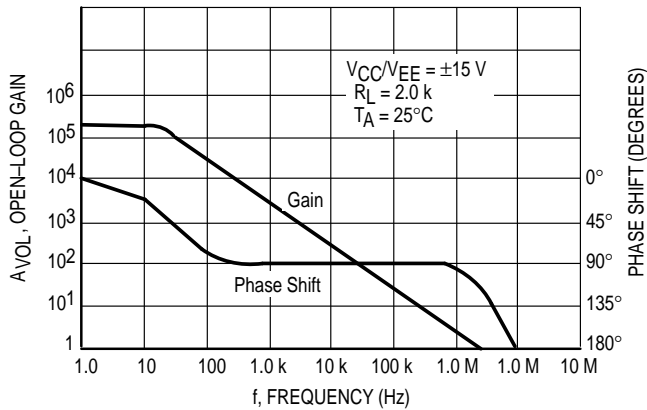

Figure 8. Large-Signal Voltage Gain versus Temperature

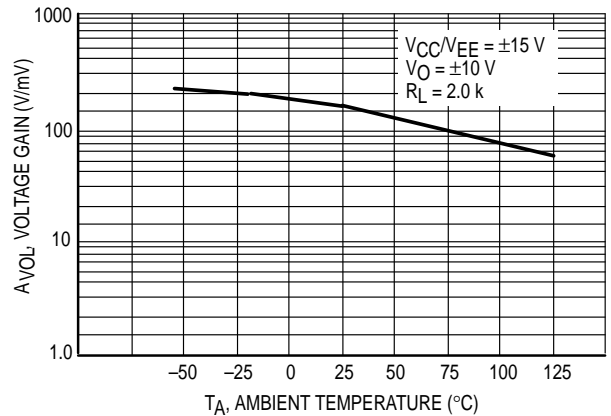

Figure 9. Normalized Slew Rate versus Temperature

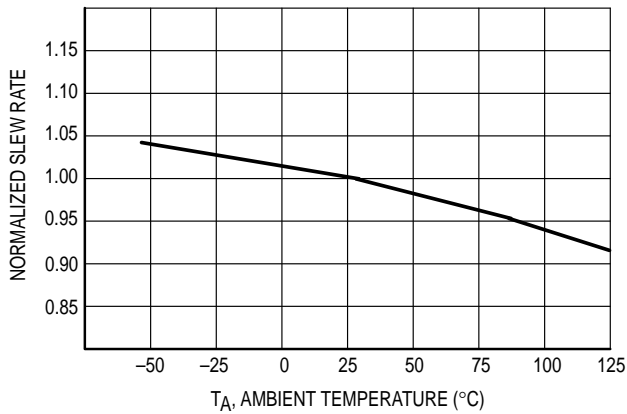

Figure 10. Equivalent Input Noise Voltage versus Frequency

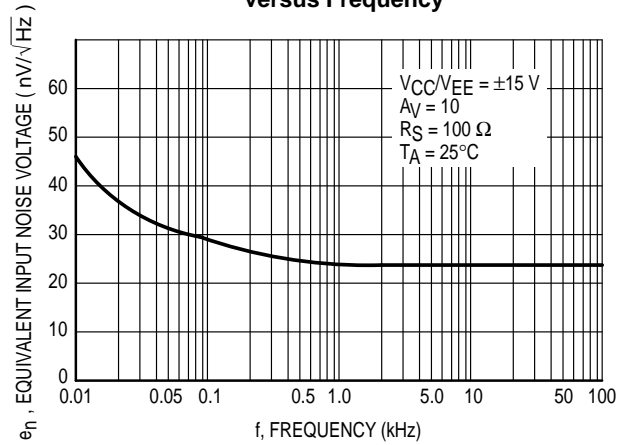
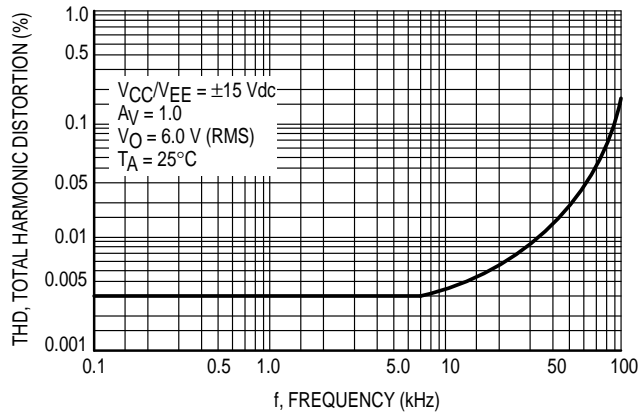

Figure 11. Total Harmonic Distortion versus Frequency



MC34001, B MC34002, B MC34004, B

Representative Circuit Schematic (Each Amplifier)

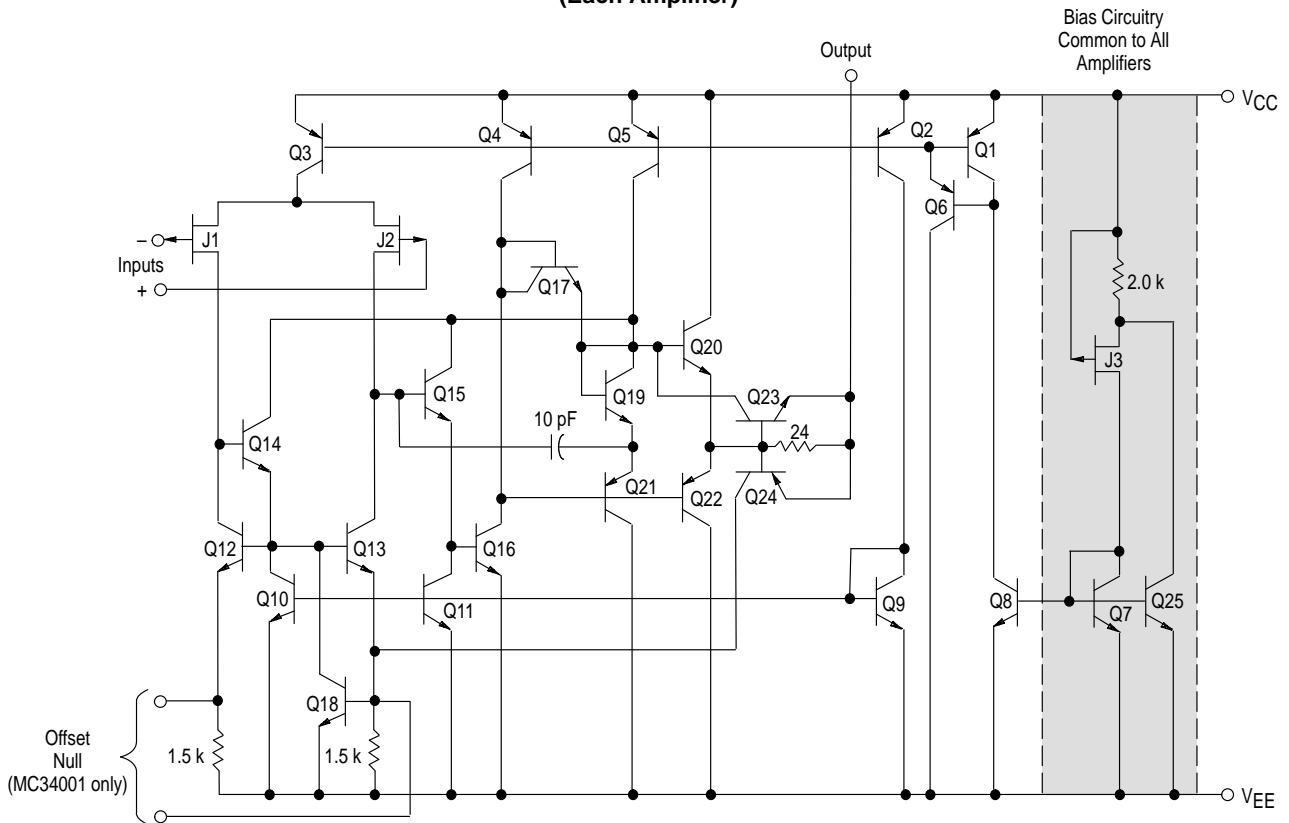
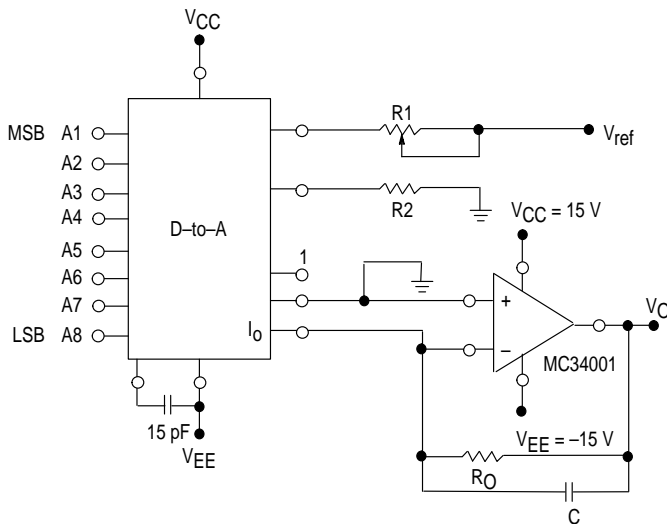

Figure 12. Output Current to Voltage Transformation for a D-to-A Converter



Settling time to within 1/2 LSB is approximately 4.0 μ s from the time all bits are switched ($C = 68$ pF).

The value of C may be selected to minimize overshoot and ringing.

Theoretical V_O

$$V_O = \frac{V_{ref}}{R_1} (R_O) \left[\frac{A_1}{2} + \frac{A_2}{4} + \frac{A_3}{8} + \frac{A_4}{16} + \frac{A_5}{32} + \frac{A_6}{64} + \frac{A_7}{128} + \frac{A_8}{256} \right]$$

MC34001, B MC34002, B MC34004, B

Figure 13. Positive Peak Detector

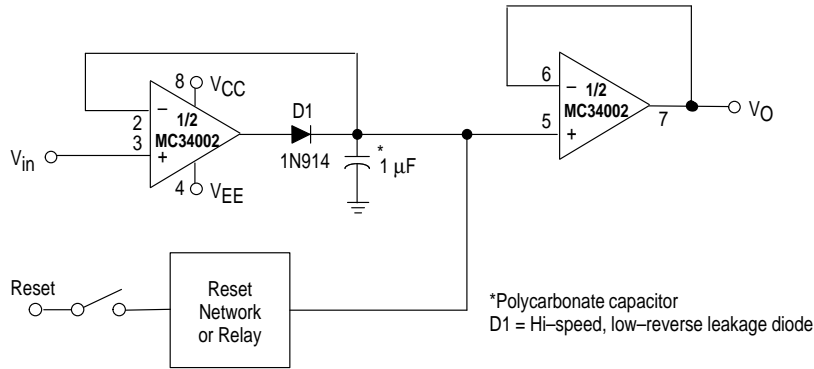
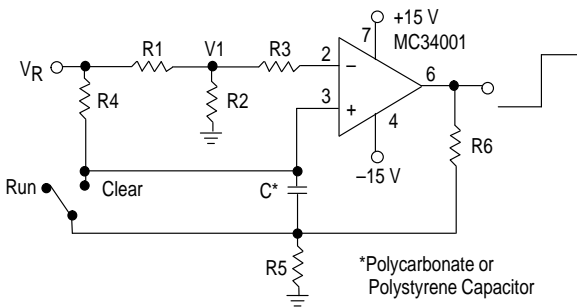

Figure 14. Long Interval RC Timer



Time (t) = R4 Cn (VR/VR-VI), R3 = R4, R5 = 0.1 R6
 If R1 = R2: t = 0.693 R4C

Design Example: 100 Second Timer
 VR = 10 V C = 1.0 µF R3 = R4 = 144 M
 R6 = 20 k R5 = 2.0 k R1 = R2 = 1.0 k

Figure 15. Isolating Large Capacitive Loads

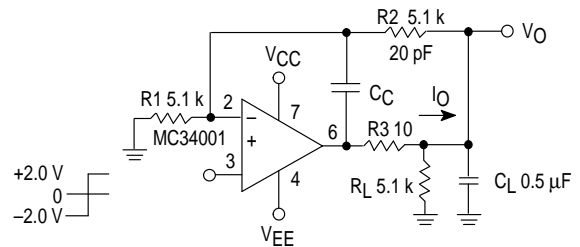

Overshoot < 10%
 ts = 10 µs
 When driving large CL, the VO slew rate is determined by CL and IO(max):

$$\frac{\Delta V_O}{\Delta t} = \frac{I_O}{C_L} = \frac{0.02}{0.5} \text{ V}/\mu\text{s} = 0.04 \text{ V}/\mu\text{s} \text{ (with } C_L \text{ shown)}$$

Figure 16. Wide BW, Low Noise, Low Drift Amplifier

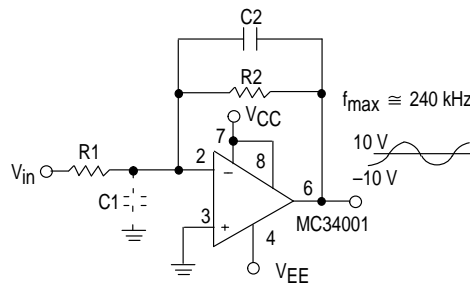

$$\text{Power BW: } f_{\max} = \frac{S_r}{2\pi V_p} \cong 240 \text{ kHz}$$

Parasitic input capacitance (C1 ≅ 3.0 pF plus any additional layout capacitance) interacts with feedback elements and creates undesirable high-frequency pole. To compensate add C2 such that: R2C2 ≅ R1C1.

MC34001, B MC34002, B MC34004, B

OUTLINE DIMENSIONS

P SUFFIX
PLASTIC PACKAGE
 CASE 626-05
 ISSUE K

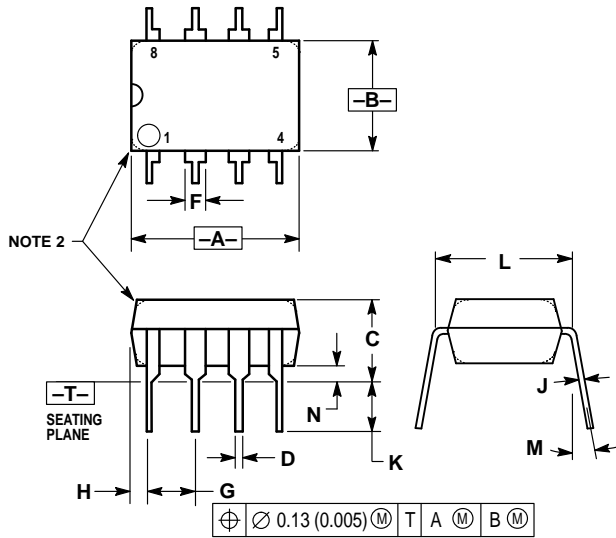

NOTES:

1. DIMENSION L TO CENTER OF LEAD WHEN FORMED PARALLEL.
2. PACKAGE CONTOUR OPTIONAL (ROUND OR SQUARE CORNERS).
3. DIMENSIONING AND TOLERANCING PER ANSI Y14.5M, 1982.

DIM	MILLIMETERS		INCHES	
	MIN	MAX	MIN	MAX
A	9.40	10.16	0.370	0.400
B	6.10	6.60	0.240	0.260
C	3.94	4.45	0.155	0.175
D	0.38	0.51	0.015	0.020
F	1.02	1.78	0.040	0.070
G	2.54 BSC		0.100 BSC	
H	0.76	1.27	0.030	0.050
J	0.20	0.30	0.008	0.012
K	2.92	3.43	0.115	0.135
L	7.62 BSC		0.300 BSC	
M	— 10°		— 10°	
N	0.76	1.01	0.030	0.040

D SUFFIX
PLASTIC PACKAGE
 CASE 751-05
 (SO-8)
 ISSUE R

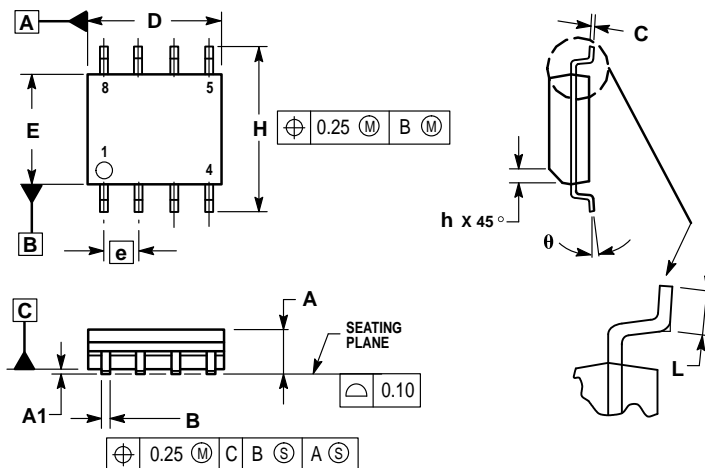

NOTES:

1. DIMENSIONING AND TOLERANCING PER ASME Y14.5M, 1994.
2. DIMENSIONS ARE IN MILLIMETERS.
3. DIMENSION D AND E DO NOT INCLUDE MOLD PROTRUSION.
4. MAXIMUM MOLD PROTRUSION 0.15 PER SIDE.
5. DIMENSION B DOES NOT INCLUDE MOLD PROTRUSION. ALLOWABLE DAMBAR PROTRUSION SHALL BE 0.127 TOTAL IN EXCESS OF THE B DIMENSION AT MAXIMUM MATERIAL CONDITION.

DIM	MILLIMETERS	
	MIN	MAX
A	1.35	1.75
A1	0.10	0.25
B	0.35	0.49
C	0.18	0.25
D	4.80	5.00
E	3.80	4.00
e	1.27 BSC	
H	5.80	6.20
h	0.25	0.50
L	0.40	1.25
θ	0° 7°	

MC34001, B MC34002, B MC34004, B

OUTLINE DIMENSIONS

P SUFFIX
PLASTIC PACKAGE
CASE 646-06
ISSUE L

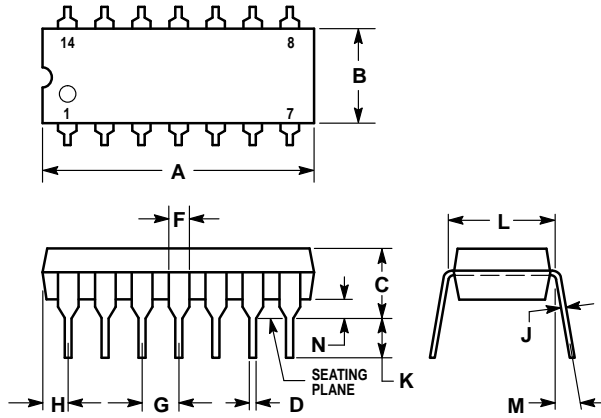

NOTES:

- LEADS WITHIN 0.13 (0.005) RADIUS OF TRUE POSITION AT SEATING PLANE AT MAXIMUM MATERIAL CONDITION.
- DIMENSION L TO CENTER OF LEADS WHEN FORMED PARALLEL.
- DIMENSION B DOES NOT INCLUDE MOLD FLASH.
- ROUNDED CORNERS OPTIONAL.

DIM	INCHES		MILLIMETERS	
	MIN	MAX	MIN	MAX
A	0.715	0.770	18.16	19.56
B	0.240	0.260	6.10	6.60
C	0.145	0.185	3.69	4.69
D	0.015	0.021	0.38	0.53
F	0.040	0.070	1.02	1.78
G	0.100 BSC		2.54 BSC	
H	0.052	0.095	1.32	2.41
J	0.008	0.015	0.20	0.38
K	0.115	0.135	2.92	3.43
L	0.300 BSC		7.62 BSC	
M	0°	10°	0°	10°
N	0.015	0.039	0.39	1.01

MC34001, B MC34002, B MC34004, B
NOTES

MC34001, B MC34002, B MC34004, B
NOTES

MC34001, B MC34002, B MC34004, B

Motorola reserves the right to make changes without further notice to any products herein. Motorola makes no warranty, representation or guarantee regarding the suitability of its products for any particular purpose, nor does Motorola assume any liability arising out of the application or use of any product or circuit, and specifically disclaims any and all liability, including without limitation consequential or incidental damages. "Typical" parameters which may be provided in Motorola data sheets and/or specifications can and do vary in different applications and actual performance may vary over time. All operating parameters, including "Typicals" must be validated for each customer application by customer's technical experts. Motorola does not convey any license under its patent rights nor the rights of others. Motorola products are not designed, intended, or authorized for use as components in systems intended for surgical implant into the body, or other applications intended to support or sustain life, or for any other application in which the failure of the Motorola product could create a situation where personal injury or death may occur. Should Buyer purchase or use Motorola products for any such unintended or unauthorized application, Buyer shall indemnify and hold Motorola and its officers, employees, subsidiaries, affiliates, and distributors harmless against all claims, costs, damages, and expenses, and reasonable attorney fees arising out of, directly or indirectly, any claim of personal injury or death associated with such unintended or unauthorized use, even if such claim alleges that Motorola was negligent regarding the design or manufacture of the part. Motorola and  are registered trademarks of Motorola, Inc. Motorola, Inc. is an Equal Opportunity/Affirmative Action Employer.

How to reach us:

USA/EUROPE/Locations Not Listed: Motorola Literature Distribution;
P.O. Box 20912; Phoenix, Arizona 85036. 1-800-441-2447 or 602-303-5454

MFAX: RMFAX0@email.sps.mot.com – TOUCHTONE 602-244-6609
INTERNET: <http://Design-NET.com>

JAPAN: Nippon Motorola Ltd.; Tatsumi-SPD-JLDC, 6F Seibu-Butsuryu-Center,
3-14-2 Tatsumi Koto-Ku, Tokyo 135, Japan. 03-81-3521-8315

ASIA/PACIFIC: Motorola Semiconductors H.K. Ltd.; 8B Tai Ping Industrial Park,
51 Ting Kok Road, Tai Po, N.T., Hong Kong. 852-26629298



MOTOROLA



MC34001/D

