

Dual A/D Converter

The MC1650 and the MC1651 are very high speed comparators utilizing differential amplifier inputs to sense analog signals above or below a reference level. An output latch provides a unique sample-hold feature. The MC1650 provides high impedance Darlington inputs, while the MC1651 is a lower impedance option, with higher input slew rate and higher speed capability.

The clock inputs (C_A and C_B) operate from MECL III or MECL 10,000 digital levels. When C_A is at a logic high level, Q_0 will be at a logic high level provided that $V_1 > V_2$ (V_1 is more positive than V_2). \bar{Q}_0 is the logic complement of Q_0 . When the clock input goes to a low logic level, the outputs are latched in their present state.

Assessment of the performance differences between the MC1650 and the MC1651 may be based upon the relative behaviors shown in Figures 4 and 7.

MC1650
MC1651

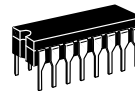

L SUFFIX
CERAMIC PACKAGE
CASE 620-10

LOGIC DIAGRAM

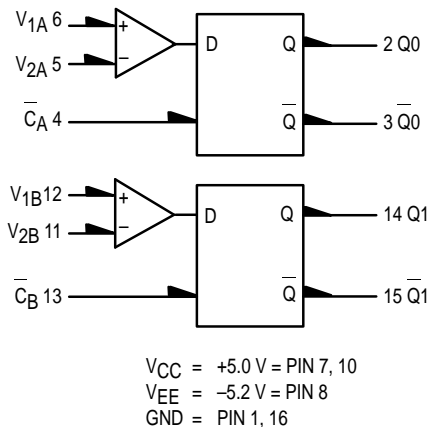

PIN ASSIGNMENT

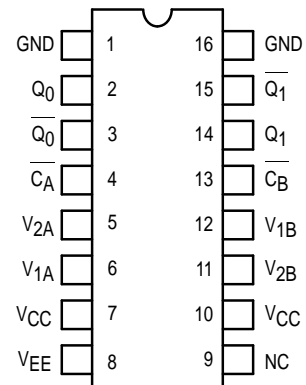

- $P_D = 330 \text{ mW typ/pkg (No Load)}$
- $t_{pd} = 3.5 \text{ ns typ (MC1650)}$
= $3.0 \text{ ns typ (MC1651)}$
- Input Slew Rate = $350 \text{ V}/\mu\text{s (MC1650)}$
= $500 \text{ V}/\mu\text{s (MC1651)}$
- Differential Input Voltage: $5.0 \text{ V (-30}^\circ\text{C to +85}^\circ\text{C)}$
- Common Mode Range:
- $-3.0 \text{ V to +2.5 V (-30}^\circ\text{C to +85}^\circ\text{C (MC1651)}$
- $-2.5 \text{ V to +3.0 V (-30}^\circ\text{C to +85}^\circ\text{C (MC1650)}$
- Resolution: $\leq 20 \text{ mV (-30}^\circ\text{C to +85}^\circ\text{C)}$
- Drives 50Ω lines

Number at end of terminal denotes pin number for L package (Case 620).

TRUTH TABLE

C	V_1, V_2	Q_{0n+1}	Q_{0n+1}
H	$V_1 > V_2$	H	L
H	$V_1 < V_2$	L	H
L	X X	Q_{0n}	Q_{0n}



ELECTRICAL CHARACTERISTICS

Characteristic	Symbol	Test Limits						Unit	
		-30°C		+25°C		+85°C			
		Min	Max	Min	Max	Min	Max		
Power Supply Drain Current	Positive Negative	I_{CC} I_E				25* 55*			mAdc
Input Current	MC1650 MC1651	I_{in}				10 40			μ Adc
Input Leakage Current	MC1650 MC1651	I_R				7.0 10.0			μ Adc
Clock Input Current		I_{inH}				350			
Output Voltage	Logic 1	V_{OH}	-1.045	-0.875	-0.960	-0.810	-0.890	-0.700	Vdc
Output Voltage	Logic 0	V_{OL}	-1.890	-1.650	-1.850	-1.620	-1.830	-1.575	Vdc
Threshold Voltage (Note 2.)	Logic 1	V_{OHA}	-1.065		-0.980		-0.910		Vdc
Threshold Voltage (Note 2.)	Logic 0	V_{OLA}		-1.630		-1.600		-1.555	Vdc

1. All data is for 1/2 MC1650 or MC1651, except data marked (*) which refers to the entire package.

2. These tests are done in order indicated. See Figure 5.

3. Maximum Power Supply Voltages (beyond which device life may be impaired): $|V_{EE}| + |V_{CC}| \geq 12$ Vdc.

4.

All Temperature	V_{A3}	V_{A4}	V_{A5}	V_{A6}
MC1650	+3.0	+2.98	-2.5	-2.48
MC1651	+2.5	+2.48	-3.0	-2.98

MC1650 MC1651

ELECTRICAL CHARACTERISTICS (continued)

		TEST VOLTAGE VALUES (Volts)											
		V _{IHmax}	V _{ILmin}	V _{IHAmin}	V _{ILAmax}	V _{A1}	V _{A2}	V _{A3}	V _{A4}	V _{A5}	V _{A6}	V _{CC} ^{3.}	V _{EE} ^{3.}
@ Test Temperature													
	-30°C	-0.875	-1.890	-1.180	-1.515	+0.02	+0.02	See Note 4.				+5.0	-5.2
	+25°C	-0.810	-1.850	-1.095	-1.485	+0.02	+0.02	See Note 4.				+5.0	-5.2
	+85°C	-0.700	-1.830	-1.025	-1.440	+0.02	+0.02	See Note 4.				+5.0	-5.2
Characteristic	Symbol	TEST VOLTAGE APPLIED TO PINS LISTED BELOW										(V _{CC}) Gnd	
		V _{IHmax}	V _{ILmin}	V _{IHAmin}	V _{ILAmax}	V _{A1}	V _{A2}	V _{A3}	V _{A4}	V _{A5}	V _{A6}		
Power Supply Pos Drain Current Neg	I _{CC} I _E	4,13	4,13			6,12 6,12						1,5,11,16 1,5,11,16	
Input Current MC1650 MC1651	I _{in}	4	13			12		6				1,5,11,16	
Input Leakage Current MC1650 MC1651	I _R	4	13			12				6		1,5,11,16	
Clock Input Current	I _{inH}	4	13			6,12						1,5,11,16	
Output Voltage Logic 1	V _{OH}	4,13				6,12 5,11 6,12 5,11	5,11 6,12	6,12 5,11	5,11 6,12	5,11 6,12	6,12 5,11	1,5,11,16 1,6,12,16 1,16 1,16 1,5,11,16 1,6,12,16 1,16 1,16	
Output Voltage Logic 0	V _{OL}	4,13				5,11 6,12	6,12 5,11	5,11 6,12	6,12 5,11	6,12 5,11	5,11 6,12	1,5,11,16 1,6,12,16 1,16 1,16 1,5,11,16 1,6,12,16 1,16 1,16	
Threshold Voltage Note 2. Logic 1	V _{OHA}		13	4 4	4 4	6 6	6 6					1,5,16	
Threshold Voltage Note 2. Logic 0	V _{OLA}		13	4 4	4 4	6 6	6 6					1,5,16	

1. All data is for 1/2 MC1650 or MC1651, except data marked (*) which refers to the entire package.
2. These tests are done in order indicated. See Figure 5.
3. Maximum Power Supply Voltages (beyond which device life may be impaired): |V_{EE}| + |V_{CC}| ≥ 12 Vdc.

All Temperature	V _{A3}	V _{A4}	V _{A5}	V _{A6}
MC1650	+3.0	+2.98	-2.5	-2.48
MC1651	+2.5	+2.48	-3.0	-2.98

Each MECL 10,000 series circuit has been designed to meet the dc specifications shown in the test table, after thermal equilibrium has been established. The circuit is in a test socket or mounted on a printed circuit board and transverse air flow greater than 500 linear fpm is maintained. Outputs are terminated through a 50-ohm resistor to -2.0 volts. Test procedures are shown for only one gate. The other gates are tested in the same manner.

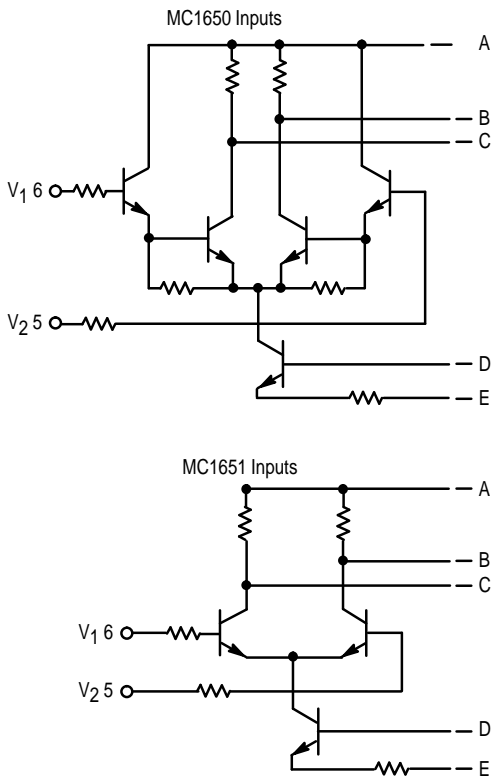

CIRCUIT SCHEMATIC
1/2 of Device Shown

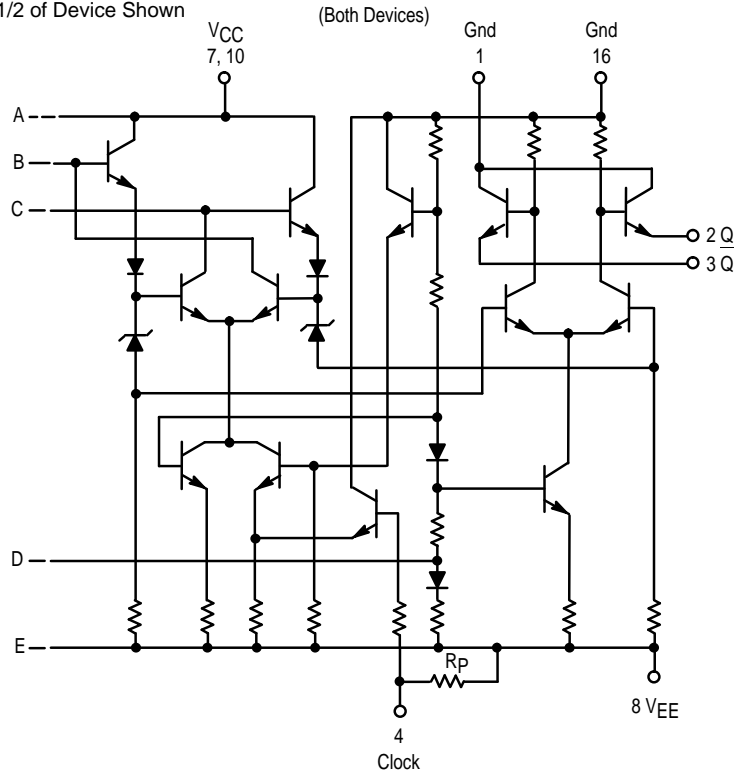

SWITCHING TEST VOLTAGE VALUES							
(Volts)							
@Test Temperature	V _{R1}	V _{R2}	V _{R3}	V _X	V _{XX}	V _{CC} ¹	V _{EE} ¹
-30°C	+2.0	See Note 4		+1.04	+2.0	+7.0	-3.2
+25°C	+2.0			+1.11	+2.0	+7.0	-3.2
+85°C	+2.0			+1.19	+2.0	+7.0	-3.2

Characteristic	Symbol	-30°C		+25°C		+85°C		Unit	Conditions (See Figures 1-3)
		Min	Max	Min	Max	Min	Max		
Switching Times Propagation Delay (50% to 50%) V-Input Clock ²	t _{pd}	2.0	5.0	2.0	5.0	2.0	5.7	ns	V _{R1} to V ₂ , V _X to Clock, P ₁ to V ₁ , or, V _{R2} to V ₂ , V _X to Clock, P ₂ to V ₁ , or, V _{R3} to V ₂ , V _X to Clock, P ₃ to V ₁ .
		2.0	4.7	2.0	4.7	2.0	5.2		
Clock Enable ³	t _{setup}	—	—	2.5	—	—	—	ns	V _{R1} to V ₂ , P ₁ to V ₁ , P ₄ to Clock
Clock Aperture ³	t _{ap}	—	—	1.5	—	—	—	ns	
Rise Time (10% to 90%)	t ₊	1.0	3.5	1.0	3.5	1.0	3.8	ns	
Fall Time (10% to 90%)	t ₋	1.0	3.0	1.0	3.0	1.0	3.3	ns	

NOTES:

- Maximum Power Supply Voltages (beyond which device life may be impaired):
 $|V_{CC}| + |V_{EE}| \geq 12 \text{ Vdc}$.
- Unused clock inputs may be tied to ground.
- See Figure 3.

All Temperatures	V _{R2}	V _{R3}
MC1650	+4.9	-0.4
MC1651	+4.4	-0.9

FIGURE 1 — SWITCHING TIME TEST CIRCUIT @ 25°C

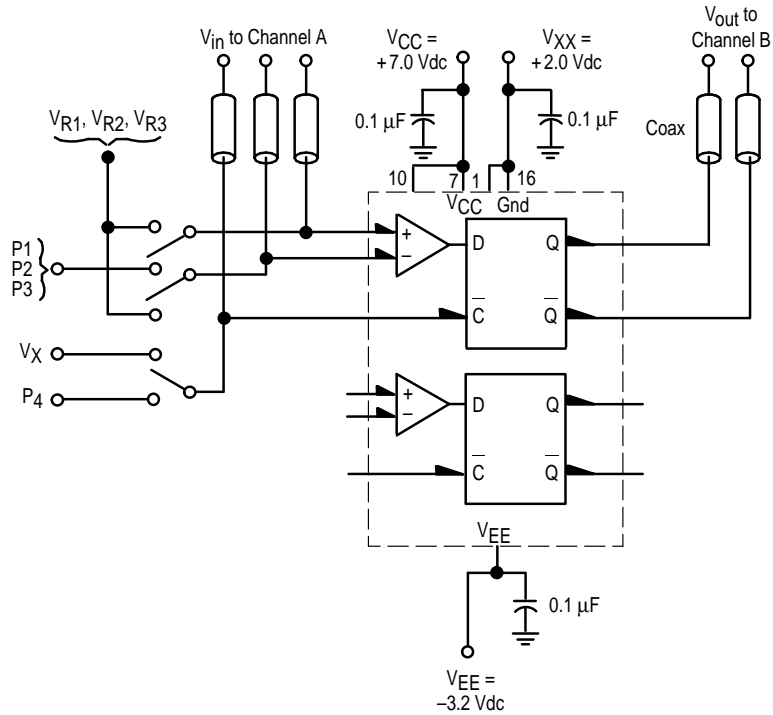

Note: All power supply and logic levels are shown shifted 2.0 volts positive.
 50 ohm termination to ground located in each scope channel input.
 All input and output cables to the scope are equal lengths of 50 ohm coaxial cable.

FIGURE 2 — SWITCHING AND PROPAGATION WAVEFORMS @ 25°C

The pulse levels shown are used to check ac parameters over the full common-mode range.

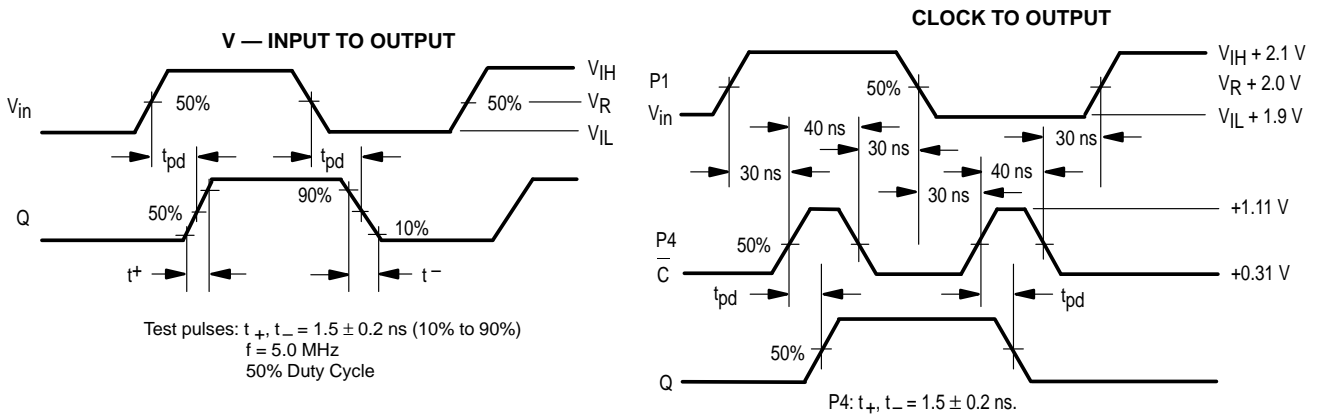

TEST PULSE LEVELS

	P1		P2		P3	
	MC1650	MC1651	MC1650	MC1651	MC1650	MC1651
V_{IH}	+2.1 V	+2.1 V	+5.0 V	+4.5 V	-0.3 V	-0.8 V
V_R	+2.0 V	+2.0 V	+4.9 V	+4.4 V	-0.4 V	-0.9 V
V_{IL}	+1.9 V	+1.9 V	+4.8 V	+4.3 V	-0.5 V	-1.0 V

FIGURE 3 — CLOCK ENABLE AND APERTURE TIME TEST CIRCUIT AND WAVEFORMS @ 25°C

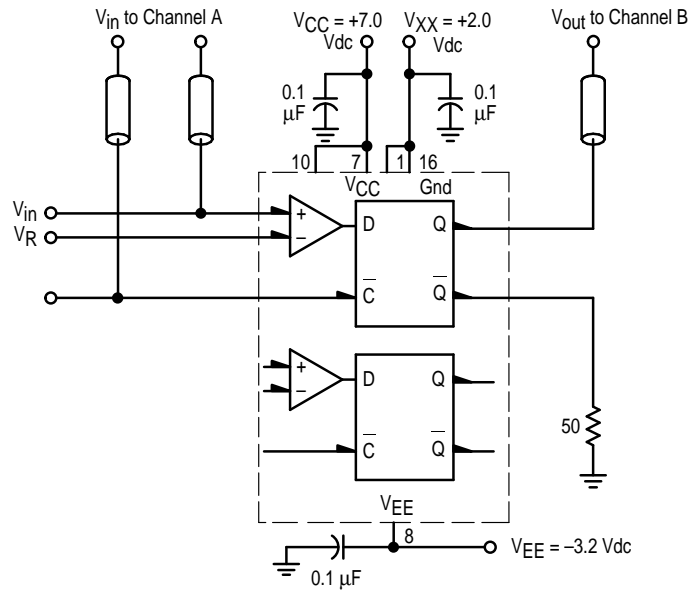

50 ohm termination to ground located in each scope channel input.
 All input and output cables to the scope are equal lengths of 50 ohms coaxial cable.

ANALOG SIGNAL POSITIVE AND NEGATIVE SLEW CASE

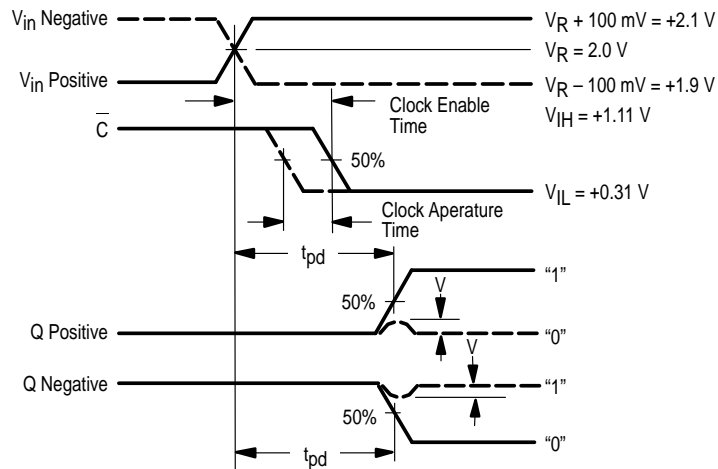

- Clock enable time = minimum time between analog and clock signal such that output switches, and t_{pd} (analog to Q) is not degraded by more than 200 ps.
- - - - - Clock aperture time = time difference between clock enable time and time that output does not switch and V is less than 150 mV.

Note: All power supply and logic levels are shown shifted 2.0 volts positive.

FIGURE 4 — PROPAGATION DELAY (t_{pd}) versus INPUT PULSE AMPLITUDE AND CONSTANT OVERDRIVE

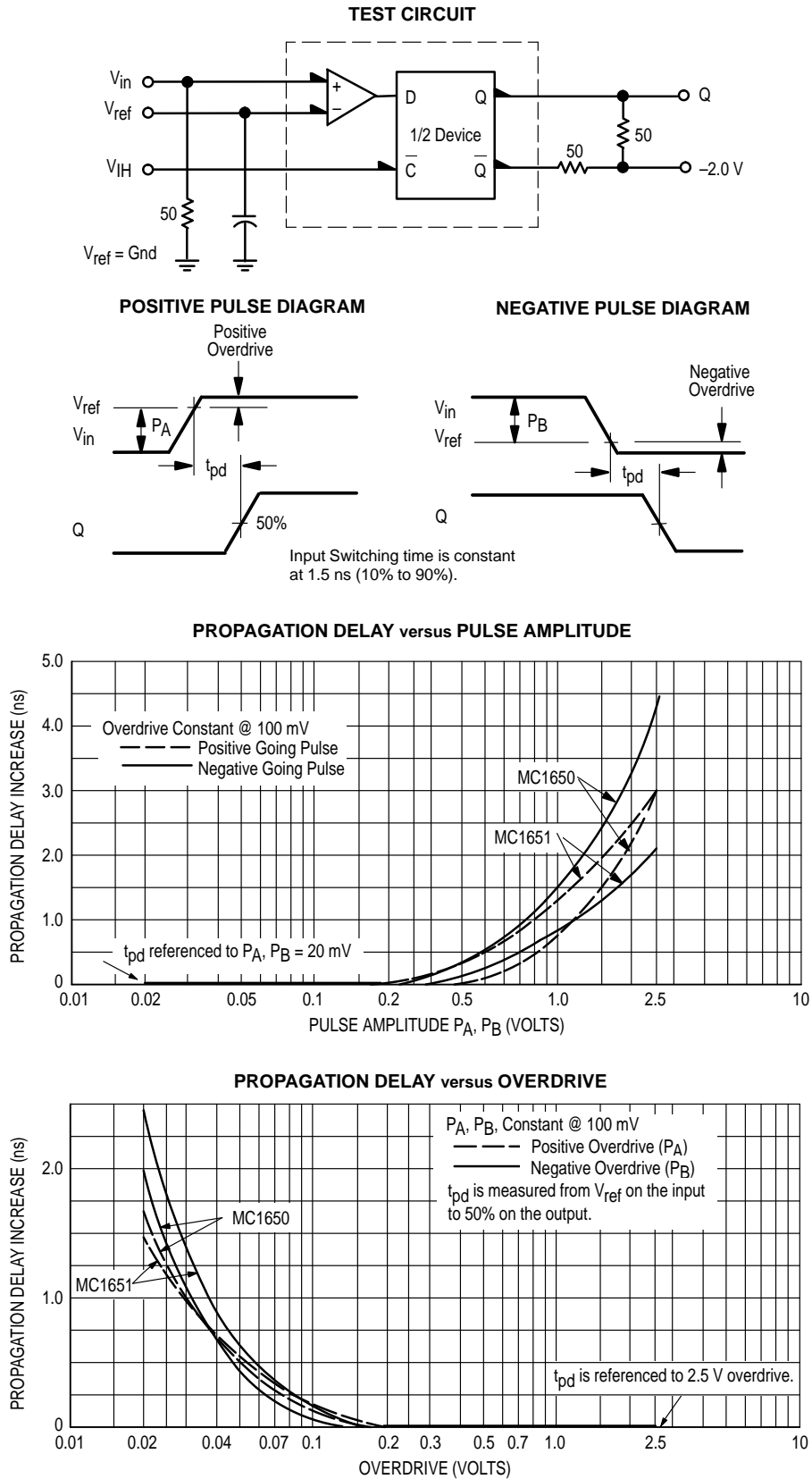

FIGURE 5 — LOGIC THRESHOLD TESTS (WAVEFORM SEQUENCE DIAGRAM)

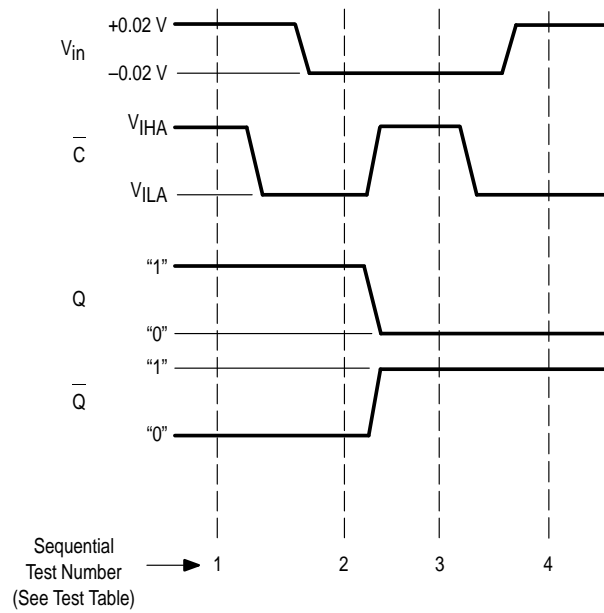
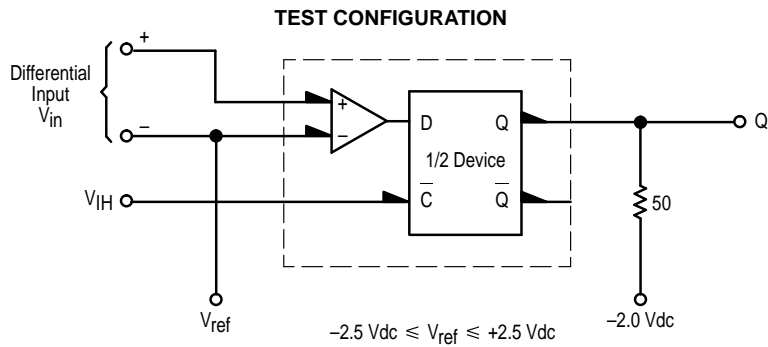

FIGURE 6 — TRANSFER CHARACTERISTICS (Q versus V_{in})



TYPICAL TRANSFER CURVES

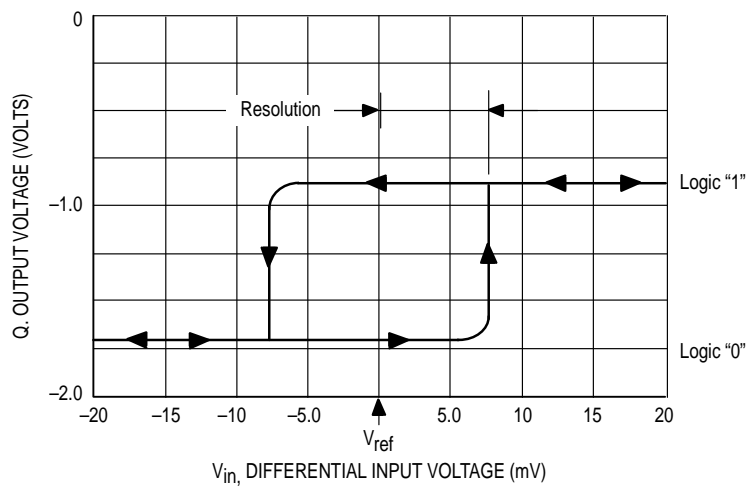
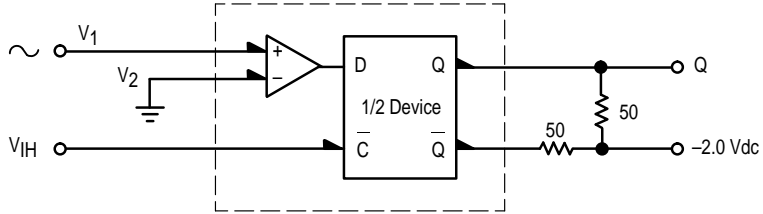

FIGURE 7 — OUTPUT VOLTAGE SWING versus FREQUENCY

(A) TEST CIRCUIT



(B) TYPICAL OUTPUT LOGIC SWING versus FREQUENCY

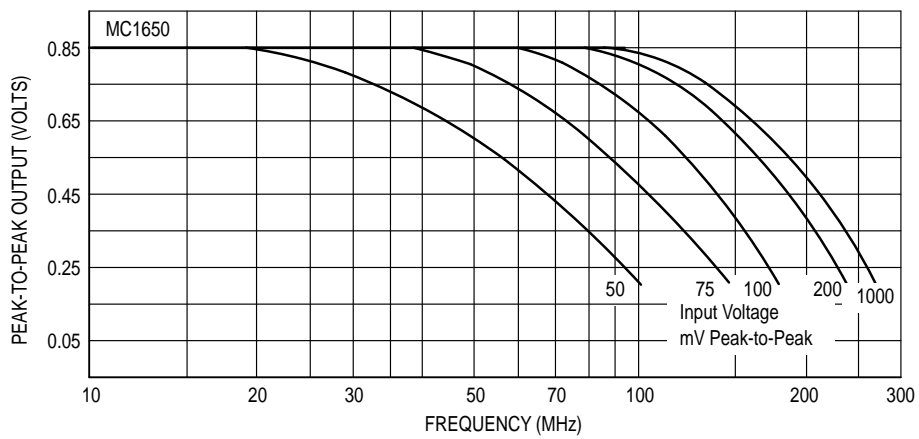
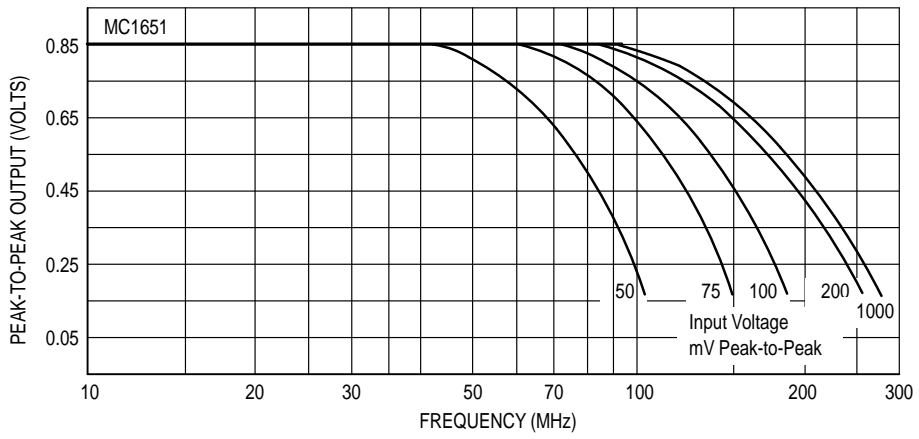
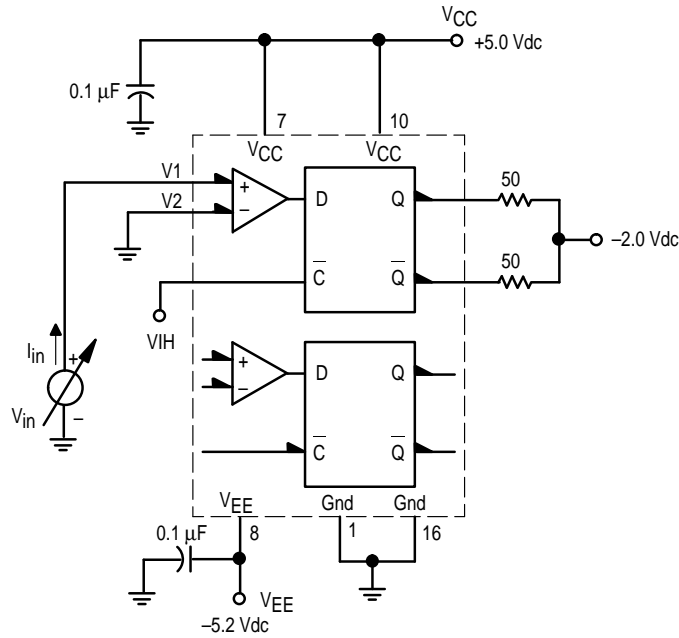
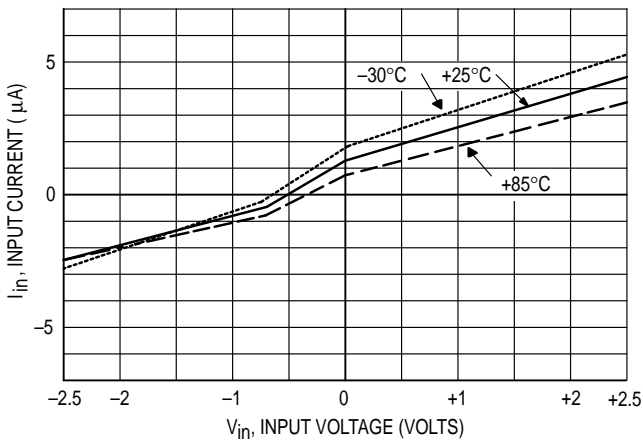

FIGURE 8 — INPUT CURRENT versus INPUT VOLTAGE

TEST CIRCUIT



Typical MC1650 (Complementary Input Grounded)



Typical MC1651 (Complementary Input Grounded)

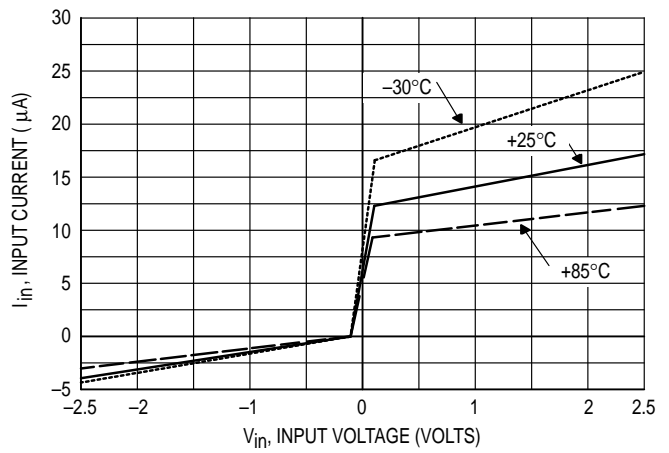

OUTLINE DIMENSIONS

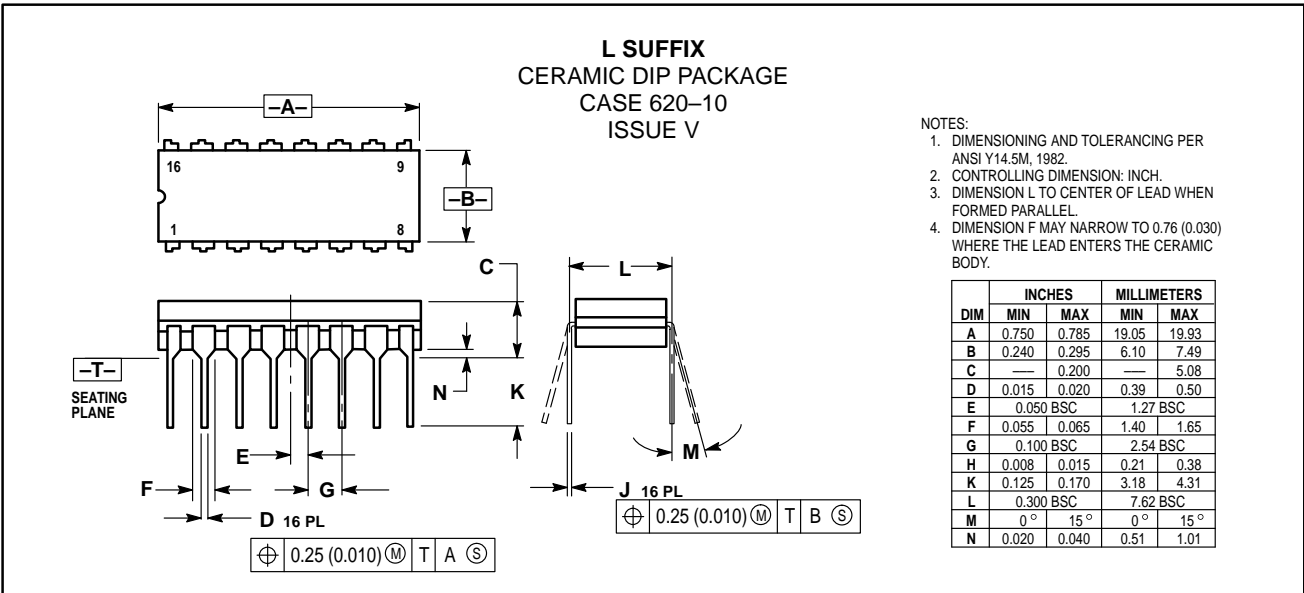

Motorola reserves the right to make changes without further notice to any products herein. Motorola makes no warranty, representation or guarantee regarding the suitability of its products for any particular purpose, nor does Motorola assume any liability arising out of the application or use of any product or circuit, and specifically disclaims any and all liability, including without limitation consequential or incidental damages. "Typical" parameters which may be provided in Motorola data sheets and/or specifications can and do vary in different applications and actual performance may vary over time. All operating parameters, including "Typicals" must be validated for each customer application by customer's technical experts. Motorola does not convey any license under its patent rights nor the rights of others. Motorola products are not designed, intended, or authorized for use as components in systems intended for surgical implant into the body, or other applications intended to support or sustain life, or for any other application in which the failure of the Motorola product could create a situation where personal injury or death may occur. Should Buyer purchase or use Motorola products for any such unintended or unauthorized application, Buyer shall indemnify and hold Motorola and its officers, employees, subsidiaries, affiliates, and distributors harmless against all claims, costs, damages, and expenses, and reasonable attorney fees arising out of, directly or indirectly, any claim of personal injury or death associated with such unintended or unauthorized use, even if such claim alleges that Motorola was negligent regarding the design or manufacture of the part. Motorola and are registered trademarks of Motorola, Inc. Motorola, Inc. is an Equal Opportunity/Affirmative Action Employer.

How to reach us:

USA/EUROPE/Locations Not Listed: Motorola Literature Distribution; P.O. Box 5405, Denver, Colorado 80217. 1-800-441-2447

JAPAN: Nippon Motorola Ltd.; Tatsumi-SPD-JLDC, 6F Seibu-Butsuryu-Center, 3-14-2 Tatsumi Koto-Ku, Tokyo 135, Japan. 03-81-3521-8315

Mfax™: RMFAX0@email.sps.mot.com – TOUCHTONE 602-244-6609
INTERNET: http://Design-NET.com

ASIA/PACIFIC: Motorola Semiconductors H.K. Ltd.; 8B Tai Ping Industrial Park, 51 Ting Kok Road, Tai Po, N.T., Hong Kong. 852-26629298

