



700 kPa Uncompensated Silicon Pressure Sensors

The MPX700 series device is a silicon piezoresistive pressure sensor providing a very accurate and linear voltage output — directly proportional to the applied pressure. This standard, low cost, uncompensated sensor permits manufacturers to design and add their own external temperature compensating and signal conditioning networks. Compensation techniques are simplified because of the predictability of Motorola's single element strain gauge design.

Features

- Low Cost
- Patented, Silicon Shear Stress Strain Gauge Design
- Linearity to $\pm 0.5\%$ (Max) Linearity
- Easy to Use Chip Carrier Package Options
- Ratiometric to Supply Voltage
- 60 mV Span (Typ)
- Absolute, Differential and Gauge Options

Application Examples

- Environmental Control Systems
- Pneumatic Control Systems
- Appliances
- Automotive Performance Controls
- Medical Instrumentation
- Industrial Controls

Figure 1 illustrates a schematic of the internal circuitry on the stand-alone pressure sensor chip.

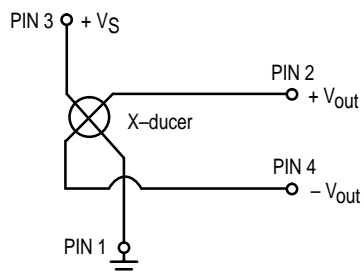

Figure 1. Uncompensated Pressure Sensor Schematic

VOLTAGE OUTPUT versus APPLIED DIFFERENTIAL PRESSURE

The differential voltage output of the X-ducer is directly proportional to the differential pressure applied.

The absolute sensor has a built-in reference vacuum. The output voltage will decrease as vacuum, relative to ambient, is drawn on the pressure (P1) side.

The output voltage of the differential or gauge sensor increases with increasing pressure applied to the pressure (P1) side relative to the vacuum (P2) side. Similarly, output voltage increases as increasing vacuum is applied to the vacuum (P2) side relative to the pressure (P1) side. This sensor is designed for applications where P1 is always greater than, or equal to P2.

Senseon and X-ducer are trademarks of Motorola, Inc.

REV 5

MPX700 SERIES

0 to 700 kPa (0–100 psi)
60 mV FULL SCALE SPAN
(TYPICAL)

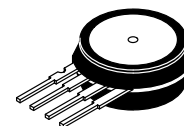

**BASIC CHIP
CARRIER ELEMENT
CASE 344–15, STYLE 1**

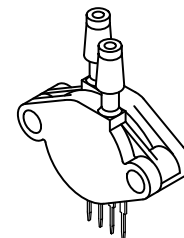

**DIFFERENTIAL
PORT OPTION
CASE 344C–01, STYLE 1**

NOTE: Pin 1 is the notched pin.

PIN NUMBER			
1	Gnd	3	V_S
2	$+V_{out}$	4	$-V_{out}$

MPX700 SERIES

MAXIMUM RATINGS

Rating	Symbol	Value	Unit
Overpressure ⁽⁸⁾ (P2 ≤ 1 Atmosphere)	P1 _{max}	2800	kPa
Burst Pressure ⁽⁸⁾ (P2 ≤ 1 Atmosphere)	P1 _{burst}	5000	kPa
Storage Temperature	T _{stg}	-40 to +125	°C
Operating Temperature	T _A	-40 to +125	°C

OPERATING CHARACTERISTICS (V_S = 3.0 Vdc, T_A = 25°C unless otherwise noted. P1 ≥ P2; P2 ≤ 1 Atmosphere.)

Characteristic	Symbol	Min	Typ	Max	Unit
Pressure Range ⁽¹⁾	P _{OP}	0	—	700	kPa
Supply Voltage ⁽²⁾	V _S	—	3.0	6.0	Vdc
Supply Current	I _o	—	6.0	—	mAdc
Full Scale Span ⁽³⁾	V _{FSS}	45	60	90	mV
Offset ⁽⁴⁾	V _{off}	0	20	35	mV
Sensitivity	ΔV/ΔP	—	86	—	μV/kPa
Linearity ⁽⁵⁾	MPX700D MPX700A	-0.5 -1.0	—	0.5 1.0	%V _{FSS}
Pressure Hysteresis ⁽⁵⁾ (0 to 700 kPa)	—	—	±0.1	—	%V _{FSS}
Temperature Hysteresis ⁽⁵⁾ (-40°C to +125°C)	—	—	±0.5	—	%V _{FSS}
Temperature Coefficient of Full Scale Span ⁽⁵⁾	TCV _{FSS}	-0.21	—	-0.15	%V _{FSS} /°C
Temperature Coefficient of Offset ⁽⁵⁾	TCV _{off}	—	±15	—	μV/°C
Temperature Coefficient of Resistance ⁽⁵⁾	TCR	0.34	—	0.4	%Z _{in} /°C
Input Impedance	Z _{in}	400	—	550	Ω
Output Impedance	Z _{out}	750	—	1800	Ω
Response Time ⁽⁶⁾ (10% to 90%)	t _R	—	1.0	—	ms
Warm-Up ⁽⁷⁾	—	—	20	—	ms

MECHANICAL CHARACTERISTICS

Characteristic	Symbol	Min	Typ	Max	Unit
Weight (Basic Element, Case 344-15)	—	—	2.0	—	Grams

NOTES:

- 1.0 kPa (kiloPascal) equals 0.145 psi.
- Device is ratiometric within this specified excitation range. Operating the device above the specified excitation range may induce additional error due to device self-heating.
- Full Scale Span (V_{FSS}) is defined as the algebraic difference between the output voltage at full rated pressure and the output voltage at the minimum rated pressure.
- Offset (V_{off}) is defined as the output voltage at the minimum rated pressure.
- Accuracy (error budget) consists of the following:
 - Linearity: Output deviation from a straight line relationship with pressure, using end point method, over the specified pressure range.
 - Temperature Hysteresis: Output deviation at any temperature within the operating temperature range, after the temperature is cycled to and from the minimum or maximum operating temperature points, with zero differential pressure applied.
 - Pressure Hysteresis: Output deviation at any pressure within the specified range, when this pressure is cycled to and from the minimum or maximum rated pressure, at 25°C.
 - TcSpan: Output deviation at full rated pressure over the temperature range of 0 to 85°C, relative to 25°C.
 - TcOffset: Output deviation with minimum rated pressure applied, over the temperature range of 0 to 85°C, relative to 25°C.
 - TCR: Z_{in} deviation with minimum rated pressure applied, over the temperature range of -40°C to +125°C, relative to 25°C.
- Response Time is defined as the time for the incremental change in the output to go from 10% to 90% of its final value when subjected to a specified step change in pressure.
- Warm-up is defined as the time required for the device to meet the specified output voltage after the pressure has been stabilized.
- Basic Element only, Case 344-15.
- P2 max : 500 kPa.

TEMPERATURE COMPENSATION

Figure 2 shows the typical output characteristics of the MPX700 series over temperature.

The X-ducer piezoresistive pressure sensor element is a semiconductor device which gives an electrical output signal proportional to the pressure applied to the device. This device uses a unique transverse voltage diffused semiconductor strain gauge which is sensitive to stresses produced in a thin silicon diaphragm by the applied pressure.

Because this strain gauge is an integral part of the silicon diaphragm, there are no temperature effects due to differences in the thermal expansion of the strain gauge and the diaphragm, as are often encountered in bonded strain gauge pressure sensors. However, the properties of the strain gauge itself are temperature dependent, requiring that the device be temperature compensated if it is to be used over an extensive temperature range.

Temperature compensation and offset calibration can be achieved rather simply with additional resistive components

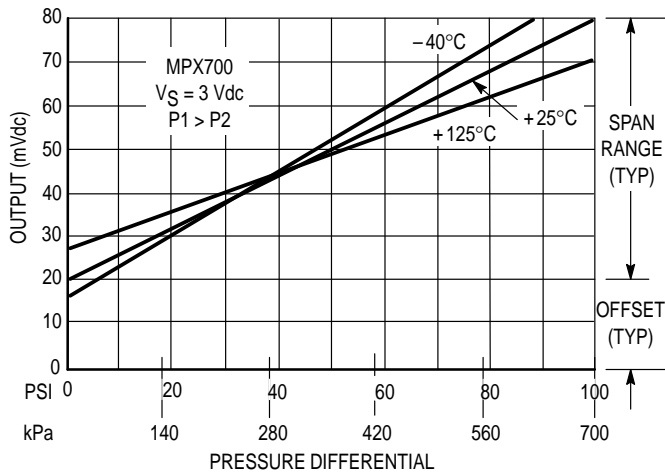

Figure 2. Output versus Pressure Differential

or by designing your system using the MPX2700 series sensors.

Several approaches to external temperature compensation over both -40 to +125°C and 0 to +80°C ranges are presented in Motorola Applications Note AN840.

LINEARITY

Linearity refers to how well a transducer's output follows the equation: $V_{out} = V_{off} + \text{sensitivity} \times P$ over the operating pressure range (Figure 3). There are two basic methods for calculating nonlinearity: (1) end point straight line fit or (2) a least squares best line fit. While a least squares fit gives the "best case" linearity error (lower numerical value), the calculations required are burdensome.

Conversely, an end point fit will give the "worst case" error (often more desirable in error budget calculations) and the calculations are more straightforward for the user. Motorola's specified pressure sensor linearities are based on the end point straight line method measured at the midrange pressure.

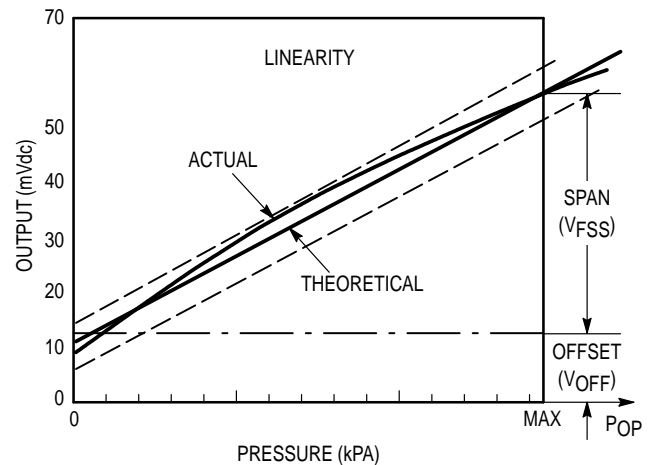

Figure 3. Linearity Specification Comparison

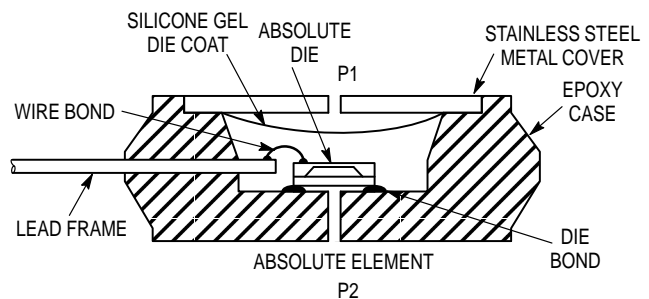
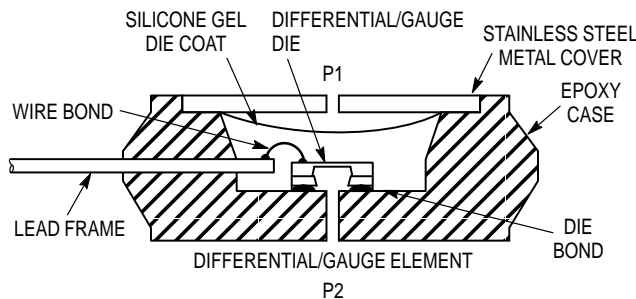

Figure 4. Cross-Sectional Diagrams (not to scale)

Figure 4 illustrates the differential or gauge configuration in the basic chip carrier (Case 344-15). A silicone gel isolates the die surface and wire bonds from the environment, while allowing the pressure signal to be transmitted to the silicon diaphragm.

The MPX700 series pressure sensor operating character-

istics and internal reliability and qualification tests are based on use of dry air as the pressure media. Media other than dry air may have adverse effects on sensor performance and long term reliability. Contact the factory for information regarding media compatibility in your application.

MPX700 SERIES

PRESSURE (P1)/VACUUM (P2) SIDE IDENTIFICATION TABLE

Motorola designates the two sides of the pressure sensor as the Pressure (P1) side and the Vacuum (P2) side. The Pressure (P1) side is the side containing silicone gel which isolates the die from the environment. The differential or gauge sensor is designed to operate with positive differential

pressure applied, $P1 > P2$. The absolute sensor is designed for vacuum applied to P1 side.

The Pressure (P1) side may be identified by using the table on the below:

Part Number	Case Type	Pressure (P1) Side Identifier
MPX700A, MPX700D	344-15	Stainless Steel Cap
MPX700DP	344C-01	Side with Part Marking
MPX700AP, MPX700GP	344B-01	Side with Port Attached
MPX700GVP	344D-01	Stainless Steel Cap
MPX700AS, MPX700GS	344E-01	Side with Port Attached
MPX700ASX, MPX700GSX	344F-01	Side with Port Attached
MPX700GVSX	344G-01	Stainless Steel Cap

ORDERING INFORMATION

MPX700 series pressure sensors are available in differential and gauge configurations. Devices are available in the basic element package or with pressure port fittings which provide printed circuit board mounting ease and barbed hose pressure connections.

Device Type	Options	Case Type	MPX Series	
			Order Number	Device Marking
Basic Element	Absolute, Differential	Case 344-15	MPX700A MPX700D	MPX700A MPX700D
Ported Elements	Differential	Case 344C-01	MPX700DP	MPX700DP
	Absolute, Gauge	Case 344B-01	MPX700AP MPX700GP	MPX700AP MPX700GP
	Gauge Vacuum	Case 344D-01	MPX700GVP	MPX700GVP
	Absolute, Gauge Stove Pipe	Case 344E-01	MPX700AS MPX700GS	MPX700A MPX700D
	Absolute, Gauge Axial	Case 344F-01	MPX700ASX MPX700GSX	MPX700A MPX700D
	Gauge Vacuum Axial	Case 344G-01	MPX700GVSX	MPX700D

PACKAGE DIMENSIONS — CONTINUED

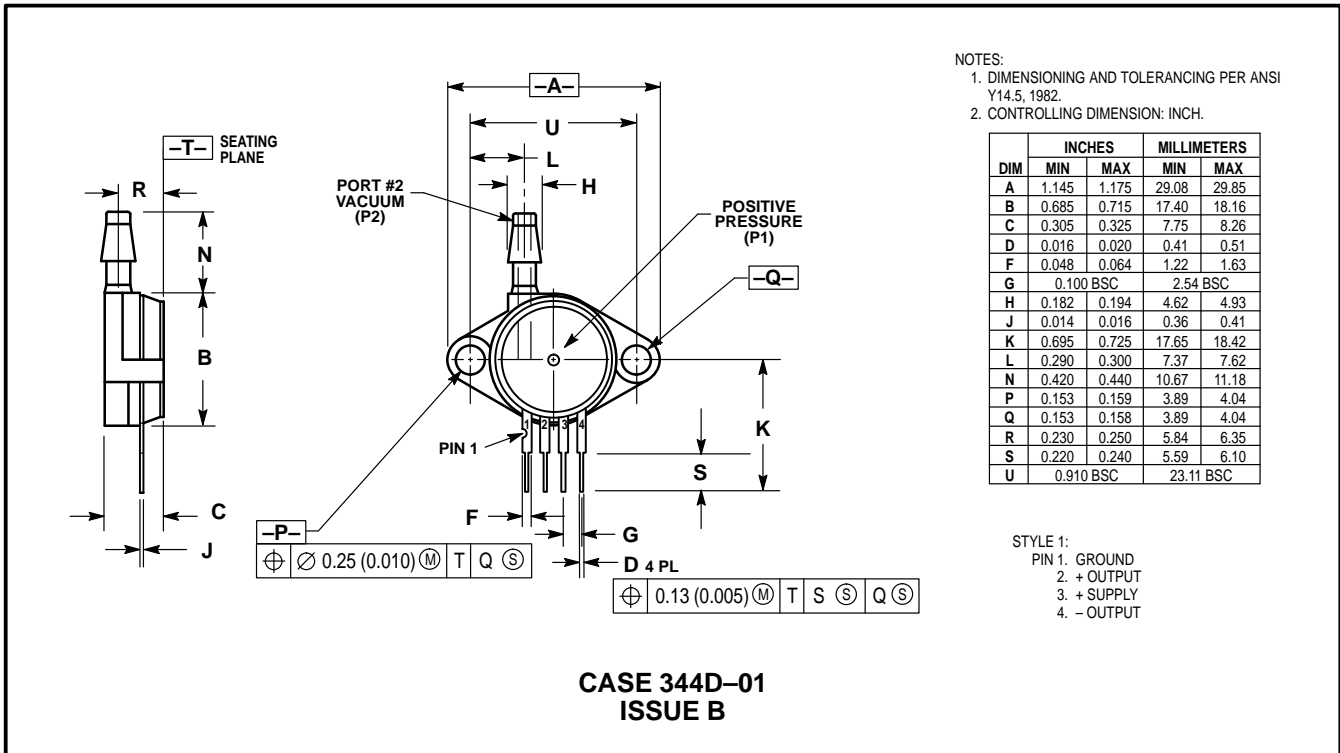
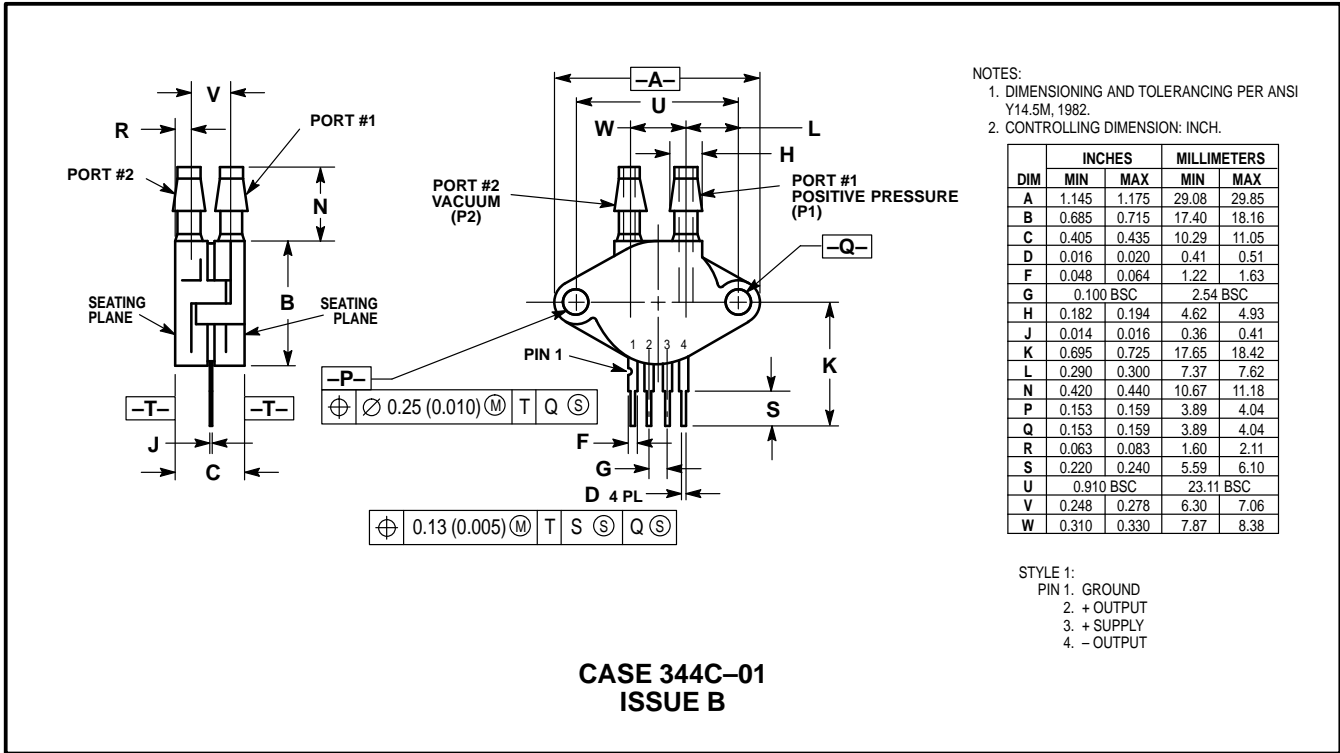

PACKAGE DIMENSIONS — CONTINUED

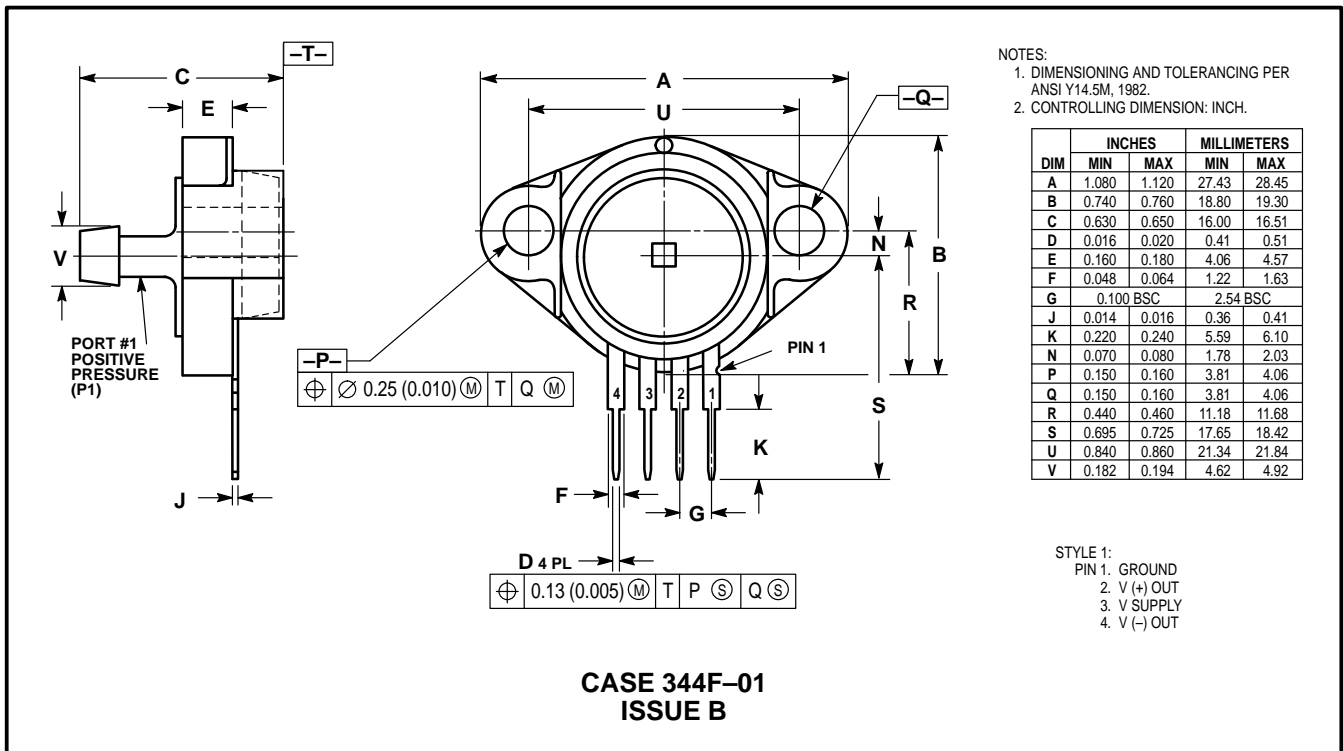
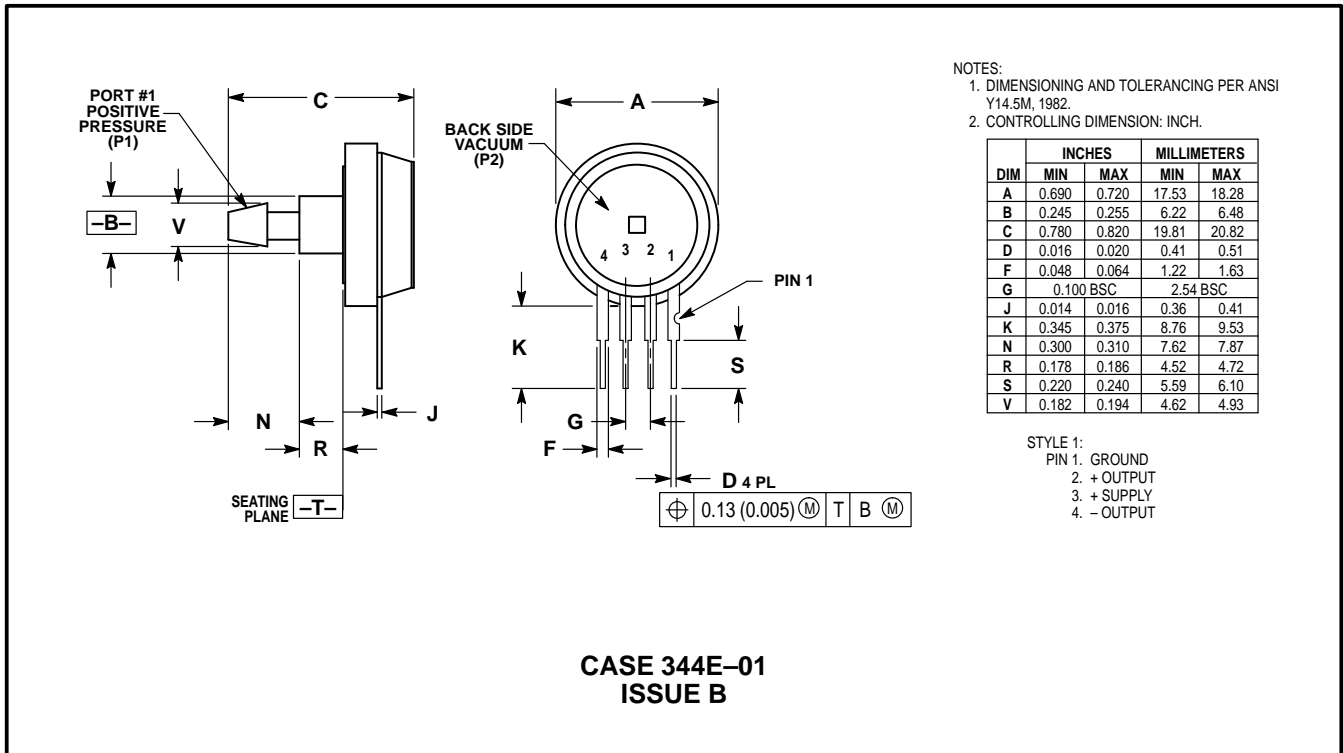

PACKAGE DIMENSIONS — CONTINUED

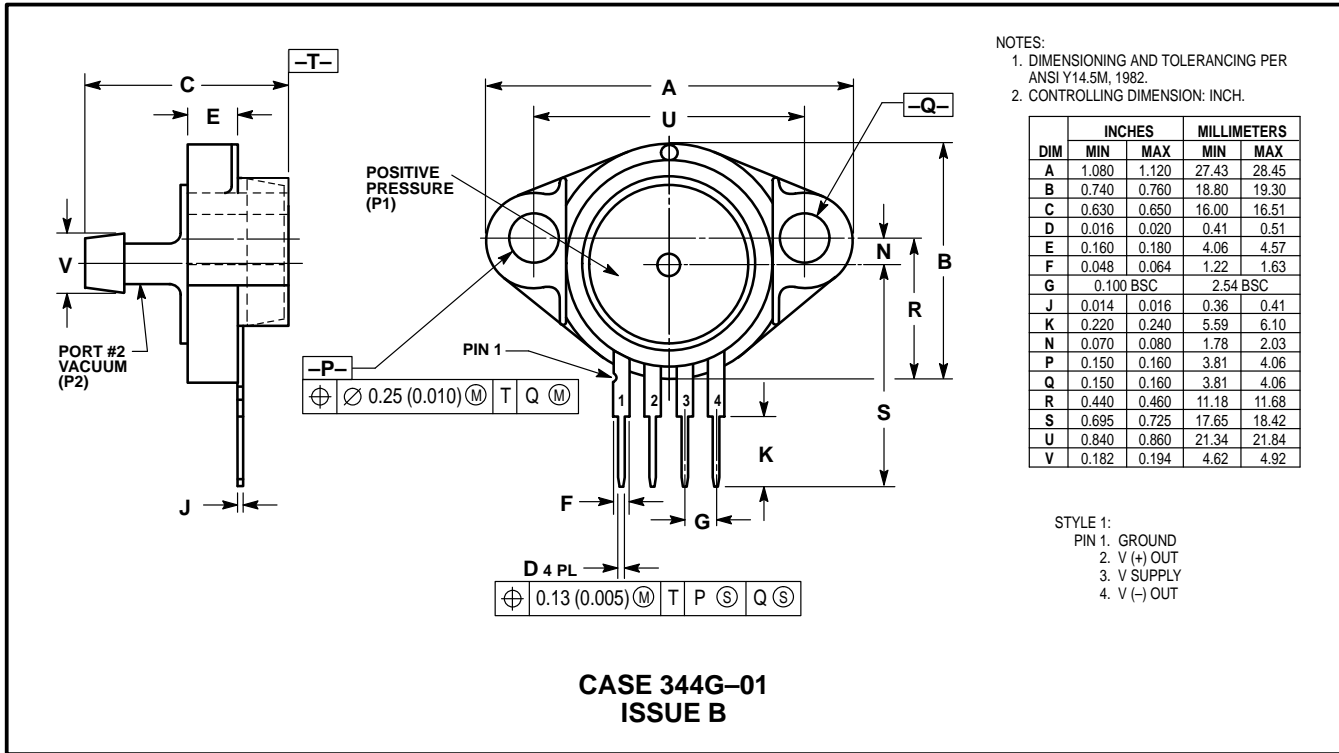

Motorola reserves the right to make changes without further notice to any products herein. Motorola makes no warranty, representation or guarantee regarding the suitability of its products for any particular purpose, nor does Motorola assume any liability arising out of the application or use of any product or circuit, and specifically disclaims any and all liability, including without limitation consequential or incidental damages. "Typical" parameters which may be provided in Motorola data sheets and/or specifications can and do vary in different applications and actual performance may vary over time. All operating parameters, including "Typicals" must be validated for each customer application by customer's technical experts. Motorola does not convey any license under its patent rights nor the rights of others. Motorola products are not designed, intended, or authorized for use as components in systems intended for surgical implant into the body, or other applications intended to support or sustain life, or for any other application in which the failure of the Motorola product could create a situation where personal injury or death may occur. Should Buyer purchase or use Motorola products for any such unintended or unauthorized application, Buyer shall indemnify and hold Motorola and its officers, employees, subsidiaries, affiliates, and distributors harmless against all claims, costs, damages, and expenses, and reasonable attorney fees arising out of, directly or indirectly, any claim of personal injury or death associated with such unintended or unauthorized use, even if such claim alleges that Motorola was negligent regarding the design or manufacture of the part. Motorola and are registered trademarks of Motorola, Inc. Motorola, Inc. is an Equal Opportunity/Affirmative Action Employer.

Mfax is a trademark of Motorola, Inc.

How to reach us:

USA/EUROPE/Locations Not Listed: Motorola Literature Distribution; P.O. Box 5405, Denver, Colorado 80217. 303-675-2140 or 1-800-441-2447

JAPAN: Nippon Motorola Ltd.; Tatsumi-SPD-JLDC, 6F Seibu-Butsuryu-Center, 3-14-2 Tatsumi Koto-Ku, Tokyo 135, Japan. 81-3-3521-8315

Mfax™: RMFAX0@email.sps.mot.com – TOUCHTONE 602-244-6609
 – US & Canada ONLY 1-800-774-1848

ASIA/PACIFIC: Motorola Semiconductors H.K. Ltd.; 8B Tai Ping Industrial Park, 51 Ting Kok Road, Tai Po, N.T., Hong Kong. 852-26629298

INTERNET: <http://motorola.com/sps>

