



200 kPa High Z_{in}, On-Chip Temperature Compensated & Calibrated Silicon Pressure Sensors

The new MPX7200 series pressure sensor incorporates all the innovative features of Motorola's MPX2000 series family including the patented, single piezoresistive strain gauge (X-ducer) and on-chip temperature compensation and calibration. In addition, the MPX7200 series has a high input impedance of typically 10 kΩ for those portable, low power and battery-operated applications. This device is suitable for those systems in which users must have a dependable, accurate pressure sensor that will not consume significant power. The MPX7200 series device is a logical and economical choice for applications such as portable medical instrumentation, remote sensing systems with 4–20 mA transmission and field barometers/altimeters.

Features

- Temperature Compensated Over 0°C to +85°C
- Unique Silicon Shear Stress Strain Gauge
- Easy to Use Chip Carrier Package Options
- Available in Absolute, Differential and Gauge Configurations
- Ratiometric to Supply Voltage
- ±0.25% Linearity (MPX7200D)

Application Examples

- Portable Medical Instrumentation
- Field Altimeters
- Field Barometers

Figure 1 illustrates a schematic of the internal circuitry on the stand-alone pressure sensor chip.

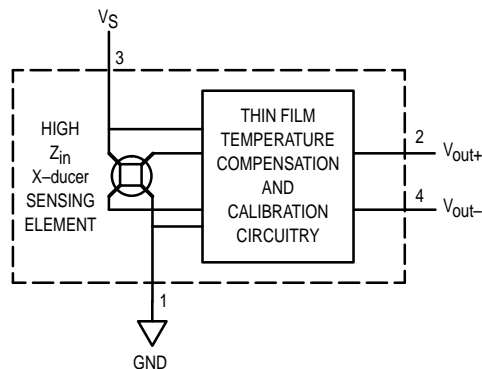

Figure 1. Temperature Compensated Pressure Sensor Schematic

VOLTAGE OUTPUT versus APPLIED DIFFERENTIAL PRESSURE

The differential voltage output of the X-ducer is directly proportional to the differential pressure applied.

The absolute sensor has a built-in reference vacuum. The output voltage will decrease as vacuum, relative to ambient, is drawn on the pressure (P1) side.

The output voltage of the differential or gauge sensor increases with increasing pressure applied to the pressure (P1) side relative to the vacuum (P2) side. Similarly, output voltage increases as increasing vacuum is applied to the vacuum (P2) side relative to the pressure (P1) side.

Preferred devices are Motorola recommended choices for future use and best overall value. Senseon and X-ducer are trademarks of Motorola, Inc.

REV 3

MPX7200 SERIES

Motorola Preferred Device

0 to 200 kPa (0 to 29 psi)
40 mV FULL SCALE SPAN
(TYPICAL)

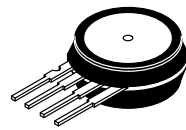

BASIC CHIP
CARRIER ELEMENT
CASE 344-15, STYLE 1

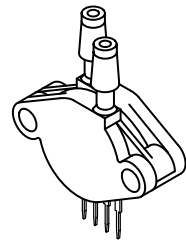

DIFFERENTIAL
PORT OPTION
CASE 344C-01, STYLE 1

NOTE: Pin 1 is the notched pin.

PIN NUMBER			
1	Gnd	3	V _S
2	+V _{out}	4	-V _{out}

MPX7200 SERIES

MAXIMUM RATINGS

Rating	Symbol	Value	Unit
Overpressure ⁽⁸⁾ (P1 > P2)	P _{max}	400	kPa
Burst Pressure ⁽⁸⁾ (P1 > P2)	P _{burst}	2000	kPa
Storage Temperature	T _{stg}	-40 to +125	°C
Operating Temperature	T _A	-40 to +125	°C

OPERATING CHARACTERISTICS (V_S = 10 Vdc, T_A = 25°C unless otherwise noted, P1 > P2)

Characteristic	Symbol	Min	Typ	Max	Unit	
Pressure Range ⁽¹⁾	P _{OP}	0	—	200	kPa	
Supply Voltage ⁽²⁾	V _S	—	10	16	Vdc	
Supply Current	I _o	—	1.0	—	mAdc	
Full Scale Span ⁽³⁾	MPX7200A, MPX7200D	V _{FSS}	38.5	40	41.5	mV
Offset ⁽⁴⁾	MPX7200D	V _{off}	-1.0	—	1.0	mV
	MPX7200A		-2.0	—	2.0	
Sensitivity	ΔV/ΔP	—	0.2	—	mV/kPa	
Linearity ⁽⁵⁾	MPX7200D	—	-0.25	—	0.25	%V _{FSS}
	MPX7200A	—	-1.0	—	1.0	
Pressure Hysteresis ⁽⁵⁾ (0 to 200 kPa)	—	—	±0.1	—	%V _{FSS}	
Temperature Hysteresis ⁽⁵⁾ (-40°C to +125°C)	—	—	±0.5	—	%V _{FSS}	
Temperature Effect on Full Scale Span ⁽⁵⁾	TCV _{FSS}	-1.0	—	1.0	%V _{FSS}	
Temperature Effect on Offset ⁽⁵⁾	TCV _{off}	-1.0	—	1.0	mV	
Input Impedance	Z _{in}	5000	—	15,000	Ω	
Output Impedance	Z _{out}	2500	—	6000	Ω	
Response Time ⁽⁶⁾	t _R	—	1.0	—	ms	
Warm-Up	—	—	20	—	ms	
Offset Stability ⁽⁹⁾	—	—	±0.5	—	%V _{FSS}	

MECHANICAL CHARACTERISTICS

Characteristic	Symbol	Min	Typ	Max	Unit
Weight (Basic Element Case 344-15)	—	—	2.0	—	Grams
Common Mode Line Pressure ⁽⁷⁾	—	—	—	690	kPa

NOTES:

- 1.0 kPa (kiloPascal) equals 0.145 psi.
- Device is ratiometric within this specified excitation range. Operating the device above the specified excitation range may induce additional error due to device self-heating.
- Full Scale Span (V_{FSS}) is defined as the algebraic difference between the output voltage at full rated pressure and the output voltage at the minimum rated pressure.
- Offset (V_{off}) is defined as the output voltage at the minimum rated pressure.
- Accuracy (error budget) consists of the following:
 - Linearity: Output deviation from a straight line relationship with pressure, using end point method, over the specified pressure range.
 - Temperature Hysteresis: Output deviation at any temperature within the operating temperature range, after the temperature is cycled to and from the minimum or maximum operating temperature points, with zero differential pressure applied.
 - Pressure Hysteresis: Output deviation at any pressure within the specified range, when this pressure is cycled to and from the minimum or maximum rated pressure, at 25°C.
 - TcSpan: Output deviation at full rated pressure over the temperature range of 0 to 85°C, relative to 25°C.
 - TcOffset: Output deviation with minimum rated pressure applied, over the temperature range of 0 to 85°C, relative to 25°C.
- Response Time is defined as the time for the incremental change in the output to go from 10% to 90% of its final value when subjected to a specified step change in pressure.
- Common mode pressures beyond specified may result in leakage at the case-to-lead interface.
- Exposure beyond these limits may cause permanent damage or degradation to the device.
- Offset stability is the product's output deviation when subjected 1000 hours of Pulsed Pressure, Temperature Cycling with Bias Test.

LINEARITY

Linearity refers to how well a transducer's output follows the equation: $V_{out} = V_{off} + \text{sensitivity} \times P$ over the operating pressure range. There are two basic methods for calculating nonlinearity: (1) end point straight line fit (see Figure 2) or (2) a least squares best line fit. While a least squares fit gives the "best case" linearity error (lower numerical value), the calculations required are burdensome.

Conversely, an end point fit will give the "worst case" error (often more desirable in error budget calculations) and the calculations are more straightforward for the user. Motorola's specified pressure sensor linearities are based on the end point straight line method measured at the midrange pressure.

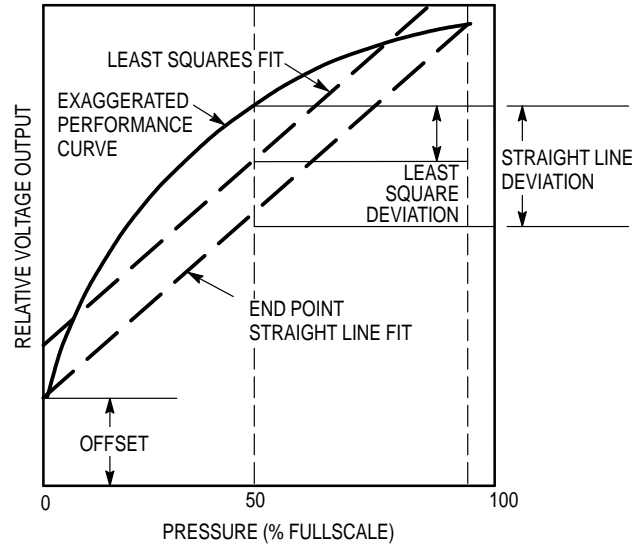

Figure 2. Linearity Specification Comparison

ON-CHIP TEMPERATURE COMPENSATION and CALIBRATION

Figure 3 shows the output characteristics of the MPX7200 series at 25°C. The output is directly proportional to the differential pressure and is essentially a straight line.

The effects of temperature on Full Scale Span and Offset are very small and are shown under Operating Characteristics.

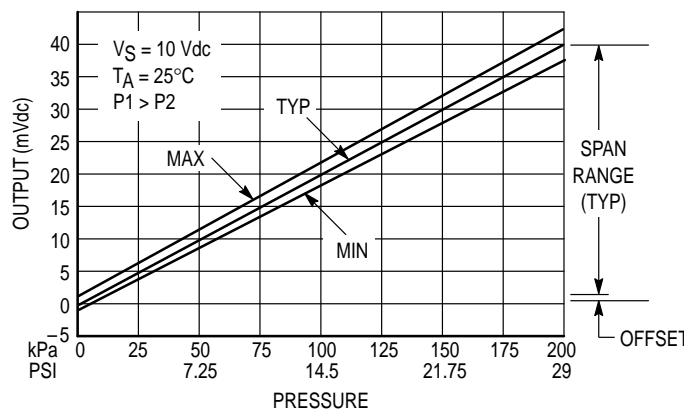

Figure 3. Output versus Pressure Differential

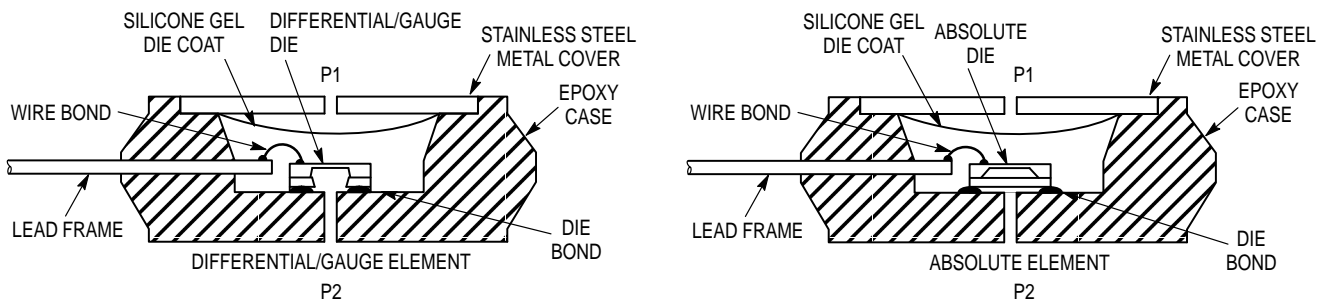

Figure 4. Cross-Sectional Diagrams (Not to Scale)

Figure 4 illustrates the absolute sensing configuration (right) and the differential or gauge configuration in the basic chip carrier (Case 344-15). A silicone gel isolates the die surface and wire bonds from the environment, while allowing the pressure signal to be transmitted to the silicon diaphragm.

The MPX7200 series pressure sensor operating charac-

teristics and internal reliability and qualification tests are based on use of dry air as the pressure media. Media other than dry air may have adverse effects on sensor performance and long term reliability. Contact the factory for information regarding media compatibility in your application.

MPX7200 SERIES

PRESSURE (P1)/VACUUM (P2) SIDE IDENTIFICATION TABLE

Motorola designates the two sides of the pressure sensor as the Pressure (P1) side and the Vacuum (P2) side. The Pressure (P1) side is the side containing the silicone gel which isolates the die from the environment. The differential and gauge sensor is designed to operate with positive differ-

ential pressure applied, $P1 > P2$. The absolute sensor is designed for vacuum applied to P1 side.

The Pressure (P1) side may be identified by using the table below:

Part Number		Case Type	Pressure Side (P1) Identifier
MPX7200A	MPX7200D	344-15	Stainless Steel Cap
MPX7200DP		344C-01	Side with Part Marking
MPX7200AP	MPX7200GP	344B-01	Side with Port Attached
MPX7200GVP		344D-01	Stainless Steel Cap
MPX7200AS		344E-01	Side with Port Attached
MPX7200ASX	MPX7200GSX	344F-01	Side with Port Attached
MPX7200GVSX		344G-01	Stainless Steel Cap

ORDERING INFORMATION

MPX7200 series pressure sensors are available in absolute, differential and gauge configurations. Devices are available in the basic element package or with pressure port fittings which provide printed circuit board mounting ease and barbed hose pressure connections.

Device Type	Options	Case Type	MPX Series	
			Order Number	Device Marking
Basic Element	Absolute, Differential	Case 344-15	MPX7200A MPX7200D	MPX7200A MPX7200D
Ported Elements	Differential	Case 344C-01	MPX7200DP	MPX7200DP
	Absolute, Gauge	Case 344B-01	MPX7200AP MPX7200D	MPX7200AP MPX7200GP
	Gauge Vacuum	Case 344D-01	MPX7200GVP	MPX7200GVP
	Absolute, Stove Pipe	Case 344E-01	MPX7200AS	MPX7200A
	Absolute, Gauge Axial	Case 344F-01	MPX7200ASX MPX7200GSX	MPX7200A MPX7200D
	Gauge Vacuum Axial	Case 344G-01	MPX7200GVSX	MPX7200D

PACKAGE DIMENSIONS

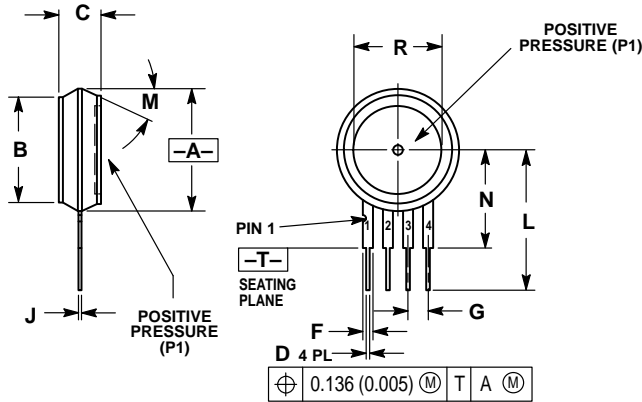

NOTES:

1. DIMENSIONING AND TOLERANCING PER ASME Y14.5M, 1994.
2. CONTROLLING DIMENSION: INCH.
3. DIMENSION -A- IS INCLUSIVE OF THE MOLD STOP RING. MOLD STOP RING NOT TO EXCEED 16.00 (0.630).

DIM	INCHES		MILLIMETERS	
	MIN	MAX	MIN	MAX
A	0.595	0.630	15.11	16.00
B	0.514	0.534	13.06	13.56
C	0.200	0.220	5.08	5.59
D	0.016	0.020	0.41	0.51
F	0.048	0.064	1.22	1.63
G	0.100 BSC		2.54 BSC	
J	0.014	0.016	0.36	0.40
L	0.695	0.725	17.65	18.42
M	30° NOM		30° NOM	
N	0.475	0.495	12.07	12.57
R	0.430	0.450	10.92	11.43

STYLE 1:

- PIN 1. GROUND
- + OUTPUT
- + SUPPLY
- OUTPUT

**CASE 344-15
ISSUE W**

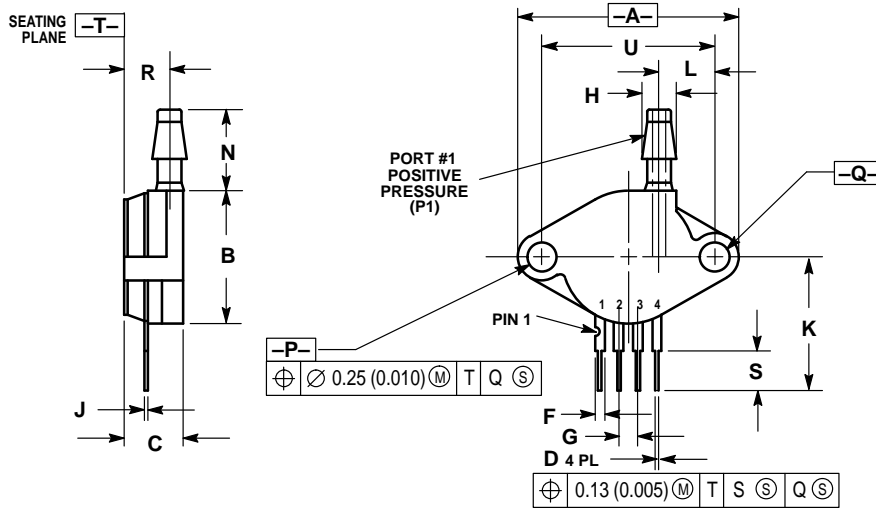

NOTES:

1. DIMENSIONING AND TOLERANCING PER ANSI Y14.5, 1982.
2. CONTROLLING DIMENSION: INCH.

DIM	INCHES		MILLIMETERS	
	MIN	MAX	MIN	MAX
A	1.145	1.175	29.08	29.85
B	0.685	0.715	17.40	18.16
C	0.305	0.325	7.75	8.26
D	0.016	0.020	0.41	0.51
F	0.048	0.064	1.22	1.63
G	0.100 BSC		2.54 BSC	
H	0.182	0.194	4.62	4.93
J	0.014	0.016	0.36	0.41
K	0.695	0.725	17.65	18.42
L	0.290	0.300	7.37	7.62
N	0.420	0.440	10.67	11.18
P	0.153	0.159	3.89	4.04
Q	0.153	0.159	3.89	4.04
R	0.230	0.250	5.84	6.35
S	0.220	0.240	5.59	6.10
U	0.910 BSC		23.11 BSC	

STYLE 1:

- PIN 1. GROUND
- + OUTPUT
- + SUPPLY
- OUTPUT

**CASE 344B-01
ISSUE B**

PACKAGE DIMENSIONS — CONTINUED

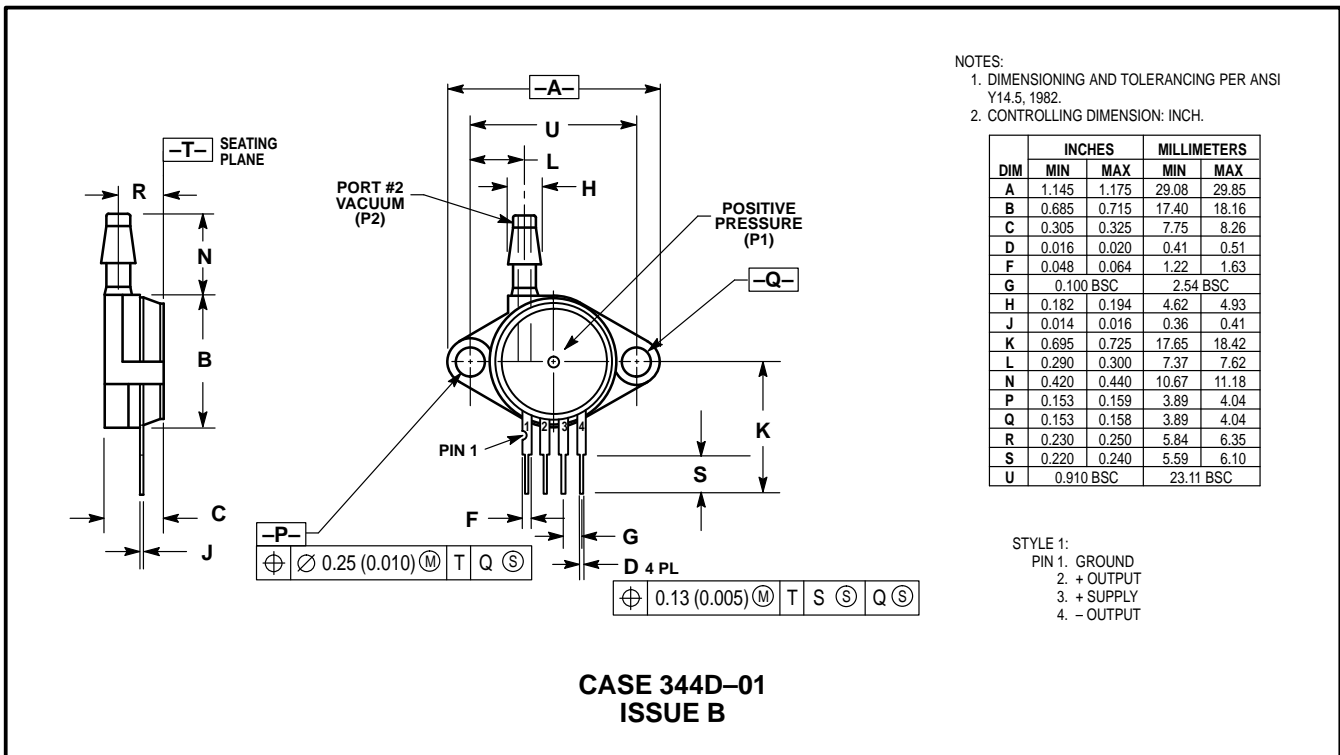
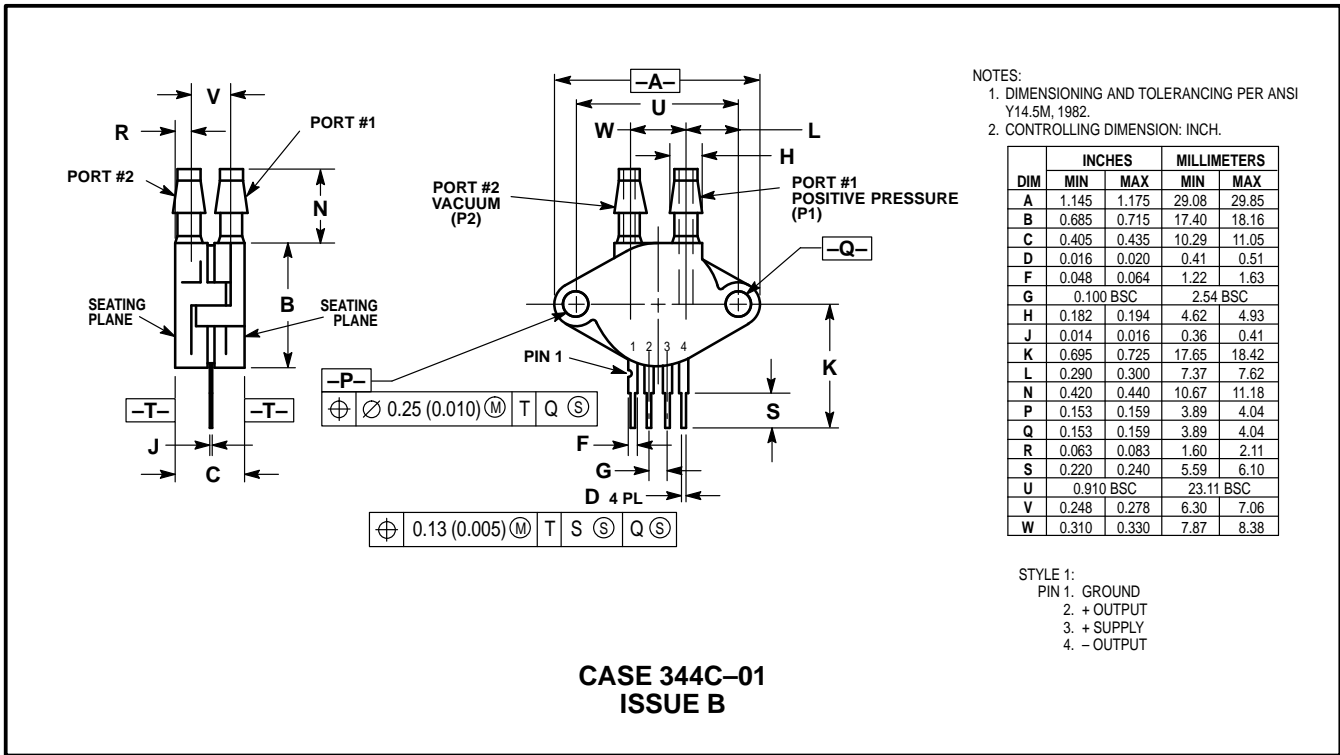

PACKAGE DIMENSIONS — CONTINUED

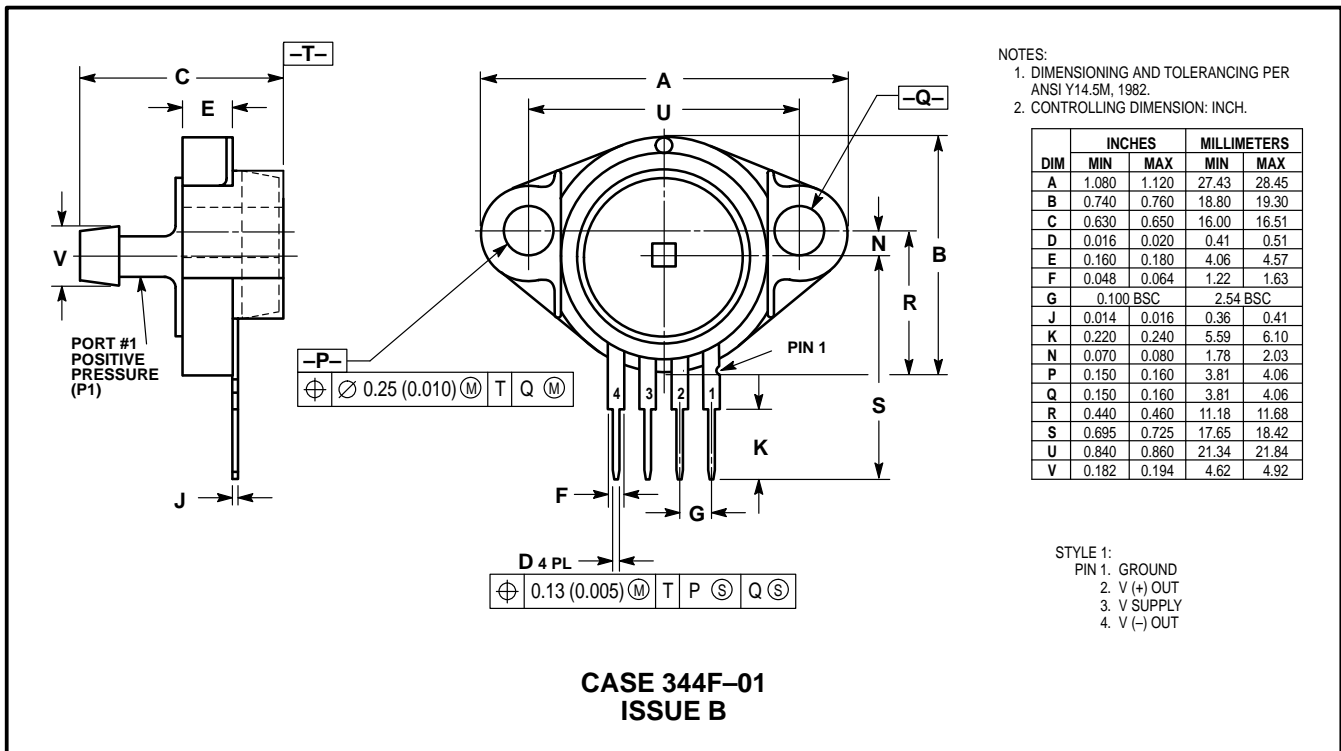
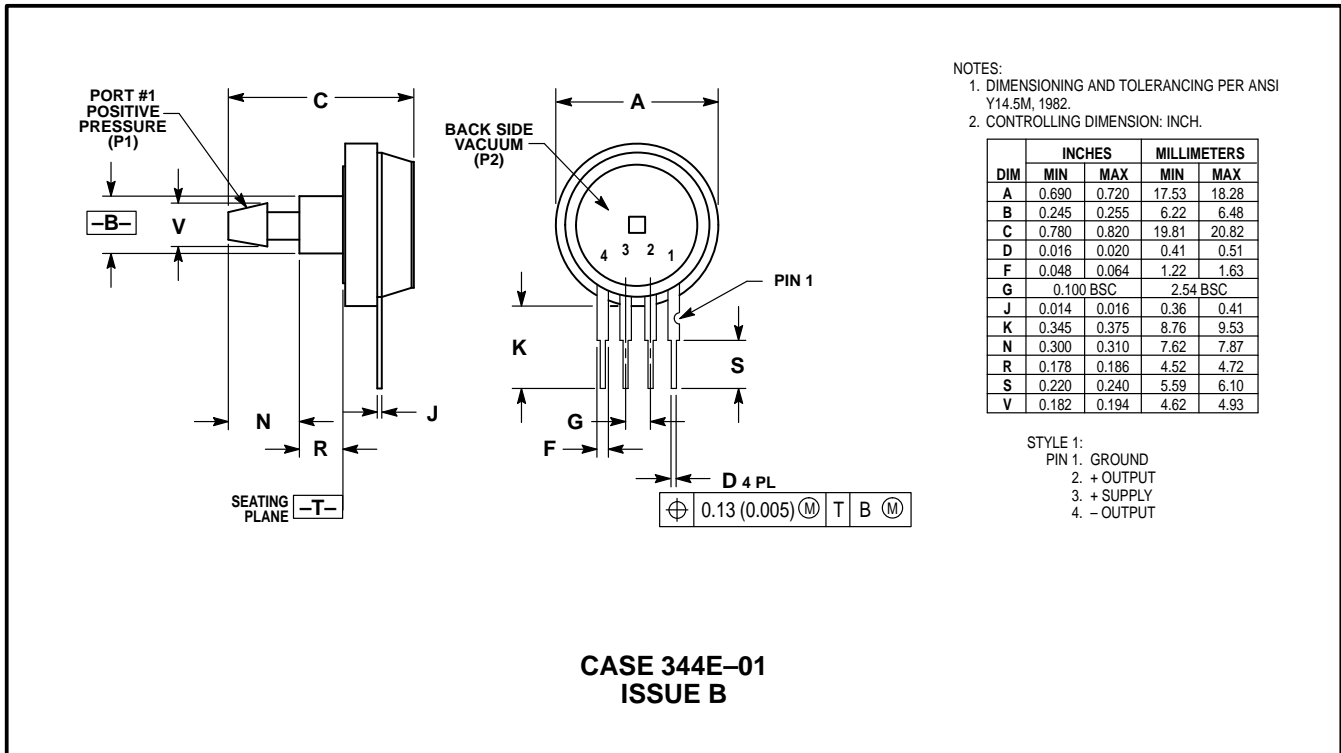

PACKAGE DIMENSIONS — CONTINUED

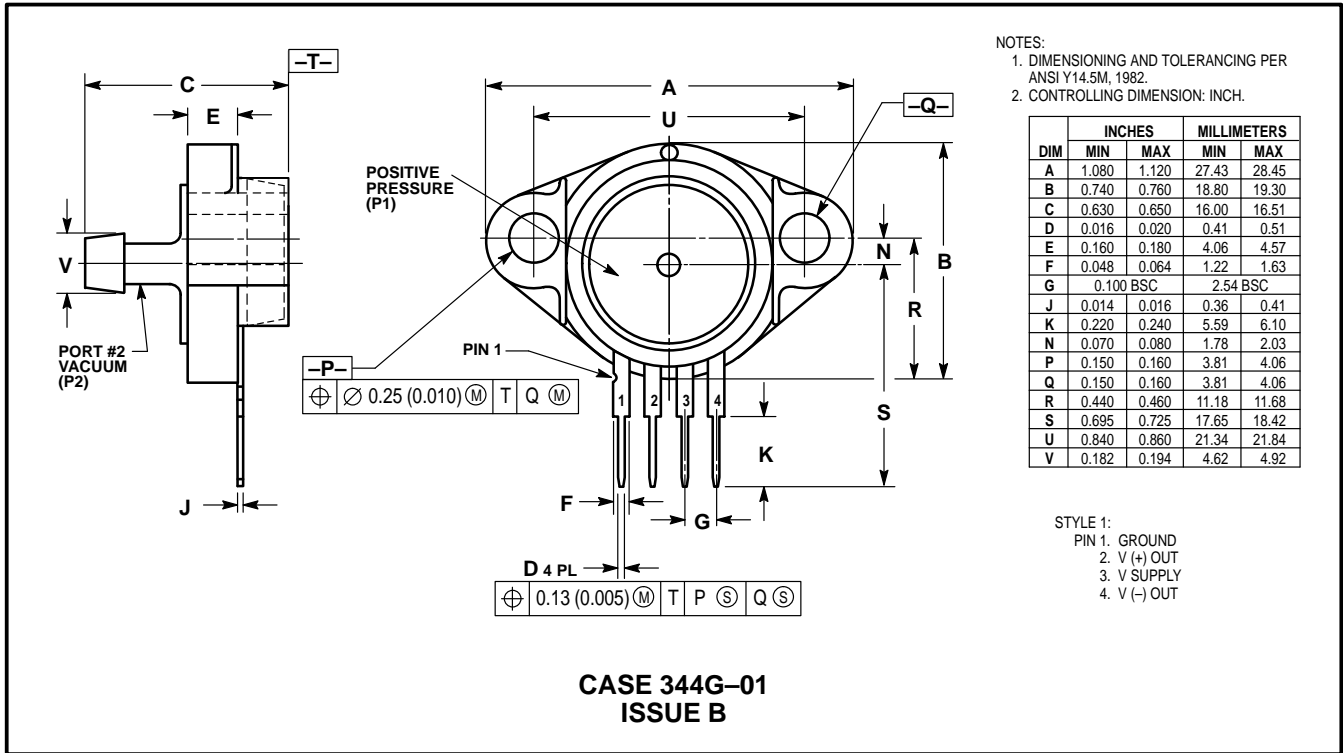

Motorola reserves the right to make changes without further notice to any products herein. Motorola makes no warranty, representation or guarantee regarding the suitability of its products for any particular purpose, nor does Motorola assume any liability arising out of the application or use of any product or circuit, and specifically disclaims any and all liability, including without limitation consequential or incidental damages. "Typical" parameters which may be provided in Motorola data sheets and/or specifications can and do vary in different applications and actual performance may vary over time. All operating parameters, including "Typicals" must be validated for each customer application by customer's technical experts. Motorola does not convey any license under its patent rights nor the rights of others. Motorola products are not designed, intended, or authorized for use as components in systems intended for surgical implant into the body, or other applications intended to support or sustain life, or for any other application in which the failure of the Motorola product could create a situation where personal injury or death may occur. Should Buyer purchase or use Motorola products for any such unintended or unauthorized application, Buyer shall indemnify and hold Motorola and its officers, employees, subsidiaries, affiliates, and distributors harmless against all claims, costs, damages, and expenses, and reasonable attorney fees arising out of, directly or indirectly, any claim of personal injury or death associated with such unintended or unauthorized use, even if such claim alleges that Motorola was negligent regarding the design or manufacture of the part. Motorola and are registered trademarks of Motorola, Inc. Motorola, Inc. is an Equal Opportunity/Affirmative Action Employer.

Mfax is a trademark of Motorola, Inc.

How to reach us:

USA/EUROPE/Locations Not Listed: Motorola Literature Distribution; P.O. Box 5405, Denver, Colorado 80217. 303-675-2140 or 1-800-441-2447

JAPAN: Nippon Motorola Ltd.; Tatsumi-SPD-JLDC, 6F Seibu-Butsuryu-Center, 3-14-2 Tatsumi Koto-Ku, Tokyo 135, Japan. 81-3-3521-8315

Mfax™: RMFAX0@email.sps.mot.com – TOUCHTONE 602-244-6609
 – US & Canada ONLY 1-800-774-1848

ASIA/PACIFIC: Motorola Semiconductors H.K. Ltd.; 8B Tai Ping Industrial Park, 51 Ting Kok Road, Tai Po, N.T., Hong Kong. 852-26629298

INTERNET: <http://motorola.com/sps>

