



1-OF-8 DECODER/ DEMULTIPLEXER

The MC54/74F138 is a high speed 1-of-8 Decoder/Demultiplexer. This device is ideally suited for high speed bipolar memory chip select address decoding. The multiple input enables allow parallel expansion to a 1-of-24 decoder using just three F138 devices or to a 1-of-32 decoder using four F138s and one inverter.

- Demultiplexing Capability
- Multiple Input Enable for Easy Expansion
- Active Low Mutually Exclusive Outputs
- Input Clamp Diodes Limit High-Speed Termination Effects

CONNECTION DIAGRAM DIP (TOP VIEW)

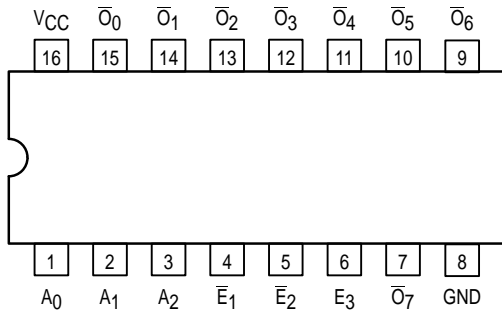

LOGIC DIAGRAM

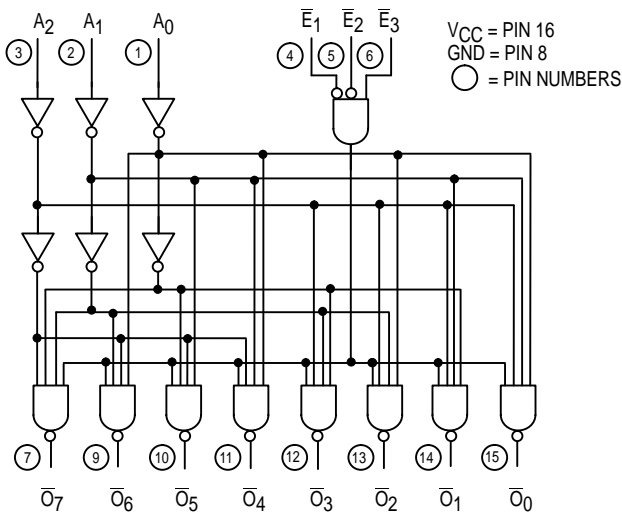

MC54/74F138

1-OF-8 DECODER/ DEMULTIPLEXER FAST™ SHOTTKY TTL

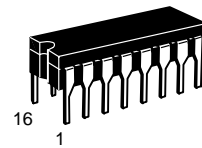

J SUFFIX
CERAMIC
CASE 620-09

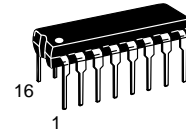

N SUFFIX
PLASTIC
CASE 648-08

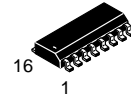

D SUFFIX
SOIC
CASE 751B-03

ORDERING INFORMATION

MC54FXXXJ	Ceramic
MC74FXXXN	Plastic
MC74FXXXD	SOIC

LOGIC SYMBOL

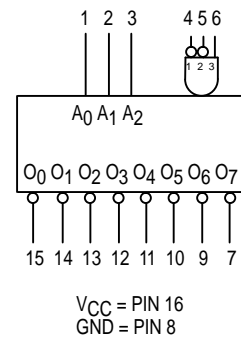

MC54/74F138

GUARANTEED OPERATING RANGES

Symbol	Parameter		Min	Typ	Max	Unit
V _{CC}	Supply Voltage	54, 74	4.5	5.0	5.5	V
T _A	Operating Ambient Temperature Range	54	-55	25	125	°C
		74	0	25	70	
I _{OH}	Output Current — High	54, 74			-1.0	mA
I _{OL}	Output Current — Low	54, 74			20	mA

DC CHARACTERISTICS OVER OPERATING TEMPERATURE RANGE (unless otherwise specified)

Symbol	Parameter	Limits			Unit	Test Conditions
		Min	Typ	Max		
V _{IH}	Input HIGH Voltage	2.0			V	Guaranteed Input HIGH Voltage
V _{IL}	Input LOW Voltage			0.8	V	Guaranteed Input LOW Voltage
V _{IK}	Input Clamp Diode Voltage			-1.2	V	V _{CC} = MIN, I _{IN} = -18 mA
V _{OH}	Output HIGH Voltage	54, 74	2.5		V	I _{OH} = -1.0 mA, V _{CC} = 4.50 V
		74	2.7		V	I _{OH} = -1.0 mA, V _{CC} = 4.75 V
V _{OL}	Output LOW Voltage			0.5	V	I _{OL} = 20 mA, V _{CC} = MIN
I _{IH}	Input HIGH Current			20	μA	V _{CC} = MAX, V _{IN} = 2.7 V
				0.1	mA	V _{CC} = MAX, V _{IN} = 7.0 V
I _{IL}	Input LOW Current			-0.6	mA	V _{CC} = MAX, V _{IN} = 0.5 V
I _{OS}	Output Short Circuit Current (Note 2)	-60		-150	mA	V _{CC} = MAX, V _{OUT} = 0 V
I _{CC}	Power Supply Current			20	mA	V _{CC} = MAX

NOTES:

- For conditions shown as MIN or MAX, use the appropriate value specified under recommended operating conditions for the applicable device type.
- Not more than one output should be shorted at a time, nor for more than 1 second.

AC CHARACTERISTICS

Symbol	Parameter	Levels of Delay	54/74F		54F		74F		Unit
			T _A = +25 °C V _{CC} = +5.0 V C _L = 50 pF		T _A = +25°C to +125°C V _{CC} = 5.0 V ±10% C _L = 50 pF		T _A = 0°C to 70°C V _{CC} = 5.0 V ±10% C _L = 50 pF		
			Min	Max	Min	Max	Min	Max	
t _{PLH}	Propagation Delay, Address to Output	3	3.0	7.5	3.0	12	3.0	8.5	ns
t _{PHL}			3.0	8.0	3.0	9.5	3.0	9.0	
t _{PLH}	Enable to Output	2	3.5	7.0	3.5	11	3.5	8.0	ns
t _{PHL}	\bar{E}_1 or \bar{E}_2		3.0	7.0	3.0	8.0	3.0	7.5	
t _{PLH}	Enable to Output	3	4.0	8.0	4.0	12.5	4.0	9.0	ns
t _{PHL}	E ₃		3.5	7.5	3.5	8.5	3.5	8.5	

FUNCTIONAL DESCRIPTION

The decoder accepts three binary weighted inputs (A₀, A₁, A₂) and when enabled provides eight mutually exclusive active LOW outputs (\bar{O}_0 – \bar{O}_7). The F138 features three Enable inputs, two active LOW (\bar{E}_1 , \bar{E}_2) and one active HIGH (E₃). All outputs will be HIGH unless \bar{E}_1 and \bar{E}_2 are LOW and E₃ is HIGH. This multiple enable function allows easy parallel

expansion of the device to a 1-of-32 (5 lines to 32 lines) decoder with just four F138s and one inverter.

The F138 can be used as an 8-output demultiplexer by using one of the active LOW Enable inputs as the data input and the other Enable inputs as strobes. The Enable inputs which are not used must be permanently tied to their appropriate active HIGH or active LOW states.

MC54/74F138

FUNCTION TABLE

Inputs						Outputs							
\bar{E}_1	\bar{E}_2	E_3	A_0	A_1	A_2	\bar{O}_0	\bar{O}_1	\bar{O}_2	\bar{O}_3	\bar{O}_4	\bar{O}_5	\bar{O}_6	\bar{O}_7
H	X	X	X	X	X	H	H	H	H	H	H	H	H
X	H	X	X	X	X	H	H	H	H	H	H	H	H
X	X	L	X	X	X	H	H	H	H	H	H	H	H
L	L	H	L	L	L	L	H	H	H	H	H	H	H
L	L	H	H	L	L	H	L	H	H	H	H	H	H
L	L	H	L	H	L	H	H	L	H	H	H	H	H
L	L	H	H	H	L	H	H	H	L	H	H	H	H
L	L	H	L	L	H	H	H	H	H	L	H	H	H
L	L	H	H	L	H	H	H	H	H	H	L	H	H
L	L	H	L	H	H	H	H	H	H	H	H	L	H
L	L	H	H	H	H	H	H	H	H	H	H	H	L

H = HIGH Voltage Level
 L = LOW Voltage Level
 X = Don't Care

