



CARRY LOOKAHEAD GENERATOR

The MC54/74F182 is a high-speed carry lookahead generator. It is generally used with the F181, F381 or 29F01 4-bit arithmetic logic unit to provide high-speed lookahead over word lengths of more than four bits.

- Provides Lookahead Carries Across a Group of Four ALUs
- Multi-level Lookahead High-speed Arithmetic Operation Over Long Word Lengths

CONNECTION DIAGRAM DIP (TOP VIEW)

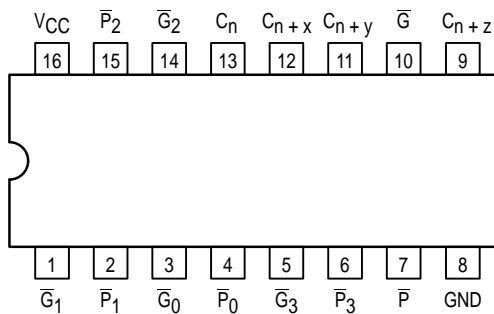

LOGIC DIAGRAM

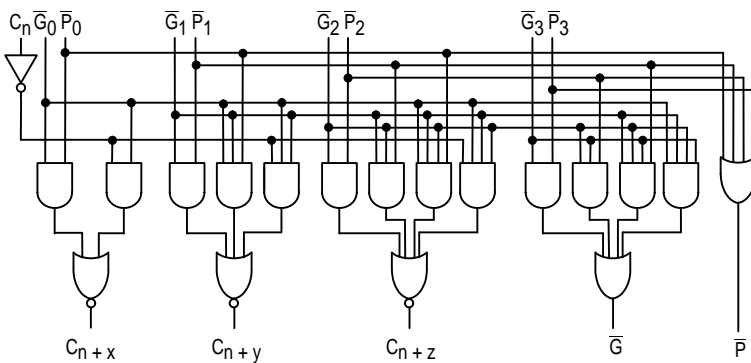

MC54/74F182

CARRY LOOKAHEAD GENERATOR

FAST™ SCHOTTKY TTL

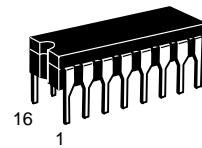

J SUFFIX
CERAMIC
CASE 620-09

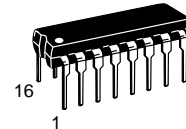

N SUFFIX
PLASTIC
CASE 648-08

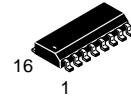

D SUFFIX
SOIC
CASE 751B-03

ORDERING INFORMATION

MC54FXXXJ	Ceramic
MC74FXXXN	Plastic
MC74FXXXD	SOIC

LOGIC SYMBOL

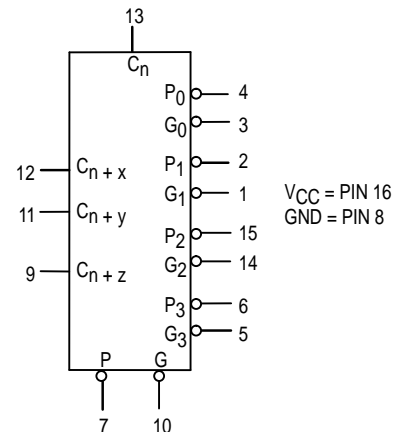

MC54/74F182

FUNCTION TABLE

Inputs									Outputs				
C _n	\overline{G}_0	\overline{P}_0	\overline{G}_1	\overline{P}_1	\overline{G}_2	\overline{P}_2	\overline{G}_3	\overline{P}_3	C _{n+x}	C _{n+y}	C _{n+z}	\overline{G}	\overline{P}
X	H	H							L				
L	H	X							L				
X	L	X							H				
H	X	L							H				
X	X	X	H	H						L			
X	H	H	H	X						L			
L	H	X	H	X						L			
X	X	X	L	X						H			
X	L	X	X	L						H			
H	X	L	X	L						H			
X	X	X	X	X	H	H					L		
X	X	X	H	H	H	X					L		
X	H	H	H	X	H	X					L		
L	H	X	H	X	H	X					L		
X	X	X	X	X	L	X					H		
X	X	X	L	X	X	L					H		
X	L	X	X	L	X	L					H		
H	X	L	X	L	X	L					H		
	X		X	X	X	X	H	H				H	
	X		X	X	H	H	H	X				H	
	X		H	H	H	X	H	X				H	
	H		H	X	H	X	H	X				H	
	X		X	X	X	X	L	X				L	
	X		X	X	L	X	X	L				L	
	X		L	X	X	L	X	L				L	
	L		X	L	X	L	X	L				L	
		H		X		X		X					H
		X		H		X		X					H
		X		X		H		X					H
		X		X		X		H					H
		L		L		L		L					L

H = HIGH Voltage Level
L = LOW Voltage Level
X = Don't Care

GUARANTEED OPERATING RANGES

Symbol	Parameter		Min	Typ	Max	Unit
V _{CC}	Supply Voltage	54,74	4.5	5.0	5.5	V
T _A	Operating Ambient Temperature Range	54	-55	25	125	°C
		74	0	25	70	
I _{OH}	Output Current — High	54, 74			-1.0	mA
I _{OL}	Output Current — Low	54, 74			20	mA

MC54/74F182

DC CHARACTERISTICS OVER OPERATING TEMPERATURE RANGE (unless otherwise specified)

Symbol	Parameter		Limits			Unit	Test Conditions	
			Min	Typ	Max			
V _{IH}	Input HIGH Voltage		2.0			V	Guaranteed Input HIGH Voltage	
V _{IL}	Input LOW Voltage				0.8	V	Guaranteed Input LOW Voltage	
V _{IK}	Input Clamp Diode Voltage				-1.2	V	I _{IN} = -18 mA	V _{CC} = MIN
V _{OH}	Output HIGH Voltage	54, 74	2.5	3.4		V	I _{OH} = -1.0 mA	V _{CC} = 4.50 V
		74	2.7	3.4		V	I _{OH} = -1.0 mA	V _{CC} = 4.75 V
V _{OL}	Output LOW Voltage			0.35	0.5	V	I _{OL} = 20 mA	V _{CC} = MIN
I _{IH}	Input HIGH Current				20	μA	V _{IN} = 2.7 V	V _{CC} = MAX
					100	μA	V _{IN} = 7.0 V	V _{CC} = MAX
I _{IL}	Input LOW Current	C _n Input			-1.2	mA	V _{IN} = 0.5 V	V _{CC} = MAX
		\overline{P}_3 Input			-2.4			
		\overline{P}_2 Input			-3.6			
		$\overline{G}_3, \overline{P}_0, \overline{P}_1$ Inputs			-4.8			
		$\overline{G}_0, \overline{G}_2$ Inputs			-8.4			
		\overline{G}_1 Input			-9.6			
I _{OS}	Output Short Circuit Current (Note 2)		-60		-150	mA	V _{OUT} = 0 V	V _{CC} = MAX
I _{CCH}	Power Supply Current (All Outputs HIGH)			18.4	28	mA	$\overline{P}_3, \overline{G}_3 = 4.5 V$ All Other Inputs = GND	V _{CC} = MAX
I _{CCL}	Power Supply Current (All Outputs LOW)			23.5	36	mA	$\overline{G}_0, \overline{G}_1, \overline{G}_2 = 4.5 V$ All Other Inputs = GND	V _{CC} = MAX

NOTES:

- For conditions shown as MIN or MAX, use the appropriate value specified under guaranteed operating ranges.
- No more than one output should be shorted at a time, nor for more than 1 second.

AC CHARACTERISTICS

Symbol	Parameter	54/74F			54F		74F		Unit
		T _A = +25°C			T _A = -55°C to +125°C		T _A = 0°C to +70°C		
		Min	Typ	Max	Min	Max	Min	Max	
t _{PLH}	Propagation Delay	3.0	6.6	8.5	3.0	10.5	3.0	9.5	ns
t _{PHL}	C _n to C _{n+x} , C _{n+y} , C _{n+z}	3.0	6.8	9.0	3.0	11	3.0	10	
t _{PLH}	Propagation Delay	2.5	6.2	8.0	2.5	10.7	2.5	9.0	ns
t _{PHL}	$\overline{P}_0, \overline{P}_1, \text{ or } \overline{P}_2$ to C _{n+x} , C _{n+y} , C _{n+z}	1.5	3.7	5.0	1.5	6.5	1.5	6.0	
t _{PLH}	Propagation Delay	2.5	6.5	8.5	2.5	10.5	2.5	9.5	ns
t _{PHL}	$\overline{G}_0, \overline{G}_1, \text{ or } \overline{G}_2$ to C _{n+x} , C _{n+y} , C _{n+z}	1.5	3.9	5.2	1.5	6.5	1.5	6.0	

MC54/74F182

AC CHARACTERISTICS (Continued)

Symbol	Parameter	54/74F			54F		74F		Unit
		T _A = +25°C V _{CC} = +5.0 V C _L = 50 pF			T _A = -55°C to +125°C V _{CC} = 5.0 V ± 10% C _L = 50 pF		T _A = 0°C to +70°C V _{CC} = 5.0V ± 10% C _L = 50 pF		
		Min	Typ	Max	Min	Max	Min	Max	
t _{PLH}	Propagation Delay	2.0	7.9	10	2.0	12.5	2.0	11	ns
t _{PHL}	$\bar{P}_1, \bar{P}_2, \text{ or } \bar{P}_3 \text{ to } \bar{G}$	2.0	6.0	8.0	2.0	9.5	2.0	9.0	
t _{PLH}	Propagation Delay	2.0	8.3	10.5	2.0	12.5	2.0	11.5	ns
t _{PHL}	$\bar{G}_n \text{ to } \bar{G}$	1.5	5.7	7.5	1.5	9.5	1.5	8.5	
t _{PLH}	Propagation Delay	2.5	5.7	7.5	2.5	11	2.5	8.5	ns
t _{PHL}	$\bar{P}_n \text{ to } \bar{P}$	2.5	4.1	5.5	2.5	7.5	2.5	6.5	

FUNCTIONAL DESCRIPTION

The F182 carry lookahead generator accepts up to four pairs of active-LOW Carry Propagate (\bar{P}_0 - \bar{P}_3) and carry Generate (\bar{G}_0 - \bar{G}_3) signals and an active-HIGH Carry input (C_n) and provides anticipated active-HIGH carries ($C_{n+x}, C_{n+y}, C_{n+z}$) across four groups of binary adders. The F182 also has active-LOW Carry Propagate (\bar{P}) and Carry Generate (\bar{G}) outputs which may be used for further levels of lookahead. The logic equations provided at the output are:

$$C_{n+x} = G_0 + P_0 C_n$$

$$C_{n+y} = G_1 + P_1 G_0 + P_1 P_0 C_n$$

$$C_{n+z} = G_2 + P_2 G_1 + P_2 P_1 G_0 + P_2 P_1 P_0 C_n$$

$$\bar{G} = \bar{G}_3 + P_3 \bar{G}_2 + P_3 P_2 \bar{G}_1 + P_3 P_2 P_1 \bar{G}_0$$

$$\bar{P} = \bar{P}_3 P_2 P_1 P_0$$

Also, the F182 can be used with binary ALUs in an active-LOW or active-HIGH input operand mode. The connections (Figure 1) to and from the ALU to the carry lookahead generator are identical in both cases. Carries are rippled between lookahead blocks. The critical speed path follows the circled numbers. There are several possible arrangements for the carry interconnects, but all achieve about the same speed. A 28-bit ALU is formed by dropping the last F181 or F381.

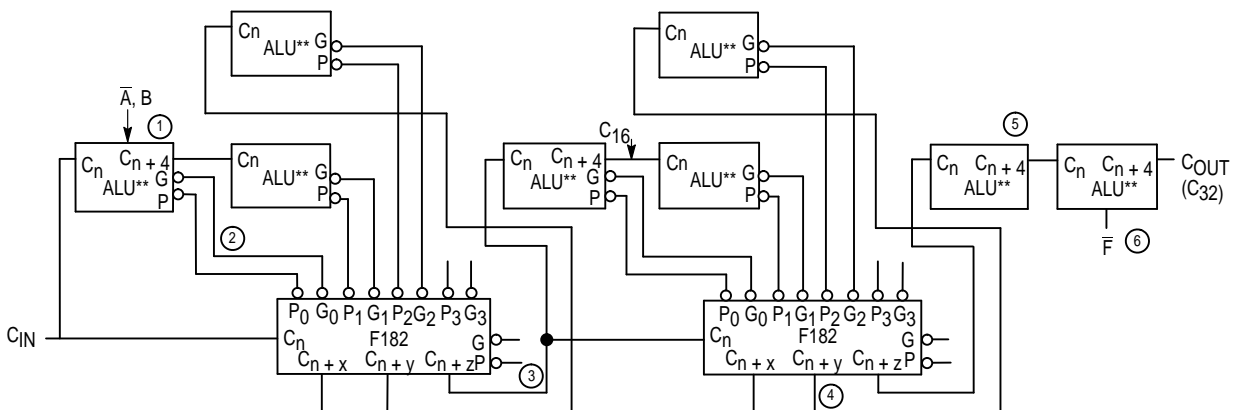

** ALUs may be either F181, F381, or 2901A.

Figure 1. 32-Bit ALU with Ripple Carry Between 16-Bit Lookahead ALUs