

**For:char**

**Printed on:Mon, Feb 6, 1995 09:49:45**

**From book:DL121CH4 (5) VIEW**

**Document:MC74F381 (5) VIEW**

**Last saved on:Fri, Feb 3, 1995 16:06:52**



# 4-BIT ARITHMETIC LOGIC UNIT

The MC54/74F381 performs three arithmetic and three logic operations on two 4-bit words, A and B. Two additional Select input codes force the Function outputs LOW or HIGH. Carry Propagate and Generate outputs are provided for use with the F182 Carry Lookahead Generator for high-speed expansion to longer word lengths. For ripple expansion, refer to the F382 ALU data sheet.

- Low Input Loading Minimizes Drive Requirements
- Performs Six Arithmetic and Logic Functions
- Selectable Low (Clear) and High (Preset) Functions
- Carry Generate and Propagate Outputs for use with Carry Lookahead Generator

### CONNECTION DIAGRAM

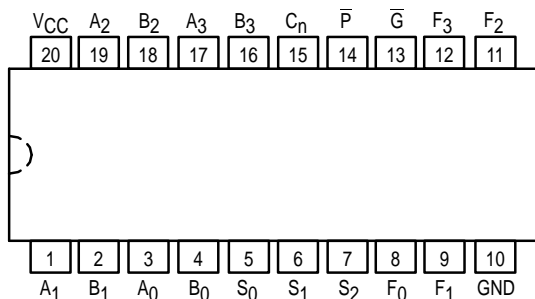

### LOGIC SYMBOL

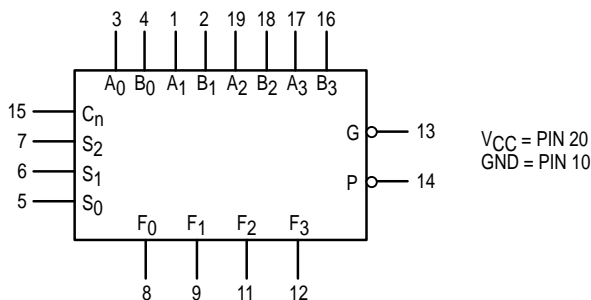

VCC = PIN 20  
GND = PIN 10

## MC54/74F381

4-BIT ARITHMETIC LOGIC UNIT  
FAST™ SCHOTTKY TTL

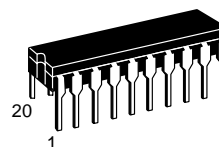

J SUFFIX  
CERAMIC  
CASE 732-03

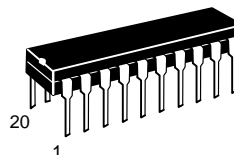

N SUFFIX  
PLASTIC  
CASE 738-03

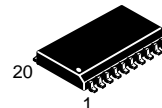

DW SUFFIX  
SOIC  
CASE 751D-03

### ORDERING INFORMATION

MC54FXXXJ Ceramic  
MC74FXXXN Plastic  
MC74FXXXDW SOIC

### GUARANTEED OPERATING RANGES

Symbol	Parameter		Min	Typ	Max	Unit
VCC	Supply Voltage	54, 74	4.5	5.0	5.5	V
TA	Operating Ambient Temperature Range	54	-55	25	125	°C
		74	0	25	70	
IOH	Output Current — High	54, 74			-1.0	mA
IOL	Output Current — Low	54, 74			20	mA

# MC54/74F381

## LOGIC DIAGRAM

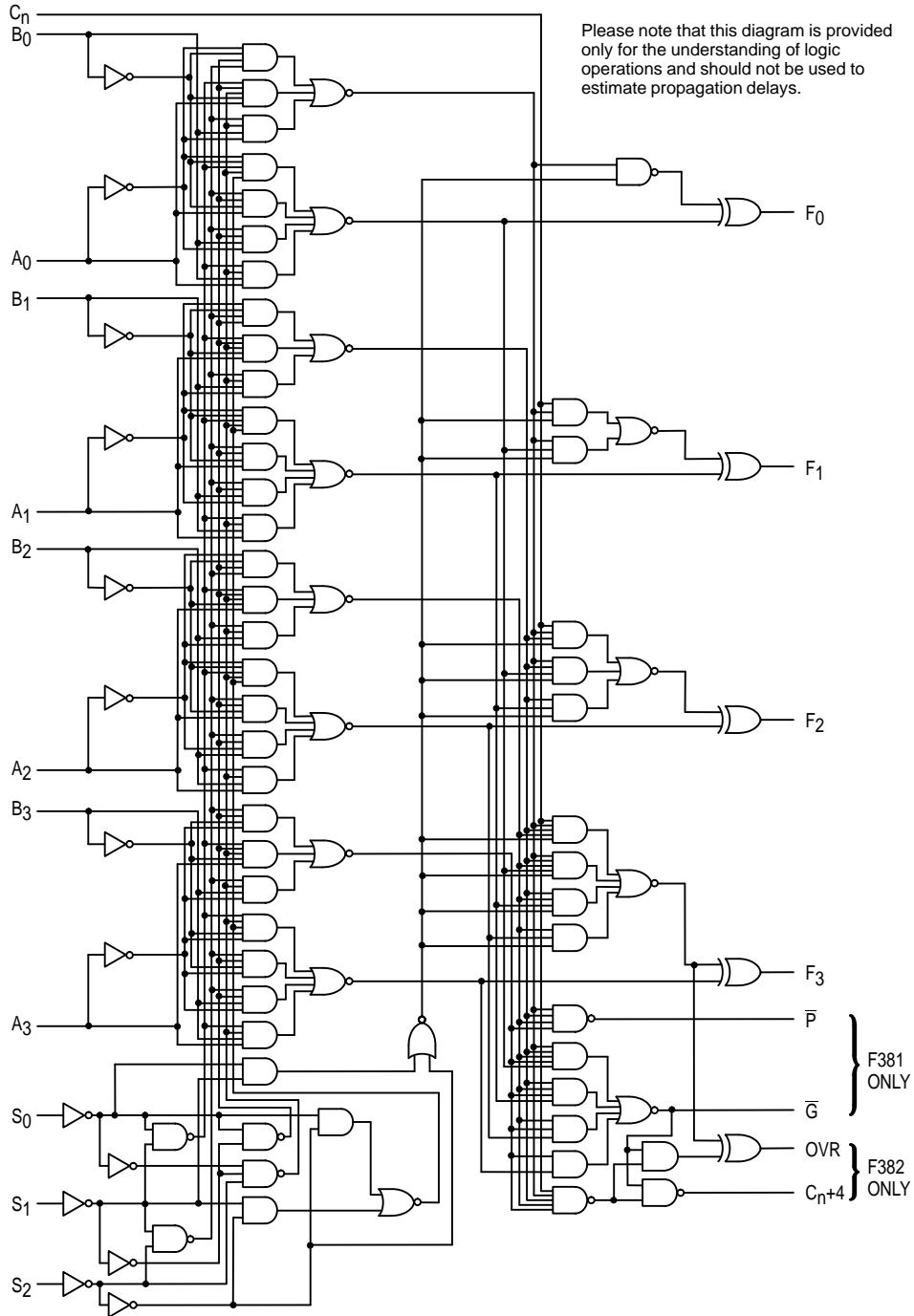

# MC54/74F381

## DC CHARACTERISTICS OVER OPERATING TEMPERATURE RANGE (unless otherwise specified)

Symbol	Parameter	Limits			Unit	Test Conditions	
		Min	Typ	Max			
$V_{IH}$	Input HIGH Voltage	2.0			V	Guaranteed Input HIGH Voltage	
$V_{IL}$	Input LOW Voltage			0.8	V	Guaranteed Input LOW Voltage	
$V_{IK}$	Input Clamp Diode Voltage			-1.2	V	$I_{IN} = -18 \text{ mA}$	$V_{CC} = \text{MIN}$
$V_{OH}$	Output HIGH Voltage	54, 74	2.5	3.4	V	$I_{OH} = -1.0 \text{ mA}$	$V_{CC} = 4.5 \text{ V}$
		74	2.7	3.4	V	$I_{OH} = -1.0 \text{ mA}$	$V_{CC} = 4.75 \text{ V}$
$V_{OL}$	Output LOW Voltage		0.35	0.5	V	$I_{OL} = 20 \text{ mA}$	$V_{CC} = \text{MIN}$
$I_{IH}$	Input HIGH Current			20	$\mu\text{A}$	$V_{IN} = 2.7 \text{ V}$	$V_{CC} = \text{MAX}$
				100	$\mu\text{A}$	$V_{IN} = 7.0 \text{ V}$	
$I_{IL}$	Input LOW Current $S_0$ - $S_2$ Inputs			-0.6	mA	$V_{IN} = 0.5 \text{ V}$	$V_{CC} = \text{MAX}$
	Other Inputs			-2.4	mA	$V_{IN} = 0.5 \text{ V}$	
$I_{OS}$	Output Short Circuit Current (Note 2)	-60		-150	mA	$V_{OUT} = 0 \text{ V}$	$V_{CC} = \text{MAX}$
$I_{CC}$	Power Supply Current		59	89	mA	$S_0$ - $S_2 = \text{GND};$ Other Inputs HIGH	$V_{CC} = \text{MAX}$

### NOTES:

1. For conditions such as MIN or MAX, use the appropriate value specified under guaranteed operating ranges.
2. Not more than one output should be shorted at a time, nor for more than 1 second.

## FUNCTIONAL DESCRIPTION

Signals applied to the Select inputs  $S_0$ - $S_2$  determine the mode of operation, as indicated in the Function Select Table. An extensive listing of input and output levels is shown in the Truth Table. The circuit performs the arithmetic functions for either active-HIGH or active-LOW operands, with output levels in the same convention. In the Subtract operating modes, it is necessary to force a carry (HIGH for active-HIGH oper-

ands, LOW for active-LOW operands) into the  $C_n$  input of the least significant package.

The Carry Generate ( $\overline{G}$ ) and Carry Propagate ( $\overline{P}$ ) outputs supply input signals to the F182 carry lookahead generator for expansion to longer word length, as shown in Figure 1. Note that an F382 ALU is used for the most significant package. Typical delays for Figure 1 are given in Figure 2.

FUNCTION SELECT TABLE

Select			Operation
$S_0$	$S_1$	$S_2$	
L	L	L	Clear
H	L	L	B Minus A
L	H	L	A Minus B
H	H	L	A Plus B
L	L	H	$A \oplus B$
H	L	H	$A + B$
L	H	H	$AB$
H	H	H	Preset

H = HIGH Voltage Level

L = LOW Voltage Level

# MC54/74F381

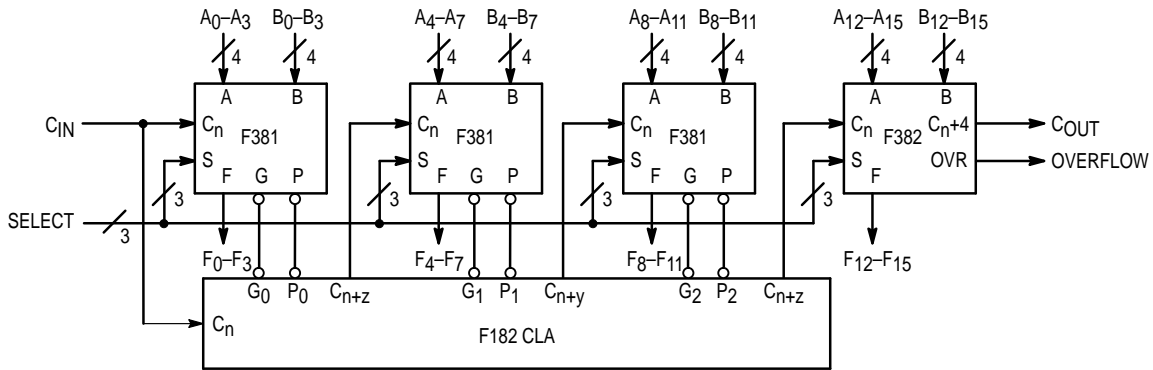

Figure 1. 16-Bit Lookahead Carry ALU Expansion

Path Segment	Toward F	Output $C_n + 4, OVR$
$A_i$ or $B_i$ to P	7.2 ns	7.2 ns
$P_i$ to $C_{n+j}$ ('F182)	6.2 ns	6.2 ns
$C_n$ to F	8.1 ns	—
$C_n$ to $C_{n+4}, OVR$	—	8.0 ns
Total Delay	21.5 ns	21.4 ns

Figure 2. 16-Bit Delay Tabulation

## AC CHARACTERISTICS

Symbol	Parameter	54/74F			54F		74F		Unit
		$T_A = +25^\circ\text{C}$ $V_{CC} = +5.0\text{ V}$ $C_L = 50\text{ pF}$			$T_A = -55\text{ to }+125^\circ\text{C}$ $V_{CC} = 5.0\text{ V } \pm 10\%$ $C_L = 50\text{ pF}$		$T_A = 0\text{ to }+70^\circ\text{C}$ $V_{CC} = 5.0\text{ V } \pm 10\%$ $C_L = 50\text{ pF}$		
		Min	Typ	Max	Min	Max	Min	Max	
$t_{PLH}$ $t_{PHL}$	Propagation Delay $C_n$ to $F_i$	2.5 2.5	8.1 5.7	12 8.0	2.5 2.5	15 11	2.5 2.5	13 9.0	ns
$t_{PLH}$ $t_{PHL}$	Propagation Delay Any A or B to Any F	4.0 3.5	10.4 8.2	15 11	4.0 3.5	18 14	4.0 3.5	16 12	ns
$t_{PLH}$ $t_{PHL}$	Propagation $S_i$ to $F_i$	4.5 4.0	8.3 8.2	20 13	4.5 4.0	23.5 16	4.5 4.0	21.5 14	ns
$t_{PLH}$ $t_{PHL}$	Propagation Delay $A_i$ or $B_i$ to $\bar{G}$	3.0 4.0	6.4 6.8	9.0 10	3.0 4.0	12 13	3.0 4.0	10 11	ns
$t_{PLH}$ $t_{PHL}$	Propagation Delay $A_i$ or $B_i$ to $\bar{P}$	2.5 3.5	7.2 6.5	10.5 9.5	2.5 3.5	13.5 12.5	2.5 3.5	11.5 10.5	ns
$t_{PLH}$ $t_{PHL}$	Propagation Delay $S_i$ to $\bar{G}$ or $\bar{P}$	4.0 4.5	7.8 10.2	12 13.5	4.0 4.5	15 16.5	4.0 4.5	13 14.5	ns

# MC54/74F381

TRUTH TABLE

FUNCTION	INPUTS						OUTPUTS								
	S <sub>0</sub>	S <sub>1</sub>	S <sub>2</sub>	C <sub>n</sub>	A <sub>n</sub>	B <sub>n</sub>	F <sub>0</sub>	F <sub>1</sub>	F <sub>2</sub>	F <sub>3</sub>	$\overline{G}$	P			
CLEAR	0	0	0	X	X	X	0	0	0	0	0	0			
B MINUS A	1	0	0	0	0	0	1	1	1	1	1	0			
				0	0	1	0	1	1	1	0	0			
				0	1	0	0	0	0	1	1	1	1		
				0	1	1	1	1	1	1	1	1	0		
				1	0	0	0	0	0	0	0	0	1	0	
				1	0	1	1	1	1	1	1	1	0	0	
				1	1	0	0	0	0	1	0	0	0	1	1
A MINUS B	0	1	0	0	0	0	1	1	1	1	1	0			
				0	0	1	0	0	0	0	0	1	1		
				0	1	0	0	1	1	1	1	1	0	0	
				0	1	1	1	1	1	1	1	1	1	0	
				1	0	0	0	0	0	0	0	0	1	0	
				1	0	1	1	1	1	1	0	0	0	1	1
				1	1	0	0	0	0	1	1	1	1	0	0
A PLUS B	1	1	0	0	0	0	0	0	0	0	0	1			
				0	0	1	1	1	1	1	1	1	0		
				0	1	0	0	1	1	1	1	1	1	0	
				0	1	1	1	0	1	1	1	0	0	0	
				1	0	0	0	1	0	0	0	0	1	1	
				1	0	1	1	0	0	0	0	0	1	0	
				1	1	0	0	0	0	0	0	0	1	0	
A⊕B	0	0	1	X	0	0	0	0	0	0	0	0			
				X	0	1	1	1	1	1	1	1	1		
				X	1	0	1	1	1	1	1	1	0		
				X	1	1	1	0	0	0	0	0	0		
A+B	1	0	1	X	0	0	0	0	0	0	0	0			
				X	0	1	1	1	1	1	1	1	1		
				X	1	0	1	1	1	1	1	1	1		
				X	1	1	1	1	1	1	1	1	0		
AB	0	1	1	X	0	0	0	0	0	0	0	0			
				X	0	1	1	0	0	0	0	1	1		
				X	1	0	0	0	0	0	0	0	0		
				X	1	1	1	1	1	1	1	1	0		
PRESET	1	1	1	X	0	0	0	1	1	1	1	1			
				X	0	1	1	1	1	1	1	1	1		
				X	1	0	1	1	1	1	1	1	1		
				X	1	1	1	1	1	1	1	1	0		

1 = HIGH Voltage Level  
 0 = LOW Voltage Level  
 X = Immaterial