



# OCTAL D-TYPE FLIP-FLOP WITH 3-STATE OUTPUTS

The MC54/74F534 is a high-speed, low-power octal D-type flip-flop featuring separate D-type inputs for each flip-flop and 3-state outputs for bus oriented applications. A buffered Clock (CP) and Output Enable ( $\overline{OE}$ ) are common to all flip-flops. The F534 is the same as the F374 except that the outputs are inverted.

- Edge-Triggered D-Type Inputs
- Buffered Positive Edge-Triggered Clock
- 3-State Outputs for Bus Oriented Applications

### CONNECTION DIAGRAM

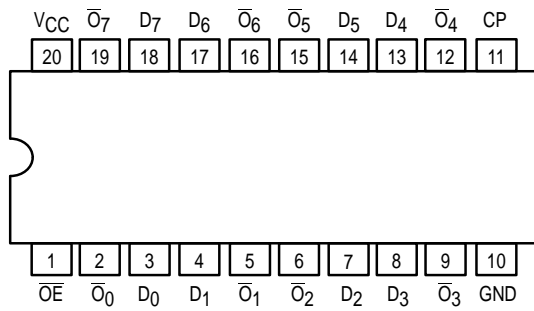

### LOGIC SYMBOL

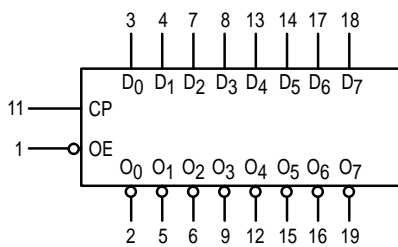

$V_{CC}$  = PIN 20  
GND = PIN 10

## MC54/74F534

### OCTAL D-TYPE FLIP-FLOP WITH 3-STATE OUTPUTS

FAST™ SCHOTTKY TTL

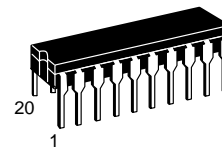

**J SUFFIX**  
CERAMIC  
CASE 732-03

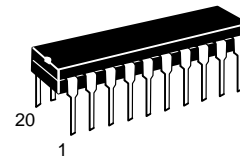

**N SUFFIX**  
PLASTIC  
CASE 738-03

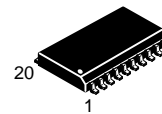

**DW SUFFIX**  
SOIC  
CASE 751D-03

### ORDERING INFORMATION

MC54FXXXJ Ceramic  
MC74FXXXN Plastic  
MC74FXXXDW SOIC

### GUARANTEED OPERATING RANGES

Symbol	Parameter	Min	Typ	Max	Unit	
$V_{CC}$	Supply Voltage	54, 74	4.5	5.0	5.5	V
$T_A$	Operating Ambient Temperature Range	54	-55	25	125	°C
		74	0	25	70	
$I_{OH}$	Output Current — High	54, 74			-3.0	mA
$I_{OL}$	Output Current — Low	54, 74			24	mA

# MC54/74F534

## LOGIC DIAGRAM

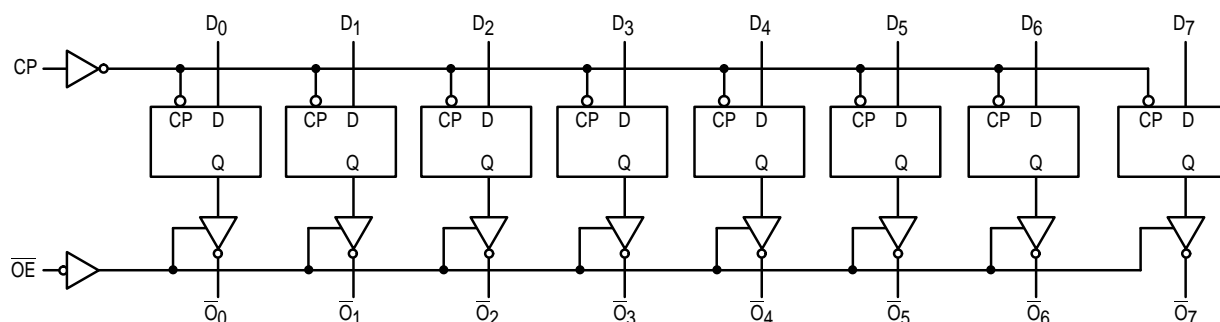

Please note that this diagram is provided only for the understanding of logic operations and should not be used to estimate propagation delays.

## FUNCTIONAL DESCRIPTION

The F534 consists of eight edge-triggered flip-flops with individual D-type inputs and 3-state true outputs. The buffered clock and buffered Output Enable are common to all flip-flops. The eight flip-flops will store the state of their individual D inputs that meet the setup and hold times requirements on the

LOW-to-HIGH Clock (CP) transition. With the Output Enable ( $\overline{OE}$ ) LOW, the contents of the eight flip-flops are available at the outputs. When the  $\overline{OE}$  is HIGH, the outputs go to the high impedance state. Operation of the  $\overline{OE}$  input does not affect the state of the flip-flops.

## DC CHARACTERISTICS OVER OPERATING TEMPERATURE RANGE (unless otherwise specified)

Symbol	Parameter	Limits			Unit	Test Conditions	
		Min	Typ	Max			
$V_{IH}$	Input HIGH Voltage	2.0			V	Guaranteed Input HIGH Voltage	
$V_{IL}$	Input LOW Voltage			0.8	V	Guaranteed Input LOW Voltage	
$V_{IK}$	Input Clamp Diode Voltage			-1.2	V	$I_{IN} = -18 \text{ mA}$	$V_{CC} = \text{MIN}$
$V_{OH}$	Output HIGH Voltage	54, 74	2.4	3.3	V	$I_{OH} = -3.0 \text{ mA}$	$V_{CC} = 4.5 \text{ V}$
		74	2.7	3.3	V	$I_{OH} = -3.0 \text{ mA}$	$V_{CC} = 4.75 \text{ V}$
$V_{OL}$	Output LOW Voltage		0.35	0.5	V	$I_{OL} = 24 \text{ mA}$	$V_{CC} = \text{MIN}$
$I_{OZH}$	Output OFF Current — HIGH			50	$\mu\text{A}$	$V_{OUT} = 2.7 \text{ V}$	$V_{CC} = \text{MAX}$
$I_{OZL}$	Output OFF Current — LOW			-50	$\mu\text{A}$	$V_{OUT} = 0.5 \text{ V}$	$V_{CC} = \text{MAX}$
$I_{IH}$	Input HIGH Current			20	$\mu\text{A}$	$V_{IN} = 2.7 \text{ V}$	$V_{CC} = \text{MAX}$
				100		$V_{IN} = 7.0 \text{ V}$	
$I_{IL}$	Input LOW Current			-0.6	$\text{mA}$	$V_{IN} = 0.5 \text{ V}$	$V_{CC} = \text{MAX}$
$I_{OS}$	Output Short Circuit Current (Note 2)	-60		-150	$\text{mA}$	$V_{OUT} = 0 \text{ V}$	$V_{CC} = \text{MAX}$
$I_{CCZ}$	Power Supply Current		55	86	$\text{mA}$	$D_n = \text{Gnd}$ $\overline{OE} = 4.5 \text{ V}$	$V_{CC} = \text{MAX}$

### NOTES:

- For conditions such as MIN or MAX, use the appropriate value specified under guaranteed operating ranges.
- Not more than one output should be shorted at a time, nor for more than 1 second.

# MC54/74F534

## AC CHARACTERISTICS

Symbol	Parameter	54/74F			54F		74F		Unit
		T <sub>A</sub> = +25°C V <sub>CC</sub> = +5.0 V C <sub>L</sub> = 50 pF			T <sub>A</sub> = -55 to +125°C V <sub>CC</sub> = 5.0 V ±10% C <sub>L</sub> = 50 pF		T <sub>A</sub> = 0 to +70°C V <sub>CC</sub> = 5.0 V ±10% C <sub>L</sub> = 50 pF		
		Min	Typ	Max	Min	Max	Min	Max	
f <sub>max</sub>	Maximum Clock Frequency	100			60		70		MHz
t <sub>PLH</sub> t <sub>PHL</sub>	Propagation Delay CP to $\bar{O}_n$	4.0 4.0	6.5 6.5	8.5 8.5	4.0 4.0	10.5 11	4.0 4.0	10 10	ns
t <sub>PZH</sub> t <sub>PZL</sub>	Output Enable Time	2.0 2.0	9.0 5.8	11.5 7.5	2.0 2.0	14 10	2.0 2.0	12.5 8.5	ns
t <sub>PHZ</sub> t <sub>PLZ</sub>	Output Disable Time	2.0 2.0	5.3 4.3	7.0 5.5	2.0 2.0	8.0 7.5	2.0 2.0	8.0 6.5	

## AC OPERATING REQUIREMENTS

Symbol	Parameter	54/74F			54F		74F		Unit
		T <sub>A</sub> = +25°C V <sub>CC</sub> = +5.0 V			T <sub>A</sub> = -55 to +125°C V <sub>CC</sub> = 5.0 V ±10%		T <sub>A</sub> = 0 to +70°C V <sub>CC</sub> = 5.0 V ±10%		
		Min	Typ	Max	Min	Max	Min	Max	
t <sub>S</sub> (H) t <sub>S</sub> (L)	Setup Time, HIGH or LOW D <sub>n</sub> to CP	2.0 2.0			2.5 2.0		2.0 2.0		ns
t <sub>H</sub> (H) t <sub>H</sub> (L)	Hold Time, HIGH or LOW D <sub>n</sub> to CP	2.0 2.0			2.0 2.5		2.0 2.0		
t <sub>w</sub> (H) t <sub>w</sub> (L)	CP Pulse Width HIGH or LOW	7.0 6.0			7.0 6.0		7.0 6.0		ns