



DUAL 1-OF-4 DECODER WITH 3-STATE OUTPUTS

The MC54/74F539 contains two independent decoders. Each accepts two Address (A_0 – A_1) input signals and decodes them to select one of four mutually exclusive outputs. A polarity control input (P) determines whether the outputs are active HIGH ($P = L$) or active LOW ($P = H$). An active LOW input Enable (\bar{E}) is available for data demultiplexing; data is routed to the selected output in non-inverted form in the active LOW mode or in inverted form in the active HIGH mode. A HIGH Signal on the active LOW Output Enable (\bar{OE}) input forces the 3-state outputs to the high impedance state.

- Demultiplexing Capability
- 3-State Outputs
- Two Completely Independent 1-of-4 Decoders
- Input Clamp Diodes Limit High Speed Termination Effects
- ESD Protection > 4000 Volts

CONNECTION DIAGRAM DIP (TOP VIEW)

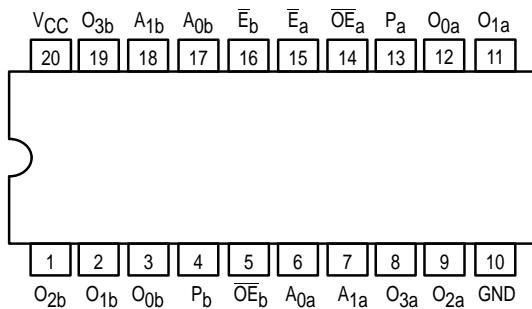

LOGIC DIAGRAM (1/2 SHOWN)

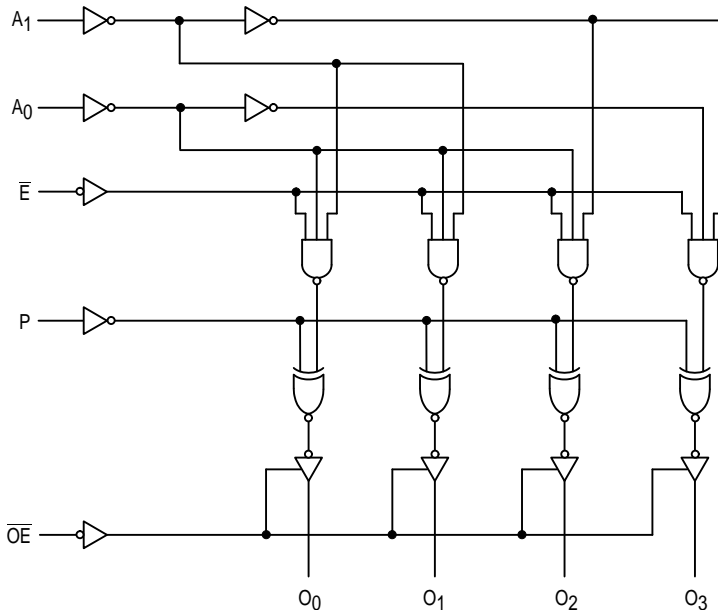

Please note that this diagram is provided only for the understanding of logic operations and should not be used to estimate propagation delays.

MC54/74F539

DUAL 1-OF-4 DECODER WITH 3-STATE OUTPUTS

FAST™ SCHOTTKY TTL

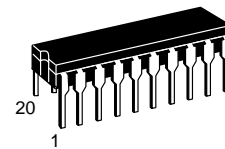

J SUFFIX
CERAMIC
CASE 732-03

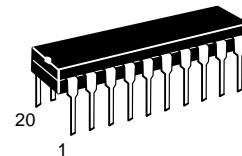

N SUFFIX
PLASTIC
CASE 738-03

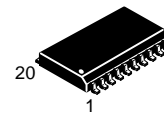

DW SUFFIX
SOIC
CASE 751D-03

ORDERING INFORMATION

MC54FXXXJ	Ceramic
MC74FXXXN	Plastic
MC74FXXXDW	SOIC

LOGIC SYMBOL

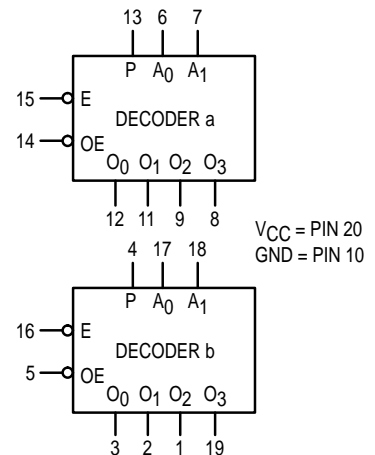

MC54/74F539

GUARANTEED OPERATING RANGES

Symbol	Parameter	Min	Typ	Max	Unit	
V _{CC}	Supply Voltage	54, 74	4.5	5.0	5.5	V
T _A	Operating Ambient Temperature Range	54	-55	25	125	°C
		74	0	25	70	
I _{OH}	Output Current — High	54, 74			-3.0	mA
I _{OL}	Output Current — Low	54, 74			24	mA

DC CHARACTERISTICS OVER OPERATING TEMPERATURE RANGE (unless otherwise specified)

Symbol	Parameter	Limits			Unit	Test Conditions
		Min	Typ	Max		
V _{IH}	Input HIGH Voltage	2.0			V	Guaranteed Input HIGH Voltage
V _{IL}	Input LOW Voltage			0.8	V	Guaranteed Input LOW Voltage
V _{IK}	Input Clamp Diode Voltage			-1.2	V	V _{CC} = MIN, I _{IN} = -18 mA
V _{OH}	Output HIGH Voltage	54, 74	2.4		V	I _{OH} = -3.0 mA, V _{CC} = 4.5 V
		74	2.7		V	I _{OH} = -3.0 mA, V _{CC} = 4.75 V
V _{OL}	Output LOW Voltage			0.5	V	I _{OL} = 24 mA, V _{CC} = MIN
I _{OZH}	Output OFF Current — HIGH			50	μA	V _{OUT} = 2.7 V, V _{CC} = MAX
I _{OZL}	Output OFF Current — LOW			-50	μA	V _{OUT} = 0.5 V, V _{CC} = MAX
I _{IH}	Input HIGH Current			20	μA	V _{CC} = MAX, V _{IN} = 2.7 V
				0.1	mA	V _{CC} = MAX, V _{IN} = 7.0 V
I _{IL}	Input LOW Current			-0.6	mA	V _{CC} = MAX, V _{IN} = 0.5 V
I _{OS}	Output Short Circuit Current (Note 2)	-60		-150	mA	V _{CC} = MAX, V _{OUT} = 0 V
I _{CCZ}	Power Supply Current		40	60	mA	V _{CC} = MAX, A ₀ , A ₁ , \bar{E} = GND OE, P = HIGH

AC CHARACTERISTICS

Symbol	Parameter	54/74F			54F		74F		Unit
		T _A = +25°C V _{CC} = +5.0 V C _L = 50 pF			T _A = -55 to +125°C V _{CC} = 5.0 V ± 10% C _L = 50 pF		T _A = 0 to 70°C V _{CC} = 5.0 V ± 10% C _L = 50 pF		
		Min	Typ	Max	Min	Max	Min	Max	
t _{PLH} t _{PHL}	Propagation Delay A _n to O _n	3.5 3.0		12.5 12.5	3.0 2.5	18.5 16	3.0 2.5	13.5 13	ns
t _{PLH} t _{PHL}	Propagation Delay E to O _n	3.0 3.0		11 11	2.5 3.0	14 13.5	3.0 3.0	12 11.5	ns
t _{PLH} t _{PHL}	Propagation Delay P to O _n	4.0 3.5		9.5 9.5	3.5 3.0	12.5 11.5	3.5 3.0	10.5 10	ns
t _{PLH} t _{PHL}	Propagation Delay P to \bar{O}_n	5.0 3.0		14.5 9.0	4.0 3.0	19.5 11.5	4.0 3.0	15.5 9.5	ns
t _{PZH} t _{PZL}	Output Enable Time \bar{OE} to O _n	2.5 4.0		7.5 10	2.0 3.5	10.5 13.5	2.0 3.5	8.5 11.5	ns
t _{PHZ} t _{PLZ}	Output Disable Time \bar{OE} to O _n	1.5 2.0		6.0 8.0	1.0 1.5	7.5 9.5	1.0 1.5	6.5 8.5	

MC54/74F539

TRUTH TABLE (each half)

Function	Inputs				Outputs			
	\overline{OE}	\overline{E}	A ₁	A ₀	O ₀	O ₁	O ₂	O ₃
High Impedance	H	X	X	X	Z	Z	Z	Z
Disable	L	H	X	X	O _n = P			
Active HIGH Output (P = L)	L	L	L	L	H	L	L	L
	L	L	L	H	L	H	L	L
	L	L	H	L	L	L	H	L
	L	L	H	H	L	L	L	H
Active LOW Output (P = H)	L	L	L	L	L	H	H	H
	L	L	L	H	H	L	H	H
	L	L	H	L	H	H	L	H
	L	L	H	H	H	H	H	L

H = HIGH Voltage Level
 L = LOW Voltage Level
 X = Don't Care
 Z = High Impedance