



MOTOROLA

SEMICONDUCTORS

3501 ED BLUESTEIN BLVD., AUSTIN, TEXAS 78721

MC14419

2-OF-8 KEYPAD-TO-BINARY ENCODER

The MC14419 is designed for phone dialer system applications, but finds many applications as a keypad-to-binary encoder. The device contains a 2-of-8 to binary encoder, a strobe generator, and an illegal state detector. The encoder has four row inputs and four column inputs, and is designed to accept inputs from 16 keyswitches arranged in a 4x4 matrix. For an output on the four data lines, one and only one row along with one and only one column input line must be activated. All other combinations are suppressed by the illegal state detector to eliminate false data output.

The strobe generator produces a strobe pulse when any of the 10 keys corresponding to numerals 0 through 9 are depressed. The strobe output can be used to eliminate erroneous data entry due to contact bounce. For a strobe output to occur, the key row and column input lines must remain stable for 80 clock pulses after activation. When the contact bounce has settled and 80 clock pulses have occurred, the output will be a single strobe pulse equal in width to that of the clock low state. The strobe generator will output one and only one pulse each time a numerical key is depressed. After the pulse has occurred, noise and bounce due to contact break will not cause another strobe pulse. With a 16 kHz input clock frequency, the pulse occurs 5 ms after the last bounce.

- Suppressed Output for Illegal Input Codes
- On-Chip Pullup Resistors for Row and Column Inputs
- Clock Input Conditioning Circuit
- Low Current Drain in Standby Mode
5.0µA Typical @ 5.0 Vdc
- Subsystem Complement to the MC14403/14409 Phone Pulse Converter
- Codes for Numbers 0-9 Produce a Strobe Pulse
- One Key Rollover Feature

CMOS

(LOW-POWER COMPLEMENTARY MOS)

2-OF-8 KEYPAD-TO-BINARY ENCODER

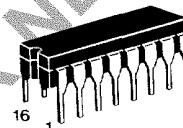

L SUFFIX
CERAMIC PACKAGE
CASE 620

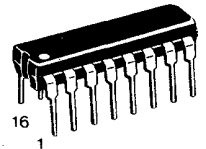

P SUFFIX
PLASTIC PACKAGE
CASE 648

ORDERING INFORMATION

MC14XXX

Suffix Denotes
 — L = Ceramic
 — P = Plastic

PIN ASSIGNMENT

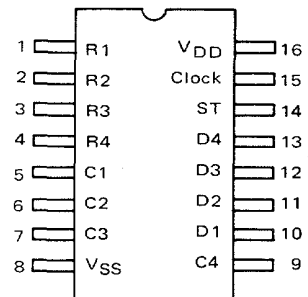

BLOCK DIAGRAM

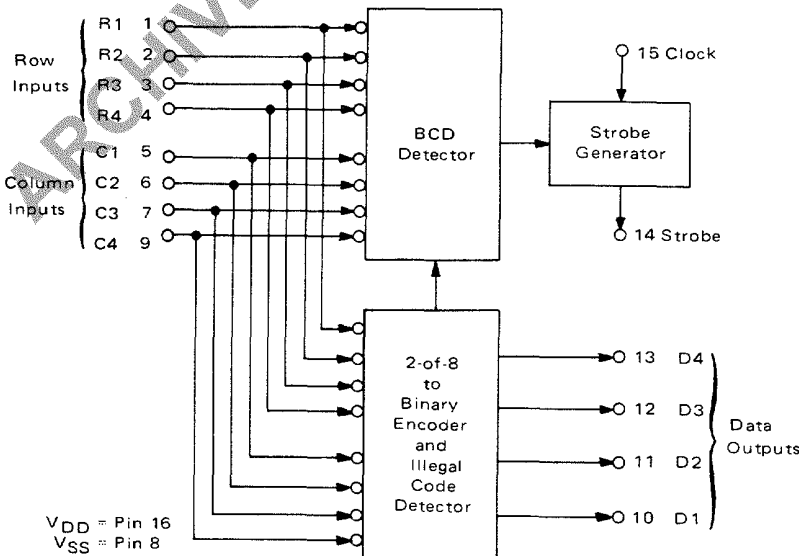

This device contains circuitry to protect the inputs against damage due to high static voltages or electric fields; however, it is advised that normal precautions be taken to avoid application of any voltage higher than maximum rated voltages to this high impedance circuit. For proper operation it is recommended that V_{in} and V_{out} be constrained to the range $V_{SS} \leq (V_{in} \text{ or } V_{out}) \leq V_{DD}$.

MAXIMUM RATINGS (Voltages referenced to V_{SS} , Pin 8.)

Rating	Symbol	Value	Unit
DC Supply Voltage	V_{DD}	+6.0 to -0.5	Vdc
Input Voltage, All Inputs	V_{in}	$V_{DD} + 0.5$ to $V_{SS} - 0.5$	Vdc
DC Current Drain per Pin	I	10	mAdc
Operating Temperature Range	T_A	-40 to +85	$^{\circ}C$
Storage Temperature Range	T_{stg}	-65 to +150	$^{\circ}C$

ELECTRICAL CHARACTERISTICS

Characteristic	Symbol	V_{DD} Vdc	-40 $^{\circ}C$		25 $^{\circ}C$			+85 $^{\circ}C$		Unit
			Min	Max	Min	Typ	Max	Min	Max	
Supply Voltage Operating Range	V_{DD}	—	3.0	6.0	3.0	5.0	6.0	3.0	6.0	Vdc
Output Voltage "0" Level "1" Level	V_{out}	5.0	—	0.01	—	0	0.01	—	0.05	Vdc
		5.0	4.99	—	4.99	5.0	—	4.95	—	Vdc
Noise Immunity ($\Delta V_{out} \leq 0.8$ Vdc)	V_{NL}	5.0	1.5	—	1.5	2.25	—	1.4	—	Vdc
	V_{NH}	5.0	1.4	—	1.5	2.25	—	1.5	—	Vdc
Output Drive Current ($V_{OH} = 2.5$ Vdc) Source ($V_{OL} = 0.4$ Vdc) Sink	I_{OH}	5.0	-0.23	—	-0.20	-1.7	—	-0.16	—	mAdc
	I_{OL}	5.0	0.23	—	0.20	0.78	—	0.16	—	mAdc
Input Leakage Current ($V_{in} = V_{DD}$)	I_{IH}	5.0	—	—	—	10	—	—	—	pAdc
Pullup Resistor Source Current (Row and Column Inputs) ($V_{in} = V_{SS}$)	I_{IL}	5.0	265	460	190	250	330	125	215	μ Adc
Input Capacitance ($V_{in} = V_{SS}$)	C_{in}	—	—	—	—	5.0	—	—	—	pF
Standby Supply Current ($f_{clock} = 16$ kHz, No Keys Depressed)	I_{DDs}	3.0	—	3.0	—	1.0	3.0	—	6.0	μ Adc
		5.0	—	15	—	5.0	15	—	30	
		6.0	—	60	—	20	60	—	120	
Standby Supply Current as a Function of Clock Frequency* (No Keys Depressed)	I_{DDs}	5.0	$I_{DDs} = 0.09 \mu A/kHz + 3.0 \mu A$							μ Adc

*The formula given is for the typical characteristics only.

SWITCHING CHARACTERISTICS ($C_L = 50$ pF, $T_A = 25^{\circ}C$)

Characteristic	Symbol	V_{DD}	Min	Typ	Max	Unit
Output Rise and Fall Times, D1 thru D4 (Figure 1)	t_r, t_f	5.0	—	300	—	ns
Propagation Delay Time, Row or Column Input to Data Output (Figure 1)	$t_{PLH},$ t_{PHL}	5.0	—	1000	—	ns
Clock Pulse Frequency Range	PRF	3.0 to 6.0	4.0	16	80	kHz

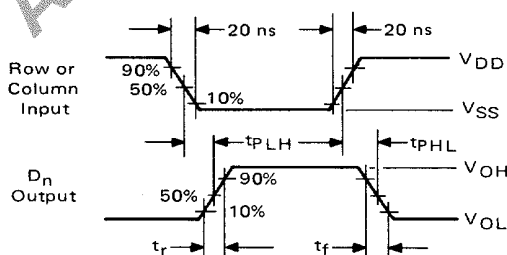
FIGURE 1 – SWITCHING TIME WAVEFORMS**FIGURE 2 – TYPICAL STROBE PULSE DELAY TIMES**

PRF Clock Frequency kHz	t_{ST}^* Strobe Pulse Delay Time ms
4.0	20
8.0	10
16	5.0
32	2.5
80	1.0

* $t_{ST} = (1/PRF) \bullet 80$, with PRF in kHz, t_{ST} in ms.

FIGURE 3 – STROBE GENERATOR TIMING DIAGRAM

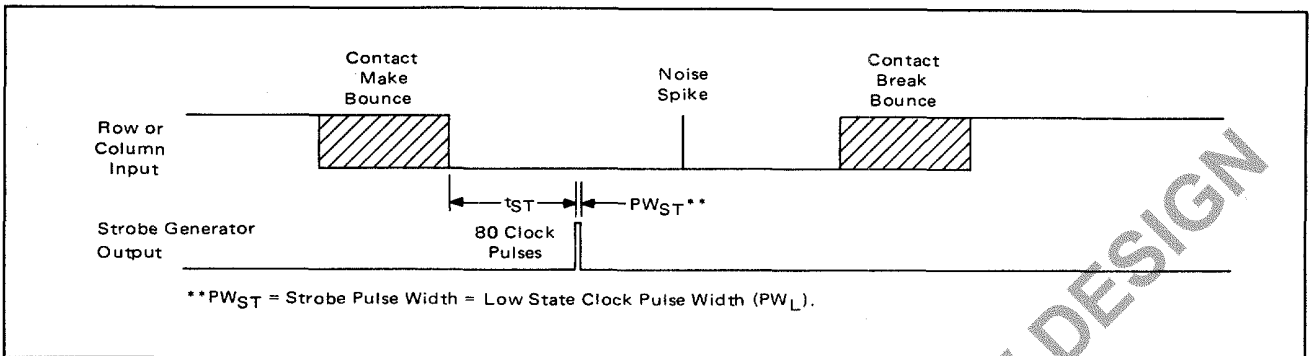

TRUTH TABLE

Key**	Inputs								Outputs				
	Row				Column				D4	D3	D2	D1	Strobe
	R4	R3	R2	R1	C4	C3	C2	C1					
1	1	1	1	0	1	1	1	0	0	0	0	1	
2	1	1	1	0	1	1	0	1	0	0	1	0	
3	1	1	1	0	1	0	1	1	0	0	1	1	
A	1	1	1	0	0	1	1	1	1	1	0	0	0
4	1	1	0	1	1	1	1	0	0	1	0	0	
5	1	1	0	1	1	1	0	1	0	1	0	1	
6	1	1	0	1	1	0	1	1	0	1	1	0	
B	1	1	0	1	0	1	1	1	1	1	0	1	0
7	1	0	1	1	1	1	1	0	0	1	1	1	
8	1	0	1	1	1	1	0	1	1	0	0	0	
9	1	0	1	1	1	0	1	1	1	0	0	1	
C	1	0	1	1	0	1	1	1	1	1	1	0	0
*	0	1	1	1	1	1	1	0	1	0	1	0	0
0	0	1	1	1	1	1	0	1	0	0	0	0	0
#	0	1	1	1	1	0	1	1	1	0	1	1	0
D	0	1	1	1	0	1	1	1	1	1	1	1	0
	All Other Combinations								0	0	0	0	0

**See Figure 4 for keypad designation.

PACKAGE DIMENSIONS

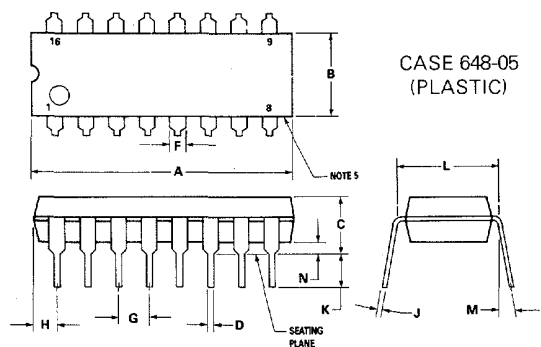
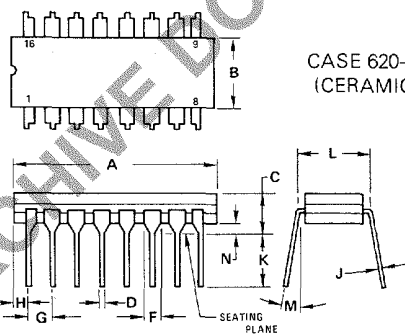

DIM	MILLIMETERS		INCHES	
	MIN	MAX	MIN	MAX
A	19.05	19.94	0.750	0.785
B	6.10	7.49	0.240	0.295
C	-	5.08	-	0.200
D	0.38	0.53	0.015	0.021
F	1.40	1.78	0.055	0.070
G	2.54 BSC		0.100 BSC	
H	0.51	1.14	0.020	0.045
J	0.20	0.30	0.008	0.012
K	3.18	4.32	0.125	0.170
L	7.62 BSC		0.300 BSC	
M	-	15°	-	15°
N	0.51	1.02	0.020	0.040

- LEADS WITHIN 0.13 mm (0.005) RADIUS OF TRUE POSITION AT SEATING PLANE AT MAXIMUM MATERIAL CONDITION.
- PACKAGE INDEX: NOTCH IN LEAD NOTCH IN CERAMIC OR INK DOT.
- DIM "L" TO CENTER OF LEADS WHEN FORMED PARALLEL.
- DIM "A" AND "B" DO NOT INCLUDE GLASS RUN-OUT.
- DIM "F" MAY NARROW TO 0.76 mm (0.030) WHERE THE LEAD ENTERS THE CERAMIC BODY.

DIM	MILLIMETERS		INCHES	
	MIN	MAX	MIN	MAX
A	18.80	21.34	0.740	0.840
B	6.10	6.60	0.240	0.260
C	4.06	5.08	0.160	0.200
D	0.38	0.53	0.015	0.021
F	1.02	1.78	0.040	0.070
G	2.54 BSC		0.100 BSC	
H	0.38	2.41	0.015	0.095
J	0.20	0.38	0.008	0.015
K	2.92	3.43	0.115	0.135
L	7.62 BSC		0.300 BSC	
M	0°	10°	0°	10°
N	0.51	1.02	0.020	0.040

- LEADS WITHIN 0.13 mm (0.005) RADIUS OF TRUE POSITION AT SEATING PLANE AT MAXIMUM MATERIAL CONDITION.
- DIMENSION "L" TO CENTER OF LEADS WHEN FORMED PARALLEL.
- DIMENSION "B" DOES NOT INCLUDE MOLD FLASH.
- "F" DIMENSION IS FOR FULL LEADS: "HALF" LEADS ARE OPTIONAL AT LEAD POSITIONS 1, 8, 9, AND 16.
- ROUNDED CORNERS OPTIONAL.



FIGURE 4 – TYPICAL KEYPAD INTERFACE APPLICATION

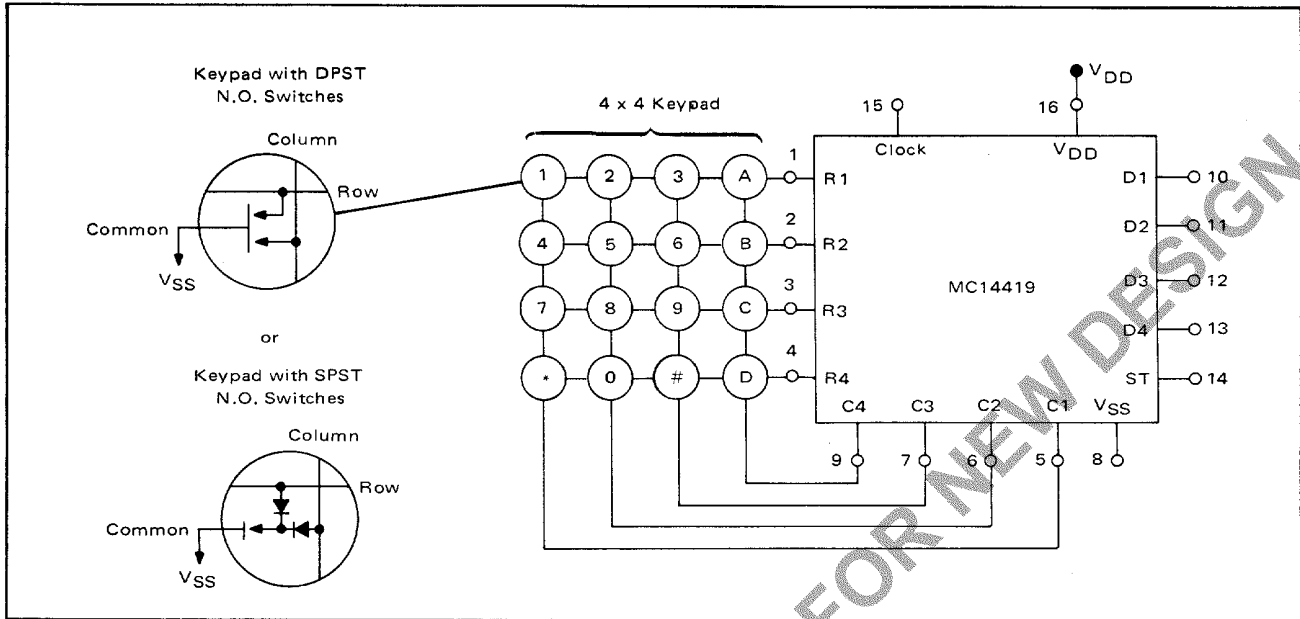
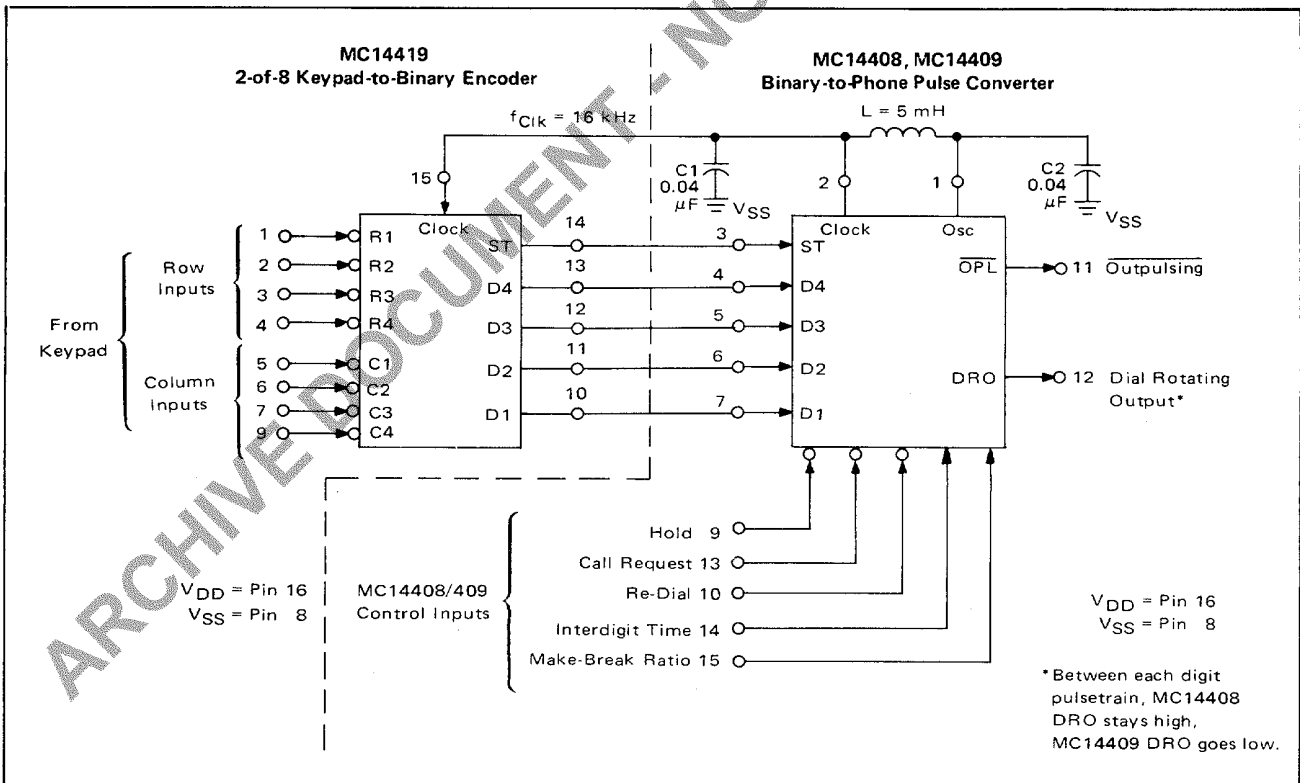

FIGURE 5 – PHONE DIALER SYSTEM



Motorola reserves the right to make changes without further notice to any products herein to improve reliability, function or design. Motorola does not assume any liability arising out of the application or use of any product or circuit described herein; neither does it convey any license under its patent rights nor the rights of others. Motorola and are registered trademarks of Motorola, Inc. Motorola, Inc. is an Equal Employment Opportunity/Affirmative Action Employer.



MOTOROLA Semiconductor Products Inc.

3501 ED BLUESTEIN BLVD., AUSTIN, TEXAS 78721 • A SUBSIDIARY OF MOTOROLA INC.