



MOTOROLA

SEMICONDUCTORS

P.O. BOX 20912 • PHOENIX, ARIZONA 85036

Product Preview

FM RECEIVER FRONT END

The MC13062 is an FM tuner device specifically designed for electronically tuned auto radios, but with frequency capability which extends its possible applications to 300 MHz.

- Large Signal Input Capability
- AGC Controls RF Stage and External PIN Diode
- Stable Oscillator is Balanced for Low Radiation
- Oscillator Buffer Output for Synthesizer
- Well Regulated Supply
- Good Temperature Stability Over Automotive Range
- Very Low Cost
- Manufactured in Motorola MOSAIC Process
- Ideal for Varactor Tuned Systems
- Drop-In Replacement for TDA1062S (NO DATA)

002404
MC13062

002404

FM RECEIVER FRONT END

MONOLITHIC SILICON INTEGRATED CIRCUIT

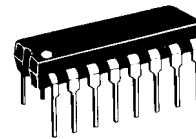

P SUFFIX
PLASTIC PACKAGE
CASE 648-06

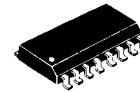

D SUFFIX
PLASTIC PACKAGE
CASE 751B-02
(SO-16)

FIGURE 1 — FUNCTIONAL BLOCK DIAGRAM

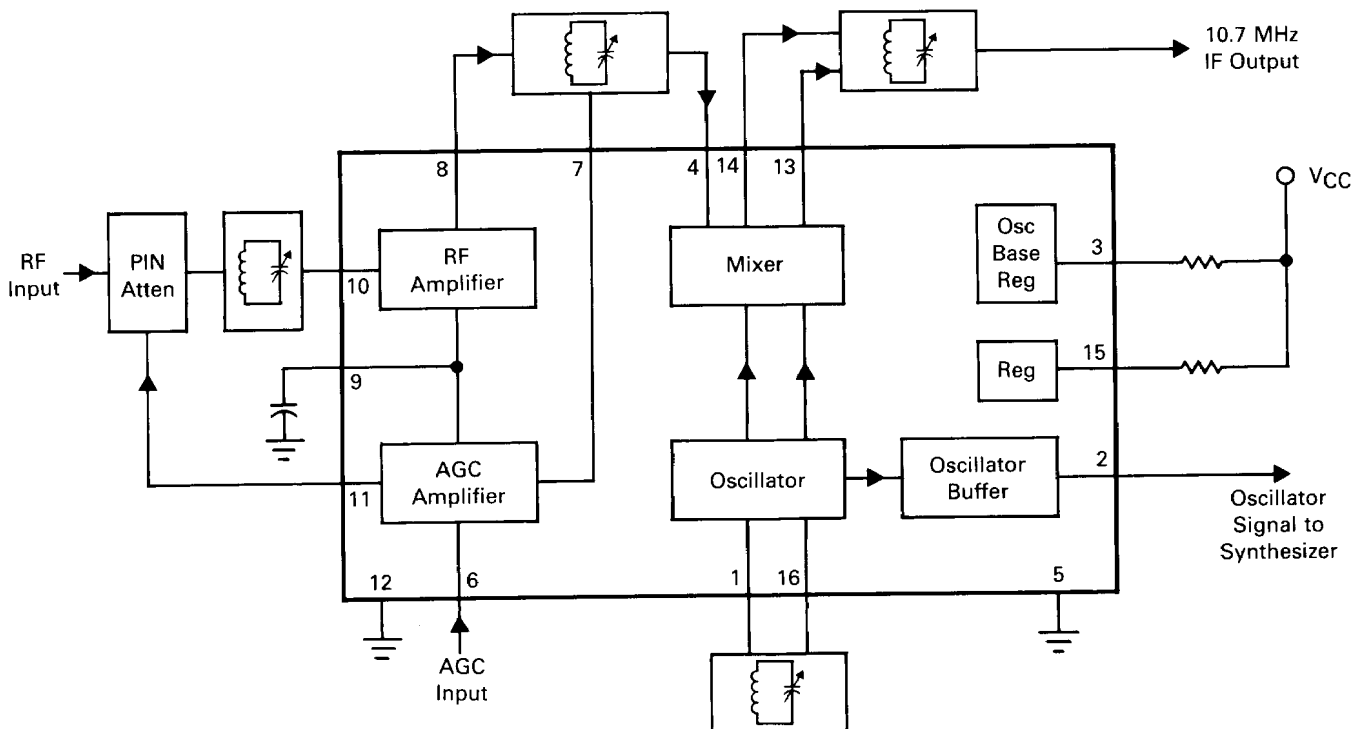

Motorola reserves the right to make changes without further notice to any products herein to improve reliability, function or design. Motorola does not assume any liability arising out of the application or use of any product or circuit described herein, neither does it convey any license under its patent rights nor the rights of others. Motorola and are registered trademarks of Motorola, Inc. Motorola, Inc. is an Equal Employment Opportunity/Affirmative Action Employer.

MAXIMUM RATINGS

Rating	Symbol	Value	Unit
Power Supply Voltage	V _{CC}	16	Vdc
Operating Supply Voltage Range	V _{CC}	8-16	Vdc
Power Dissipation @ 25°C	P _D	1.25	W
Junction Temperature	T _{J(max)}	150	°C
Operating Temperature Range	T _A	-30 to +85	°C

ELECTRICAL CHARACTERISTICS (Typical Conditions V_{CC} = 13.8 Vdc, RF Frequency 100 MHz)

Characteristic	Min	Typ	Max	Unit
Total Supply Current	—	27	—	mAdc
Mixer Input Bias Regulator	—	3.9	—	Vdc
Signal to Noise Ratio (1.0 mV, Δf = ±75 kHz)	—	60	—	dB
Detuning as Input rises from 500 μV to 1.0 V	—	±30	±120	kHz
Oscillator Drift (V _{CC} 12.75 - 9.5 Vdc)	—	±40	±120	kHz
Oscillator Drift (V _{CC} 12.75 - 16 Vdc)	—	±20	±120	kHz
Oscillator Drift versus Temperature (-30 to +25°C)	—	0.3	—	MHz
Oscillator Drift versus Temperature (-30 to +85°C)	—	0.6	—	MHz

FIGURE 2 — INTERNAL SCHEMATIC

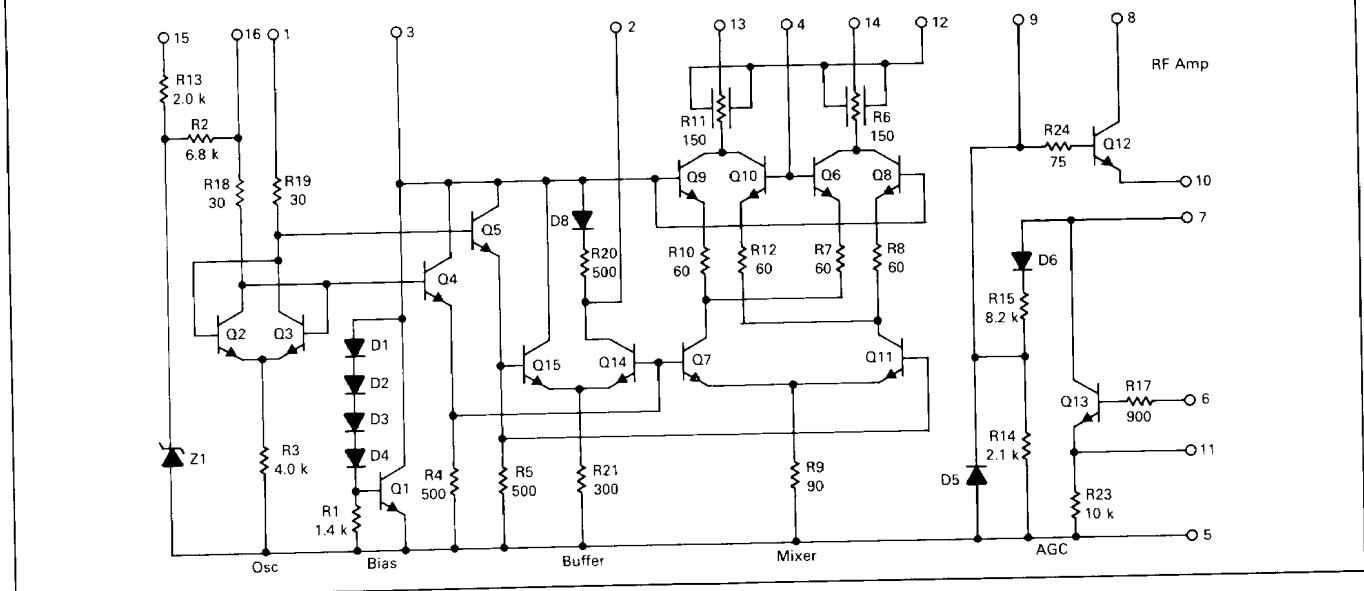

OUTLINE DIMENSIONS

CASE 648-06
PLASTIC PACKAGE
 $R_{\theta JA} = 100^{\circ}\text{C/W}$ (Typ)

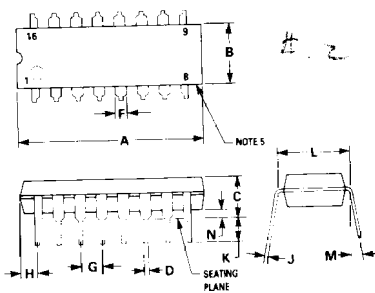

- NOTES:
- LEADS WITHIN 0.13 mm (0.005) RADIUS OF TRUE POSITION AT SEATING PLANE AT MAXIMUM MATERIAL CONDITION.
 - DIMENSION "L" TO CENTER OF LEADS WHEN FORMED PARALLEL.
 - DIMENSION "B" DOES NOT INCLUDE MOLD FLASH.
 - "F" DIMENSION IS FOR FULL LEADS.
 - ROUNDED CORNERS OPTIONAL.

DIM	MILLIMETERS		INCHES	
	MIN	MAX	MIN	MAX
A	18.80	21.34	0.740	0.840
B	6.10	6.60	0.240	0.260
C	3.69	4.69	0.145	0.185
D	0.38	0.53	0.015	0.021
F	1.02	1.78	0.040	0.070
G	2.54 BSC		0.100 BSC	
H	0.38	2.41	0.015	0.095
J	0.20	0.38	0.008	0.015
K	2.92	3.43	0.115	0.135
L	7.62 BSC		0.300 BSC	
M	0°	10°	0°	10°
N	0.39	1.01	0.015	0.040

CASE 751B-02
SO-16
PLASTIC PACKAGE
 $R_{\theta JA} = 135^{\circ}\text{C/W}$

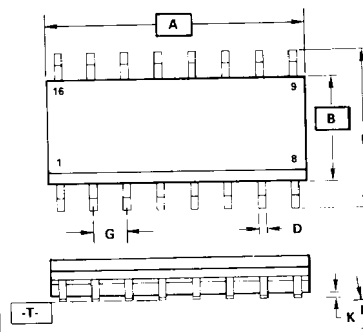

- NOTES:
- DIMENSIONS A AND B ARE DATUMS AND T IS A DATUM SURFACE.
 - POSITIONAL TOLERANCE FOR TERMINALS D DIMENSION, 16 PLACES.
 ± 0.25 (0.010) (M) (T) (A) (B) (S)
 - POSITIONAL TOLERANCE FOR P DIMENSIONING, 8 PLACES.
 ± 0.25 (0.010) (M) (T) (A) (B) (S)
 - DIMENSIONING AND TOLERANCING PER Y14.5M, 1982
 - CONTROLLING DIMENSION: INCH

DIM	MILLIMETERS		INCHES	
	MIN	MAX	MIN	MAX
A	10.16	10.43	0.400	0.411
B	7.38	7.59	0.291	0.299
C	2.36	2.64	0.093	0.104
D	0.36	0.48	0.014	0.019
F	0.51	0.88	0.020	0.035
G	1.27 BSC		0.050 BSC	
J	0.20	0.30	0.010	0.012
K	0.10	0.25	0.004	0.010
M	0°	7°	0°	7°
P	10.08	10.54	0.397	0.415



MOTOROLA Semiconductor Products Inc.

BOX 20912 • PHOENIX, ARIZONA 85036 • A SUBSIDIARY OF MOTOROLA INC.