

*Product Preview***MCU with LCD driver**

The MC68HC05L6 HCMOS microcomputer unit is a member of the MC68HC05 family of low-cost single-chip microcomputers. This 8-bit microcomputer contains an on-chip oscillator, CPU, RAM, ROM, I/O, Serial Peripheral Interface, timer, liquid crystal display driver circuitry and a tone generator.

The following are some of the hardware and software highlights of the MC68HC05L6 microcomputer.

Hardware features:

- HCMOS technology
- 8-bit architecture
- Power saving Stop and Wait modes
- RAM and CPU register contents valid at $V_{CC} = 2.0$ Volts (CPU halted)
- Independent power supplies (CPU – LCD) 8 to 6 Volt operation
- 178 bytes of on-Chip RAM
- 6208 bytes of on-Chip ROM
- 24 bidirectional I/O Lines
- 4.0 MHz internal operating frequency at 5 Volts
- Internal 16-bit timer similar to MC6801 timer
- Serial Peripheral Interface system
- Self-check mode
- External, Timer, and Serial Peripheral Interface interrupts
- Master Reset and Power-On Reset
- On-chip oscillator with RC or Crystal/Ceramic Resonator mask options
- LCD 2/3, 1/3 VL Divider Circuitry included
- Tone generator
- 68-pin Quad Package

Software features:

- Similar to MC6800
- 8 x 8 unsigned Multiply Instruction
- Efficient Use of Program Space
- Versatile Interrupt Handling
- True Bit Manipulation
- Indexed Addressing for Tables
- Efficient Instruction Set
- Memory Mapped I/O
- Programmable LCD Driver Circuitry
 - 96 Pixels in x 4 Mode
 - 72 Pixels in x 3 Mode
- Low Cost Development Support with Evaluation Module.

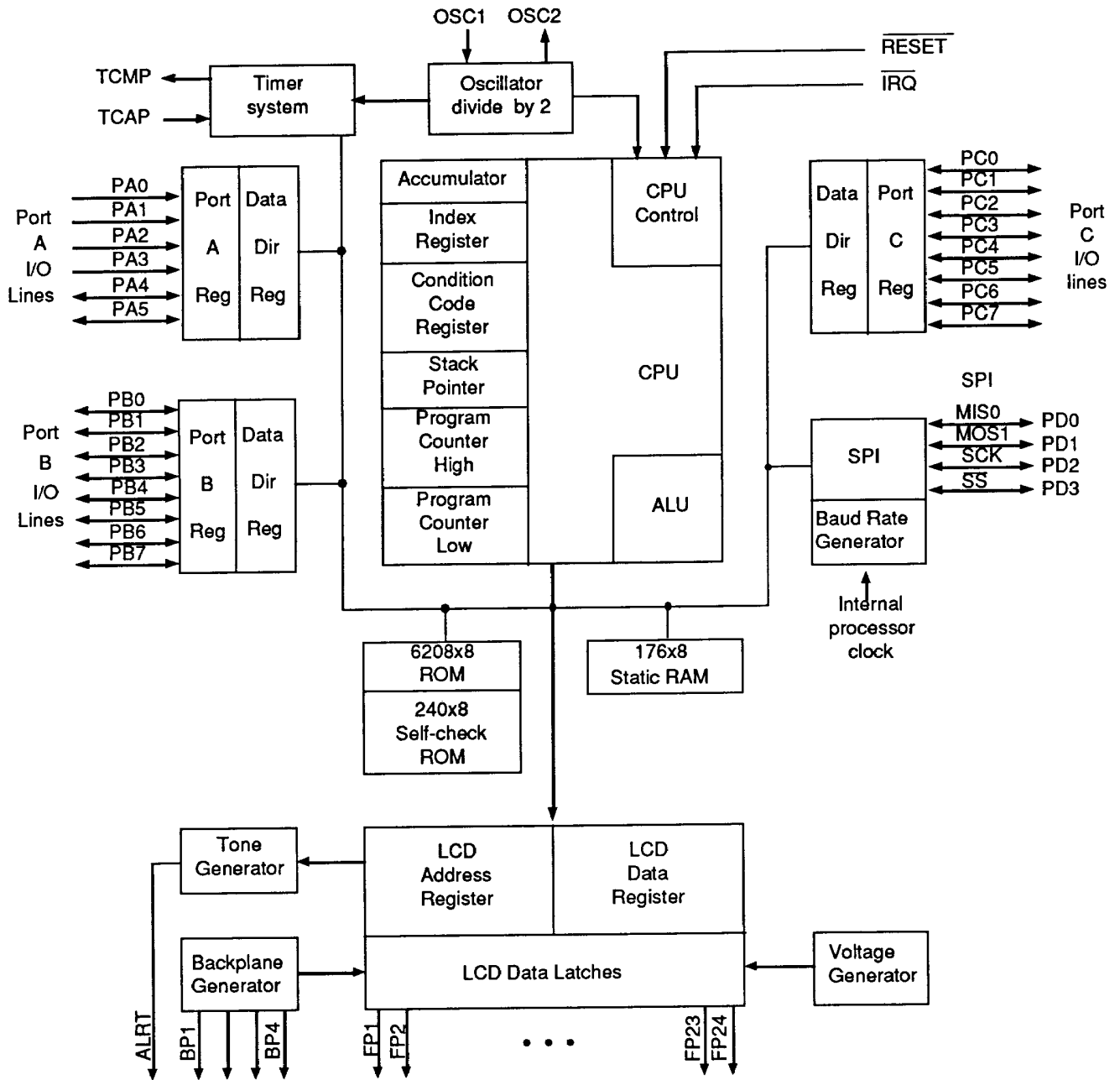

MC68HC05L6 Microcomputer Block Diagram

Introduction

This brochure is a summary of Motorola's range of devices designed for use in the Telecommunications industry. This wide range of devices has many applications, including:

- ISDN Terminals and Digital Telephones
- ISDN Central Office
- Digital PABX and key systems
- Digital mobile and cordless telephones
- Modems and transmissions
- Analog Telephones
- Analog Central Office
- Analog PABX and key systems
- Analog mobile and cordless telephones
- Voice storage.

Those applications are covered in Sections 1–8 of this brochure, as shown below.

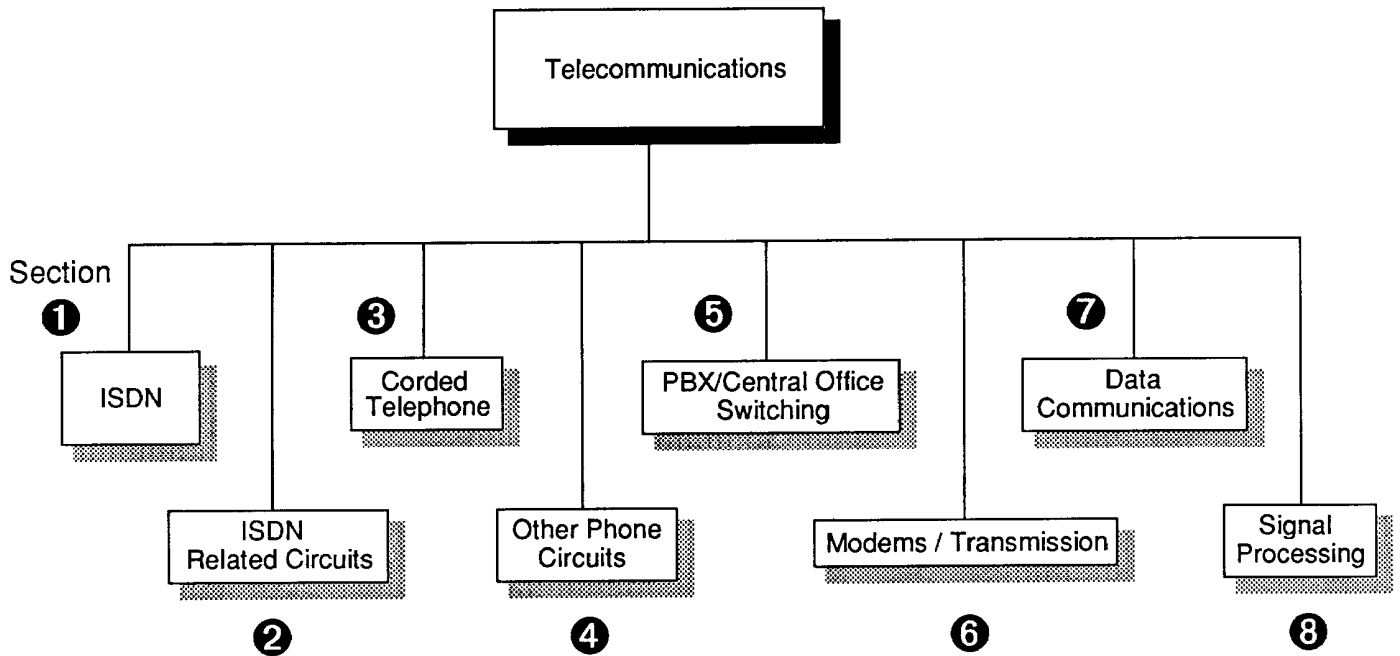

Please note that Radio Communication applications are covered in other Guides. The range is continually increasing and more devices are being introduced all the time.

For more information on any of these devices, please contact your local Motorola sales office or distributor.