

## Encoder and Decoder Pairs CMOS

These devices are designed to be used as encoder/decoder pairs in remote control applications.

The MC145026 encodes nine lines of information and serially sends this information upon receipt of a transmit enable (TE) signal. The nine lines may be encoded with trinary data (low, high, or open) or binary data (low or high). The words are transmitted twice per encoding sequence to increase security.

The MC145027 decoder receives the serial stream and interprets five of the trinary digits as an address code. Thus, 243 addresses are possible. If binary data is used at the encoder, 32 addresses are possible. The remaining serial information is interpreted as four bits of binary data. The valid transmission output (VT) goes high on the MC145027 when two conditions are met. First, two addresses must be consecutively received (in one encoding sequence) which both match the local address. Second, the 4-bits of data must match the last valid data received. The active VT indicates that the information at the data output pins has been updated.

The MC145028 decoder treats all nine trinary digits as an address which allows 19,683 codes. If binary data is encoded, 512 codes are possible. The valid transmission output (VT) goes high on the MC145028 when two addresses are consecutively received (in one encoding sequence) which both match the local address.

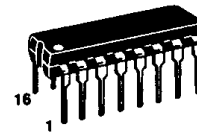
- Operating Temperature Range: -40° to 85°C
- Very-Low Standby Current for the Encoder: 300 nA Maximum @ 25°C
- Interfaces with RF, Ultrasonic, or Infrared Modulators and Demodulators
- RC Oscillator, No Crystal Required
- High External Component Tolerance; Can Use ±5% Components
- Internal Power-On Reset Forces All Decoder Outputs Low
- For Infrared Applications, See Applications Note AN1016
- Operating Voltage Range: 4.5 to 18 V
- Low-Voltage Versions Available —

SC41342: 2.5 to 18 V Version of the MC145026

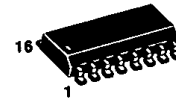
SC41343: 2.8 to 10 V Version of the MC145027

SC41344: 2.8 to 10 V Version of the MC145028

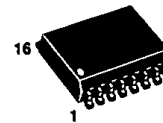
**MC145026**  
**MC145027**  
**MC145028**  
**SC41342**  
**SC41343**  
**SC41344**



**P SUFFIX**  
**PLASTIC DIP**  
**CASE 648**



**D SUFFIX**  
**SOG**  
**CASE 751B**

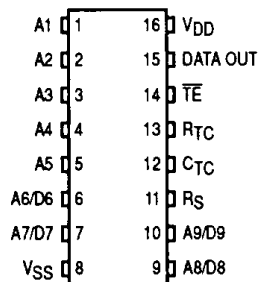


**DW SUFFIX**  
**SOG**  
**CASE 751G**

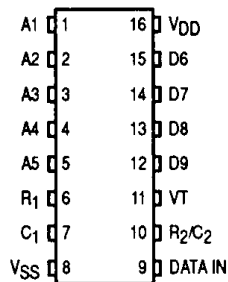
### ORDERING INFORMATION

MC145026P, SC41342P	Plastic DIP
MC145026D, SC41342D	SOG Package
MC145027P, SC41343P	Plastic DIP
MC145027DW, SC41343DW	SOG Package
MC145028P, SC41344P	Plastic DIP
MC145028DW, SC41344DW	SOG Package

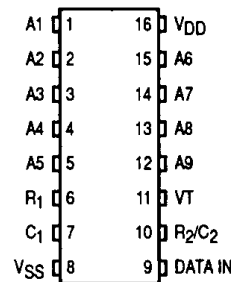
### PIN ASSIGNMENTS



MC145026  
 SC41342  
 ENCODERS



MC145027  
 SC41343  
 DECODERS



MC145028  
 SC41344  
 DECODERS

MC145026•MC145027•MC145028•  
SC41342•SC41343•SC41344

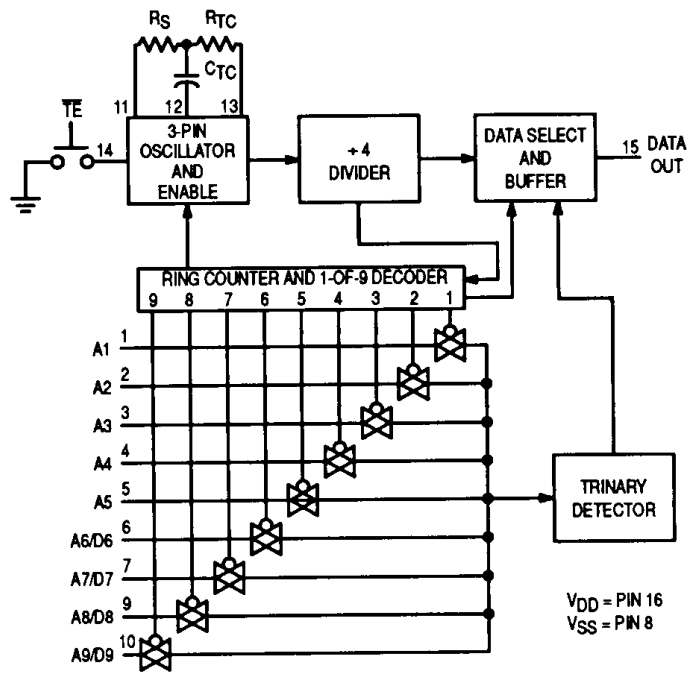


Figure 1. MC145026 Encoder Block Diagram

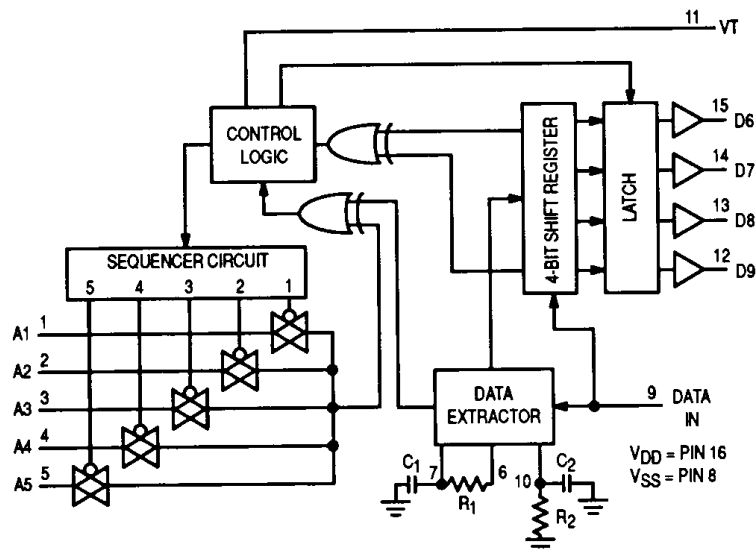


Figure 2. MC145027 Decoder Block Diagram



**MC145026•MC145027•MC145028•  
SC41342•SC41343•SC41344**

**ELECTRICAL CHARACTERISTICS — MC145026, MC145027, MC145028, and SC41342\* (Voltage Referenced to V<sub>SS</sub>)**

Symbol	Characteristic	V <sub>DD</sub> V	Guaranteed Limit						Unit
			-40°C		25°C		+85°C		
			Min	Max	Min	Max	Min	Max	
V <sub>OL</sub>	Low-Level Output Voltage (V <sub>in</sub> = V <sub>DD</sub> or 0)	5.0	—	0.05	—	0.05	—	0.05	V
		10	—	0.05	—	0.05	—	0.05	
		15	—	0.05	—	0.05	—	0.05	
V <sub>OH</sub>	High-Level Output Voltage (V <sub>in</sub> = 0 or V <sub>DD</sub> )	5.0	4.95	—	4.95	—	4.95	—	V
		10	9.95	—	9.95	—	9.95	—	
		15	14.95	—	14.95	—	14.95	—	
V <sub>IL</sub>	Low-Level Input Voltage (V <sub>out</sub> = 4.5 or 0.5 V) (V <sub>out</sub> = 9.0 or 1.0 V) (V <sub>out</sub> = 13.5 or 1.5 V)	5.0	—	1.5	—	1.5	—	1.5	V
		10	—	3.0	—	3.0	—	3.0	
		15	—	4.0	—	4.0	—	4.0	
V <sub>IH</sub>	High-Level Input Voltage (V <sub>out</sub> = 0.5 or 4.5 V) (V <sub>out</sub> = 1.0 or 9.0 V) (V <sub>out</sub> = 1.5 or 13.5 V)	5.0	3.5	—	3.5	—	3.5	—	V
		10	7.0	—	7.0	—	7.0	—	
		15	11	—	11	—	11	—	
I <sub>OH</sub>	High-Level Output Current (V <sub>out</sub> = 2.5 V) (V <sub>out</sub> = 4.6 V) (V <sub>out</sub> = 9.5 V) (V <sub>out</sub> = 13.5 V)	5.0	-2.5	—	-2.1	—	-1.7	—	mA
		5.0	-0.52	—	-0.44	—	-0.36	—	
		10	-1.3	—	-1.1	—	-0.9	—	
		15	-3.6	—	-3.0	—	-2.4	—	
I <sub>OL</sub>	Low-Level Output Current (V <sub>out</sub> = 0.4 V) (V <sub>out</sub> = 0.5 V) (V <sub>out</sub> = 1.5 V)	5.0	0.52	—	0.44	—	0.36	—	mA
		10	1.3	—	1.1	—	0.9	—	
		15	3.6	—	3.0	—	2.4	—	
I <sub>in</sub>	Input Current — $\overline{TE}$ (MC145026 and SC41342, Pullup Device)	5.0	—	—	3.0	11	—	—	μA
		10	—	—	16	60	—	—	
		15	—	—	35	120	—	—	
I <sub>in</sub>	Input Current R <sub>S</sub> (MC145026 and SC41342), Data In (MC145027, MC145028)	15	—	±0.3	—	±0.3	—	±1.0	μA
I <sub>in</sub>	Input Current A1-A5, A6/D6-A9/D9 (MC145026 and SC41342), A1-A5 (MC145027), A1-A9 (MC145028)	5.0	—	—	—	±110	—	—	μA
		10	—	—	—	±500	—	—	
		15	—	—	—	±1000	—	—	
C <sub>in</sub>	Input Capacitance (V <sub>in</sub> = 0)	—	—	—	—	7.5	—	—	pF
I <sub>DD</sub>	Quiescent Current — MC145026 and SC41342	5.0	—	—	—	0.1	—	—	μA
		10	—	—	—	0.2	—	—	
		15	—	—	—	0.3	—	—	
I <sub>DD</sub>	Quiescent Current — MC145027, MC145028	5.0	—	—	—	50	—	—	μA
		10	—	—	—	100	—	—	
		15	—	—	—	150	—	—	
I <sub>dd</sub>	Dynamic Supply Current — MC145026 and SC41342 (f <sub>c</sub> = 20 kHz)	5.0	—	—	—	200	—	—	μA
		10	—	—	—	400	—	—	
		15	—	—	—	600	—	—	
I <sub>dd</sub>	Dynamic Supply Current — MC145027, MC145028 (f <sub>c</sub> = 20 kHz)	5.0	—	—	—	400	—	—	μA
		10	—	—	—	800	—	—	
		15	—	—	—	1200	—	—	

\*Also see next Electrical Characteristics table for 2.5 V specifications.

**MC145026•MC145027•MC145028•  
SC41342•SC41343•SC41344**

**ELECTRICAL CHARACTERISTICS — SC41342 (Voltage Referenced to V<sub>SS</sub>)**

Symbol	Characteristic	V <sub>DD</sub> V	Guaranteed Limit						Unit
			-40°C		25°C		+85°C		
			Min	Max	Min	Max	Min	Max	
V <sub>OL</sub>	Low-Level Output Voltage (V <sub>in</sub> = 0 V or V <sub>DD</sub> )	2.5	—	0.05	—	0.05	—	0.05	V
V <sub>OH</sub>	High-Level Output Voltage (V <sub>in</sub> = 0 V or V <sub>DD</sub> )	2.5	2.45	—	2.45	—	2.45	—	V
V <sub>IL</sub>	Low-Level Input Voltage (V <sub>out</sub> = 0.5 V or 2.0 V)	2.5	—	0.3	—	0.3	—	0.3	V
V <sub>IH</sub>	High-Level Input Voltage (V <sub>out</sub> = 0.5 V or 2.0 V)	2.5	2.2	—	2.2	—	2.2	—	V
I <sub>OH</sub>	High-Level Output Current (V <sub>out</sub> = 1.25 V)	2.5	0.28	—	0.25	—	0.2	—	mA
I <sub>OL</sub>	Low-Level Output Current (V <sub>out</sub> = 0.4 V)	2.5	0.22	—	0.2	—	0.16	—	mA
I <sub>in</sub>	Input Current (TE — Pullup Device)	2.5	—	—	0.09	1.8	—	—	μA
I <sub>in</sub>	Input Current (A1-A5, A6/D6-A9/D9)	2.5	—	—	—	±25	—	—	μA
I <sub>DD</sub>	Quiescent Current	2.5	—	—	—	0.05	—	—	μA
I <sub>dd</sub>	Dynamic Supply Current (f <sub>c</sub> = 20 kHz)	2.5	—	—	—	40	—	—	μA

**MC145026•MC145027•MC145028•  
SC41342•SC41343•SC41344**

**ELECTRICAL CHARACTERISTICS — SC41343 and SC41344 (Voltage Referenced to V<sub>SS</sub>)**

Symbol	Characteristic	V <sub>DD</sub> V	Guaranteed Limit						Unit
			-40°C		25°C		+85°C		
			Min	Max	Min	Max	Min	Max	
V <sub>OL</sub>	Low-Level Output Voltage (V <sub>in</sub> = 0 V or V <sub>DD</sub> )	2.8	—	0.05	—	0.05	—	0.05	V
		5.0	—	0.05	—	0.05	—	0.05	
		10	—	0.05	—	0.05	—	0.05	
V <sub>OH</sub>	High-Level Output Voltage (V <sub>in</sub> = 0 V or V <sub>DD</sub> )	2.8	2.75	—	2.75	—	2.75	—	V
		5.0	4.95	—	4.95	—	4.95	—	
		10	9.95	—	9.95	—	9.95	—	
V <sub>IL</sub>	Low-Level Input Voltage (V <sub>out</sub> = 2.3 V or 0.5 V) (V <sub>out</sub> = 4.5 V or 0.5 V) (V <sub>out</sub> = 9.0 V or 1.0 V)	2.8	—	0.84	—	0.84	—	0.84	V
		5.0	—	1.5	—	1.5	—	1.5	
		10	—	3.0	—	3.0	—	3.0	
V <sub>IH</sub>	High-Level Input Voltage (V <sub>out</sub> = 0.5 V or 2.3 V) (V <sub>out</sub> = 0.5 V or 4.5 V) (V <sub>out</sub> = 1.0 V or 9.0 V)	2.8	1.96	—	1.96	—	1.96	—	V
		5.0	3.5	—	3.5	—	3.5	—	
		10	7.0	—	7.0	—	7.0	—	
I <sub>OH</sub>	High-Level Output Current (V <sub>out</sub> = 1.4 V) (V <sub>out</sub> = 4.5 V) (V <sub>out</sub> = 9.0 V)	2.8	-0.73	—	-0.7	—	-0.55	—	mA
		5.0	-0.59	—	-0.5	—	-0.41	—	
		10	-1.3	—	-1.1	—	-0.9	—	
I <sub>OL</sub>	Low-Level Output Current (V <sub>out</sub> = 0.4 V) (V <sub>out</sub> = 0.5 V) (V <sub>out</sub> = 1.0 V)	2.8	0.35	—	0.3	—	0.24	—	mA
		5.0	0.8	—	0.6	—	0.4	—	
		10	3.5	—	2.9	—	2.3	—	
I <sub>in</sub>	Input Current — Data In	10	—	±0.3	—	±0.3	—	±1.0	μA
I <sub>in</sub>	Input Current A1-A5 (SC41343), A1-A9 (SC41344)	2.8	—	—	—	±30	—	—	μA
		5.0	—	—	—	±140	—	—	
		10	—	—	—	±600	—	—	
C <sub>in</sub>	Input Capacitance (V <sub>in</sub> = 0)	—	—	—	—	7.5	—	—	pF
I <sub>DD</sub>	Quiescent Current	2.8	—	—	—	60	—	—	μA
		5.0	—	—	—	75	—	—	
		10	—	—	—	150	—	—	
I <sub>DD</sub>	Dynamic Supply Current (f <sub>c</sub> = 20 kHz)	2.8	—	—	—	300	—	—	μA
		5.0	—	—	—	500	—	—	
		10	—	—	—	1000	—	—	

**6**

**MC145026•MC145027•MC145028•  
SC41342•SC41343•SC41344**

**SWITCHING CHARACTERISTICS — MC145026, MC145027, MC145028, and SC41342\* (C<sub>L</sub> = 50 pF, T<sub>A</sub> = 25°C)**

Symbol	Characteristic	V <sub>DD</sub>	Guaranteed Limit		Unit
			Min	Max	
t <sub>TLH</sub> , t <sub>THL</sub>	Output Transition Time (Figures 4 and 8)	5.0	—	200	ns
		10	—	100	
		15	—	80	
t <sub>r</sub>	Data In Rise Time (Decoders) (Figure 5)	5.0	—	15	μs
		10	—	15	
		15	—	15	
t <sub>f</sub>	Data In Fall Time (Decoders) (Figure 5)	5.0	—	15	μs
		10	—	5.0	
		15	—	4.0	
f <sub>osc</sub>	Encoder Clock Frequency (Figure 6)	5.0	0.001	2.0	MHz
		10	0.001	5.0	
		15	0.001	10	
f	Decoder Frequency (Referenced to Encoder Clock) (Figure 14)	5.0	1.0	240	kHz
		10	1.0	410	
		15	1.0	450	
t <sub>w</sub>	TE Pulse Width (Encoders) (Figure 7)	5.0	65	—	ns
		10	30	—	
		15	20	—	

\*Also see next Switching Characteristics table for 2.5 V specifications.

**SWITCHING CHARACTERISTICS — SC41342 (C<sub>L</sub> = 50 pF, T<sub>A</sub> = 25°C)**

Symbol	Characteristic	V <sub>DD</sub>	Guaranteed Limit		Unit
			Min	Max	
t <sub>TLH</sub> , t <sub>THL</sub>	Output Transition Time (Figures 4 and 8)	2.5	—	450	ns
f <sub>osc</sub>	Encoder Clock Frequency (Figure 6)	2.5	1.0	250	kHz
t <sub>w</sub>	TE Pulse Width (Figure 7)	2.5	—	—	ns

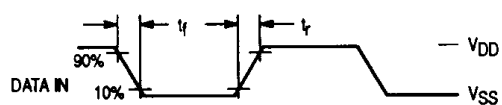
**SWITCHING CHARACTERISTICS — SC41343 and SC41344 (C<sub>L</sub> = 50 pF, T<sub>A</sub> = 25°C)**

Symbol	Characteristic	V <sub>DD</sub>	Guaranteed Limit		Unit
			Min	Max	
t <sub>TLH</sub> , t <sub>THL</sub>	Output Transition Time (Figures 4 and 8)	2.8	—	320	ns
		5.0	—	200	
		10	—	100	
t <sub>r</sub>	Data In Rise Time (Figure 5)	2.8	—	15	μs
		5.0	—	15	
		10	—	15	
t <sub>f</sub>	Data In Fall Time (Figure 5)	2.8	—	15	μs
		5.0	—	15	
		10	—	5.0	
f	Decoder Frequency (Referenced to Encoder Clock) (Figure 14)	2.8	1.0	100	kHz
		5.0	1.0	240	
		10	1.0	410	

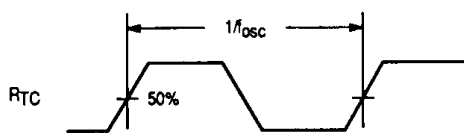
**MC145026•MC145027•MC145028•  
SC41342•SC41343•SC41344**



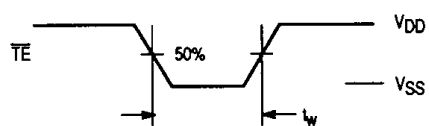
**Figure 4.**



**Figure 5.**

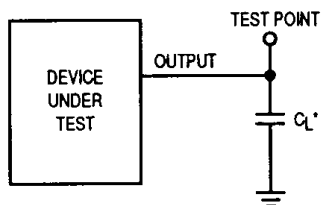


**Figure 6.**



**Figure 7.**

**6**



\*INCLUDES ALL PROBE AND JIG CAPACITANCE.

**Figure 8. Test Circuit**



## OPERATING CHARACTERISTICS

### MC145026

The encoder serially transmits trinary data as defined by the state of the A1 through A5 and A6/D6 through A9/D9 input pins. These pins may be in either of three states (low, high, or open) allowing 19,683 possible codes. The transmit sequence is initiated by a low level on the  $\overline{TE}$  input pin. Each time the  $\overline{TE}$  input is forced low, the encoder outputs two identical data words. Between the two data words, no signal is sent for three data periods. If the  $\overline{TE}$  input is kept low, the encoder continuously transmits the data word. See Figure 10.

Each transmitted trinary digit is encoded into pulses (See Figure 11). A logic zero (low) is encoded as two consecutive short pulses, a logic one (high) as two consecutive long pulses, and an open (high-impedance) as a long pulse followed by a short pulse. The input state is determined by using a weak "output" device to try to force each input first low, then high. If only a high state results from the two tests, the input is assumed to be hardwired to  $V_{DD}$ . If only a low state is obtained, the input is assumed to be hardwired to  $V_{SS}$ . If both a high and a low can be forced at an input, an open is assumed and is encoded as such. The "high" and "low" levels are 70% and 30% of the supply voltage as shown in the Electrical Characteristics Table. The weak "output" device sinks/sources up to 110  $\mu$ A at a 5 V supply level, 500  $\mu$ A at 10 V, and 1 mA at 15 V.

The  $\overline{TE}$  input has an internal pullup device so that a simple switch may be used to force the input low. While  $\overline{TE}$  is high, the encoder is completely disabled, the oscillator is inhibited, and the current drain is reduced to quiescent current. When  $\overline{TE}$  is brought low, the oscillator is started, and the transmit sequence begins. The inputs are then sequentially selected, and determinations are made as to the input logic states. This information is serially transmitted via the Data Out pin.

### MC145027

This decoder receives the serial data from the encoder and outputs the data, if it is valid. The transmitted data, consisting of two identical words, is examined bit by bit during reception. The first five trinary digits are assumed to be the address. If the received address matches the local address, next four (data) bits are internally stored, but are not transferred to the output data latch. As the second encoded word is received, the address must again match. If a match occurs, the new data bits are checked against the previously stored data bits. If the two nibbles of data (four bits each) match, the data is transferred to the output data latch by VT and remains until new data replaces it. At the same time, the VT output pin is brought high and remains high until an error is received or until no input signal is received for four data periods. See Figure 10.

Although the address information may be encoded in trinary, the data information must be either a one or a zero. A trinary (open) data line is decoded as a logic one.

### MC145028

This decoder operates in the same manner as the MC145027 except that nine address lines are used and no data output is available. The VT output is used to indicate that a valid address has been received. For transmission security, two identical transmitted words must be consecutively received before a valid transmission output (VT) signal is issued.

The MC145028 allows 19,683 addresses when trinary levels are used. 512 addresses are possible when binary levels are used.

## PIN DESCRIPTIONS

### MC145026 ENCODER

#### A1 through A5, A6/D6 through A9/D9 (Pins 1 through 7, 9, and 10)

These address/data inputs are encoded and the data is sent serially from the encoder via the data out pin.

#### $R_S$ , $C_{TC}$ , $R_{TC}$ (Pins 11, 12, and 13)

These pins are part of the oscillator section of the encoder. See Figure 9.

If an external signal source is used instead of the internal oscillator, it should be connected to the  $R_S$  input and the  $R_{TC}$  and  $C_{TC}$  pins should be left open.

#### $\overline{TE}$ (Pin 14)

This active-low transmit enable input initiates transmission when forced low. An internal pullup device keeps this input normally high. The pullup current is specified in the Electrical Characteristics table.

#### Data Out (Pin 15)

This is the output of the encoder that serially presents the encoded data word.

#### $V_{SS}$ (Pin 8)

The most-negative supply potential. This pin is usually ground.

#### $V_{DD}$ (Pin 16)

The most-positive power supply pin.

### MC145027 AND MC145028 DECODERS

#### A1 through A5 (Pins 1 through 5) — MC145027 A1 through A9 (Pins 1 through 5, 15, 14, 13, and 12) — MC145028

These are the local address inputs. The states of these pins must match the appropriate encoder inputs for the VT pin to go high. The local address may be encoded with trinary or binary data.

#### D6 through D9 (Pins 15, 14, 13, and 12) — MC145027 ONLY

These outputs present the binary information that is on encoder inputs A6/D6 through A9/D9. Only binary data is acknowledged; a trinary open at the MC145026 encoder is decoded as a high level (logic 1).

#### $R_1$ , $C_1$ (Pins 6, 7)

As shown in Figures 2 and 3, these pins accept a resistor and capacitor that are used to determine whether a narrow pulse or wide pulse has been received. The time constant  $R_1 \times C_1$  should be set to 1/72 encoder clock periods:

$$R_1 C_1 = 3.95 R_{TC} C_{TC}$$

**MC145026•MC145027•MC145028•  
SC41342•SC41343•SC41344**

**R<sub>2</sub>/C<sub>2</sub> (Pin 10)**

As shown in Figures 2 and 3, this pin accepts a resistor and capacitor that are used to detect both the end of a received word and the end of a transmission. The time constant R<sub>2</sub> x C<sub>2</sub> should be 33.5 encoder clock periods (four data periods per Figure 11): R<sub>2</sub> C<sub>2</sub> = 77 R<sub>TC</sub> C<sub>TC</sub>. This time constant is used to determine whether the data in pin has remained low for four data periods (end of transmission). A separate on-chip comparator looks at the voltage-equivalent two data periods (0.4 R<sub>2</sub> C<sub>2</sub>) to detect the dead time between received words within a transmission.

**VT (Pin 11)**

This valid transmission output goes high after the second word of an encoding sequence when the following conditions are satisfied:

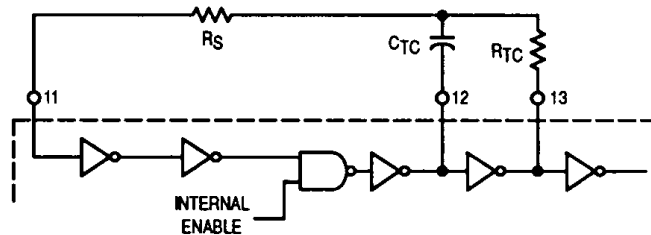
- (1) the received addresses of both words match the local decoder address, and
  - (2) the received data bits of both words match.
- VT remains high until either a mismatch is received or no input signal is received for four data periods.

**VSS (Pin 8)**

The most-negative supply potential. This pin is usually ground.

**VDD (Pin 16)**

The most-positive power supply pin.



This oscillator operates at a frequency determined by the external RC network; i.e.,

$$f \approx \frac{1}{2.3 R_{TC} C_{TC}'} \text{ (Hz)}$$

for 1 kHz ≤ f ≤ 400 kHz

where: C<sub>TC</sub>' = C<sub>TC</sub> + C<sub>layout</sub> + 12 pF

R<sub>S</sub> ≈ 2 R<sub>TC</sub>

R<sub>S</sub> ≥ 20 k

R<sub>TC</sub> ≥ 10 k

400 pF < C<sub>TC</sub> < 15 μF

The value for R<sub>S</sub> should be chosen to be ≥ 2 times R<sub>TC</sub>. This range ensures that current through R<sub>S</sub> is insignificant compared to current through R<sub>TC</sub>. The upper limit for R<sub>S</sub> must ensure that R<sub>S</sub> x 5 pF (input capacitance) is small compared to R<sub>TC</sub> x C<sub>TC</sub>.

For frequencies outside the indicated range, the formula is less accurate. The minimum recommended oscillation frequency of this circuit is 1 kHz. Susceptibility to externally induced noise signals may occur for frequencies below 1 kHz and/or when resistors utilized are greater than 1 MΩ.

**Figure 9. Encoder Oscillator Information**

**6**

**MC145026•MC145027•MC145028•  
SC41342•SC41343•SC41344**

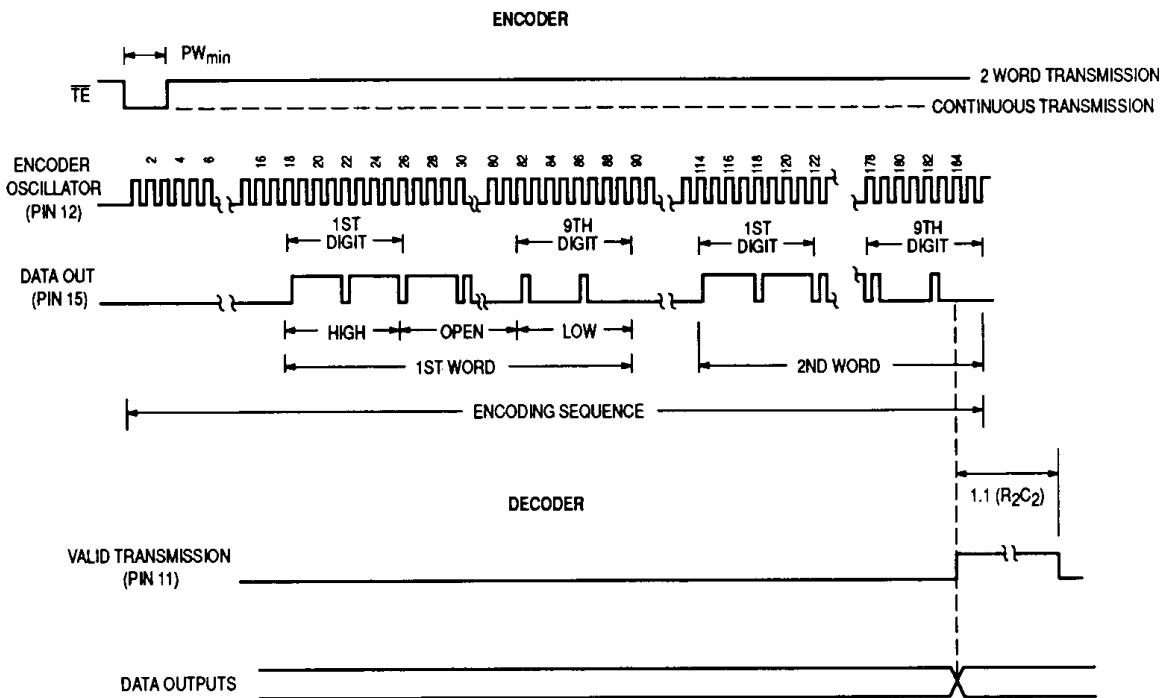


Figure 10. Timing Diagram

**6**

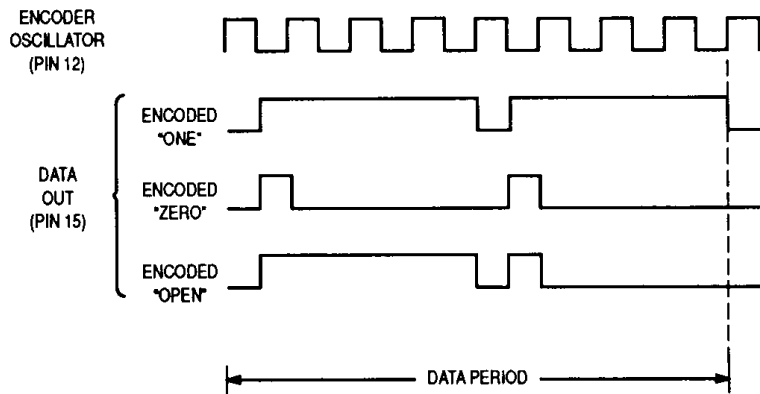


Figure 11. Encoder Data Waveforms

6

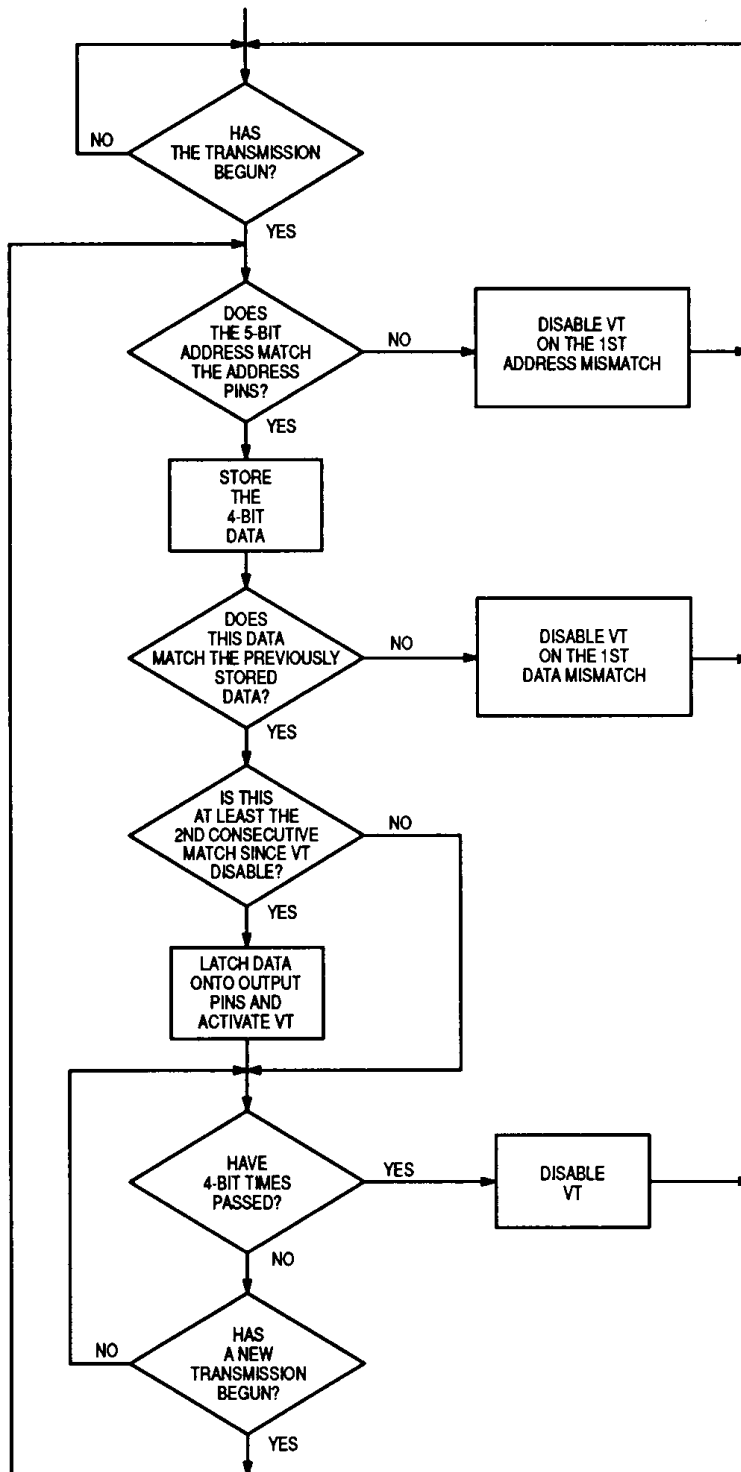


Figure 12. MC145027 Flowchart

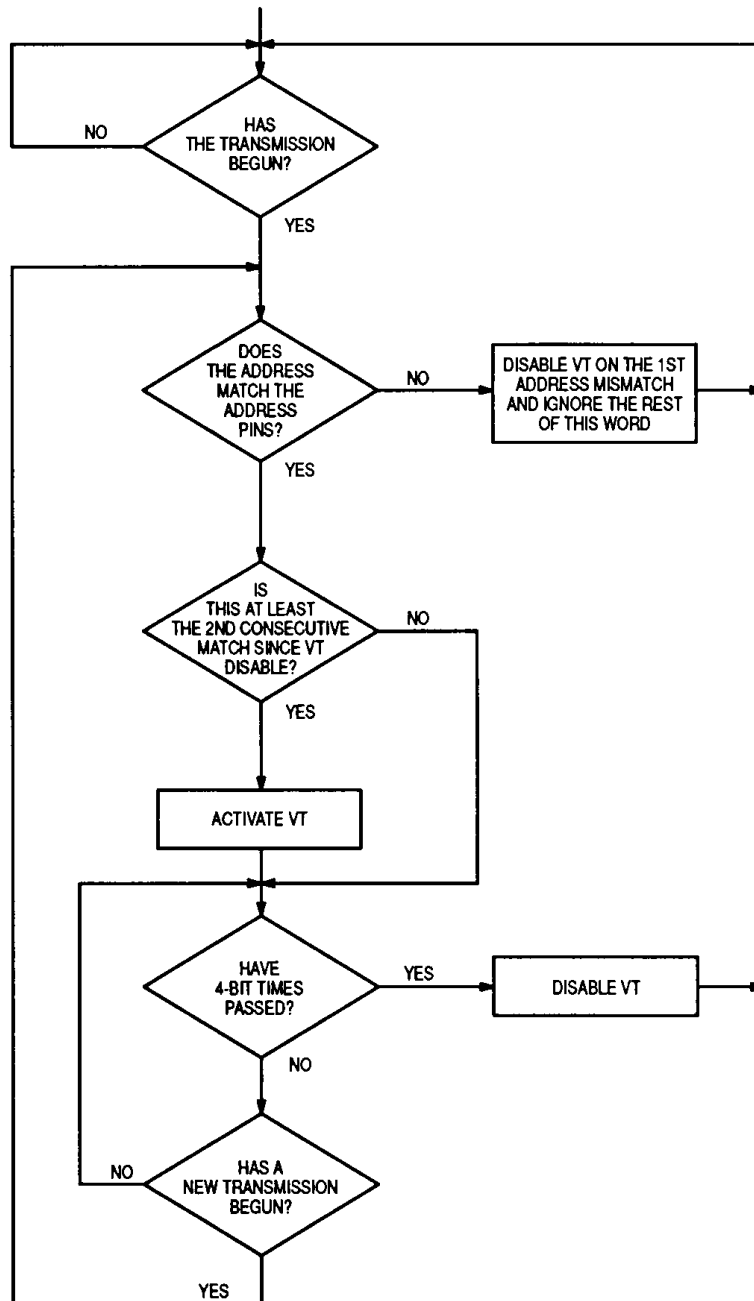
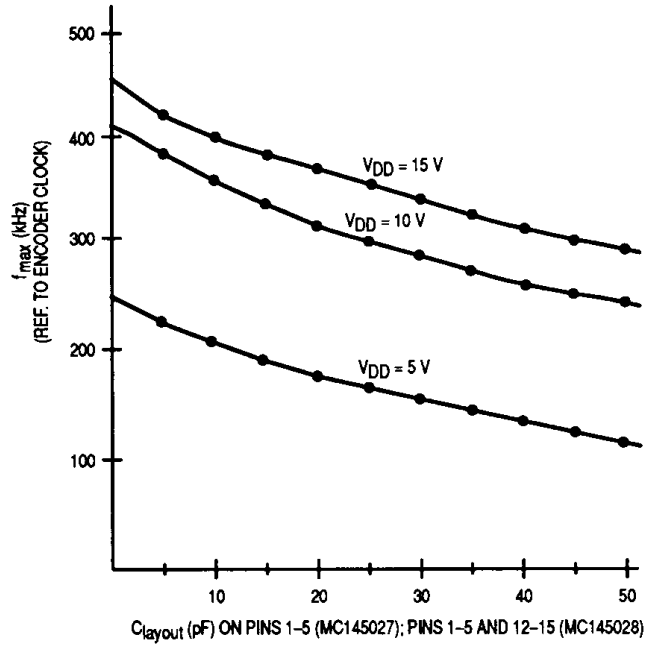


Figure 13. MC145028 Flowchart

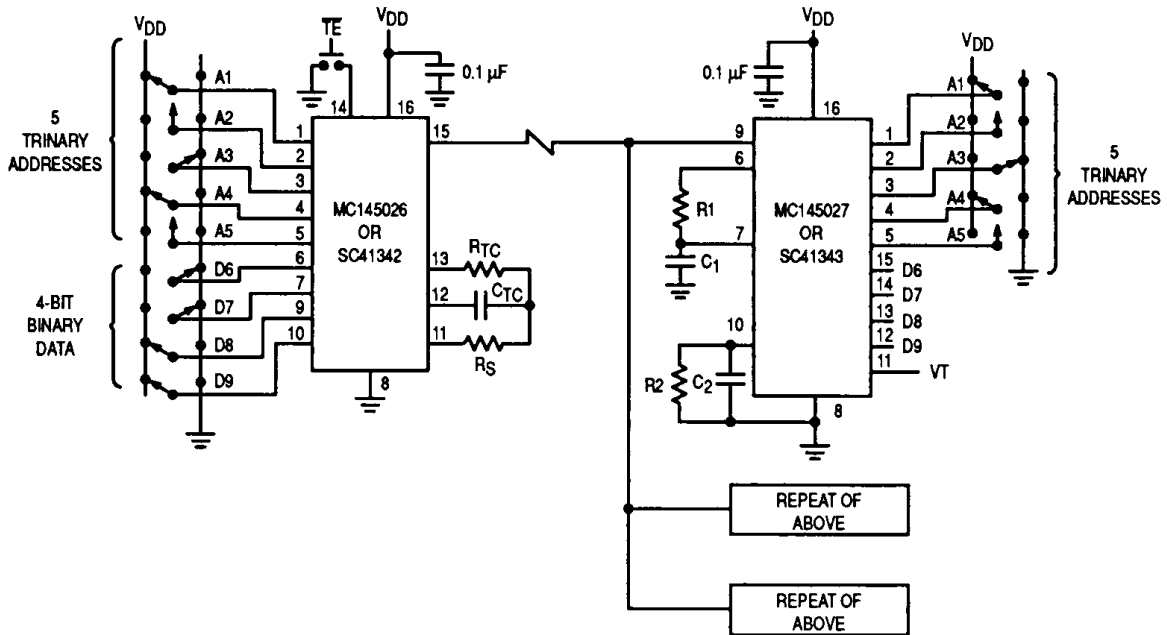
**MC145026•MC145027•MC145028•  
SC41342•SC41343•SC41344**



**Figure 14.  $f_{max}$  vs  $C_{layout}$  — Decoders Only**

**6**

**MC145026•MC145027•MC145028•  
SC41342•SC41343•SC41344**



$$f_{osc} = \frac{1}{2.3 R_{TC} C_{TC}'}$$

$$R_1 C_1 = 3.95 R_{TC} C_{TC}'$$

$$R_2 C_2 = 77 R_{TC} C_{TC}'$$

$C_{TC}' = C_{TC} + C_{layout} + 12 \text{ pF}$   
 $100 \text{ pF} \leq C_{TC} \leq 15 \text{ }\mu\text{F}$   
 $R_{TC} \geq 10 \text{ k}; R_S = 2 R_{TC}$   
 $R_1 \geq 10 \text{ k}$   
 $C_1 \geq 400 \text{ pF}$   
 $R_2 \geq 100 \text{ k}$   
 $C_2 \geq 700 \text{ pF}$

**6**

**Example R/C Values**  
(All Resistors and Capacitors are  $\pm 5\%$ )

( $C_{TC}' = C_{TC} + 20 \text{ pF}$ )

$f_{osc}$ (kHz)	$R_{TC}$	$C_{TC}'$	$R_S$	$R_1$	$C_1$	$R_2$	$C_2$
362	10 k	120 pF	20 k	10 k	470 pF	100 k	910 pF
181	10 k	240 pF	20 k	10 k	910 pF	100 k	1800 pF
88.7	10 k	490 pF	20 k	10 k	2000 pF	100 k	3900 pF
42.6	10 k	1020 pF	20 k	10 k	3900 pF	100 k	7500 pF
21.5	10 k	2020 pF	20 k	10 k	8200 pF	100 k	0.015 $\mu\text{F}$
8.53	10 k	5100 pF	20 k	10 k	0.02 $\mu\text{F}$	200 k	0.02 $\mu\text{F}$
1.71	50 k	5100 pF	100 k	50 k	0.02 $\mu\text{F}$	200 k	0.1 $\mu\text{F}$

**Figure 15. Typical Application**

## APPLICATIONS INFORMATION

### Infrared Transmitter

In Figure 16, the MC145026 encoder is set to run at an oscillator frequency of about 4 kHz to 9 kHz. Thus, the time required for a complete two-word encoding sequence is about 20 ms to 40 ms. The data output from the encoder gates an RC oscillator running at 50 kHz; the oscillator shown starts rapidly enough to be used in this application. When the "send" button is not depressed, both the MC145026 and oscillator are in a low-power standby state. The RC oscillator has to be trimmed for 50 kHz and has some drawbacks for frequency stability. A superior system uses a ceramic resonator oscillator running at 400 kHz. This oscillator feeds a divider as shown in Figure 17. The unused inputs of the MC14011UB must be grounded.

The MLED81 IRED is driven with the 50 kHz square wave at about 200 mA to 300 mA to generate the carrier. If desired, 2 IREDs wired in series can be used. (See Application Note AN1016 for more information.) The bipolar IRED switch shown in Figure 16 offers two advantages over a FET. First, a logic FET has too much gate capacitance for the MC14011UB to drive without waveform distortion. Second, the bipolar drive permits lower supply voltages, which are an advantage in portable battery-powered applications.

The configuration shown in Figure 16 operates over a supply range of 4.5 V to 18 V. A low-voltage system which operates down to 2.5 V could be realized if the SC41342 (the low-voltage version of the MC145026) is used in lieu of the MC145026. The oscillator section of a MC74HC4060 is used in place of the MC14011UB. The data output of the SC41342 is inverted and fed to the reset pin of the MC74HC4060. Alternately, the MC74HCU04 could be used for the oscillator.

Information on the MC14011UB is in book number DL131/D. The MC74HCU04 and MC74HC4060 are found in book number DL129/D.

### Infrared Receiver

The receiver in Figure 18 couples an IR-sensitive diode to input preamp A1, followed by bandpass amplifier A2 with a gain of about 10. Limiting stage A3 follows, with an output of about 800 mVp-p. The limited 50 kHz burst is detected by comparator A4 that passes only positive pulses, and peak-detected and filtered by a diode/RC network to extract the data envelope from the burst. Comparator A5 boosts the signal to logic levels compatible with the MC145027/8 data input. The data in pin of these decoders is a standard CMOS high-impedance input which must NOT be allowed to float. Therefore, direct coupling from A5 to the decoder input is utilized.

Shielding should be used on at least A1 and A2, with good ground and high-sensitivity circuit layout techniques applied.

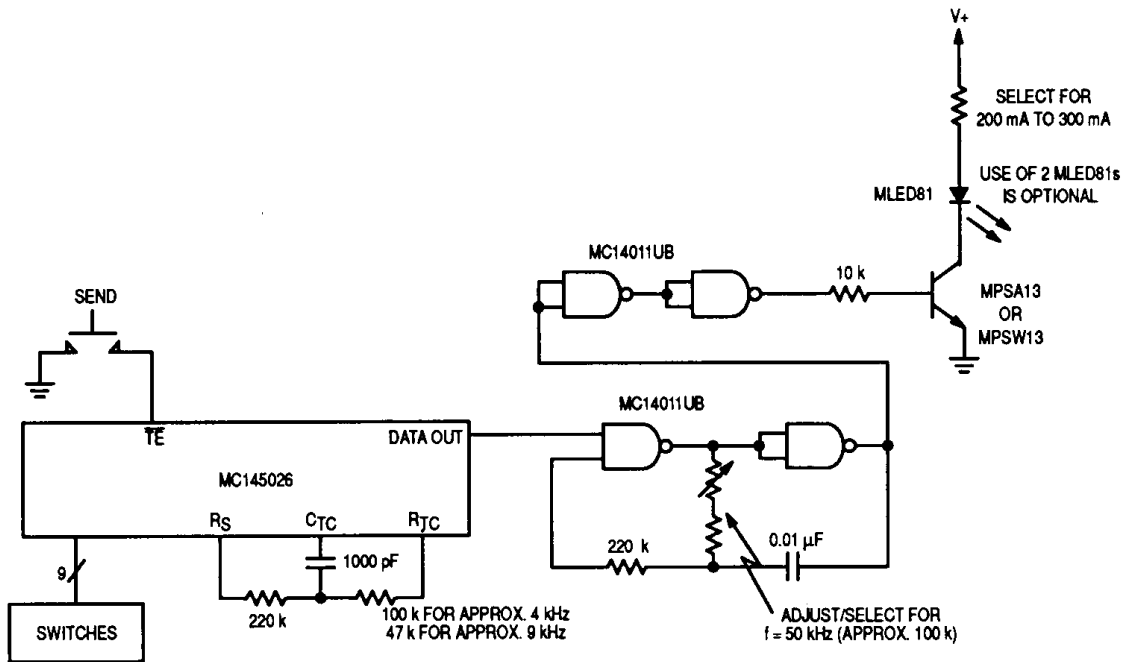
For operation with supplies higher than +5 V, limiter A4's positive output swing needs to be limited to 3 V to 5 V. This is accomplished via adding a zener diode in the negative feedback path, thus avoiding excessive system noise. The biasing resistor stack should be adjusted such that V3 is 1.25 V to 1.5 V.

This system works up to a range of about 10 meters. The gains of the system may be adjusted to suit the individual design needs. The 100  $\Omega$  resistor in the emitter of the first 2N5088 and the 1 k $\Omega$  resistor feeding A2 may be altered if different gain is required. In general, more gain does not necessarily result in increased range. This is due to noise floor limitations. The designer should increase transmitter power and/or increase receiver aperture with fresnel lensing to greatly improve range. See applications note AN1016 for additional information.

Information on the MC34074 is in data book DL128/D.

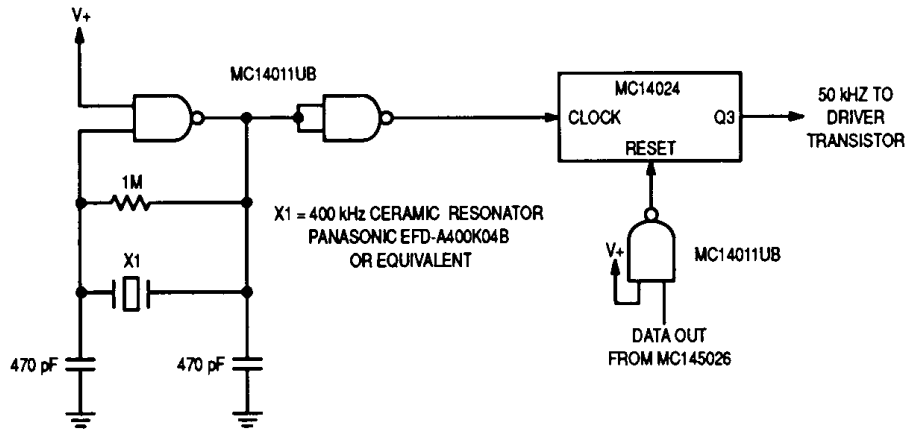


**MC145026•MC145027•MC145028•  
SC41342•SC41343•SC41344**



**Figure 16. IRED Transmitter Using RC Oscillator to Generate Carrier Frequency**

**6**



**Figure 17. Using a Ceramic Resonator to Generate Carrier Frequency**

MC145026•MC145027•MC145028•  
SC41342•SC41343•SC41344

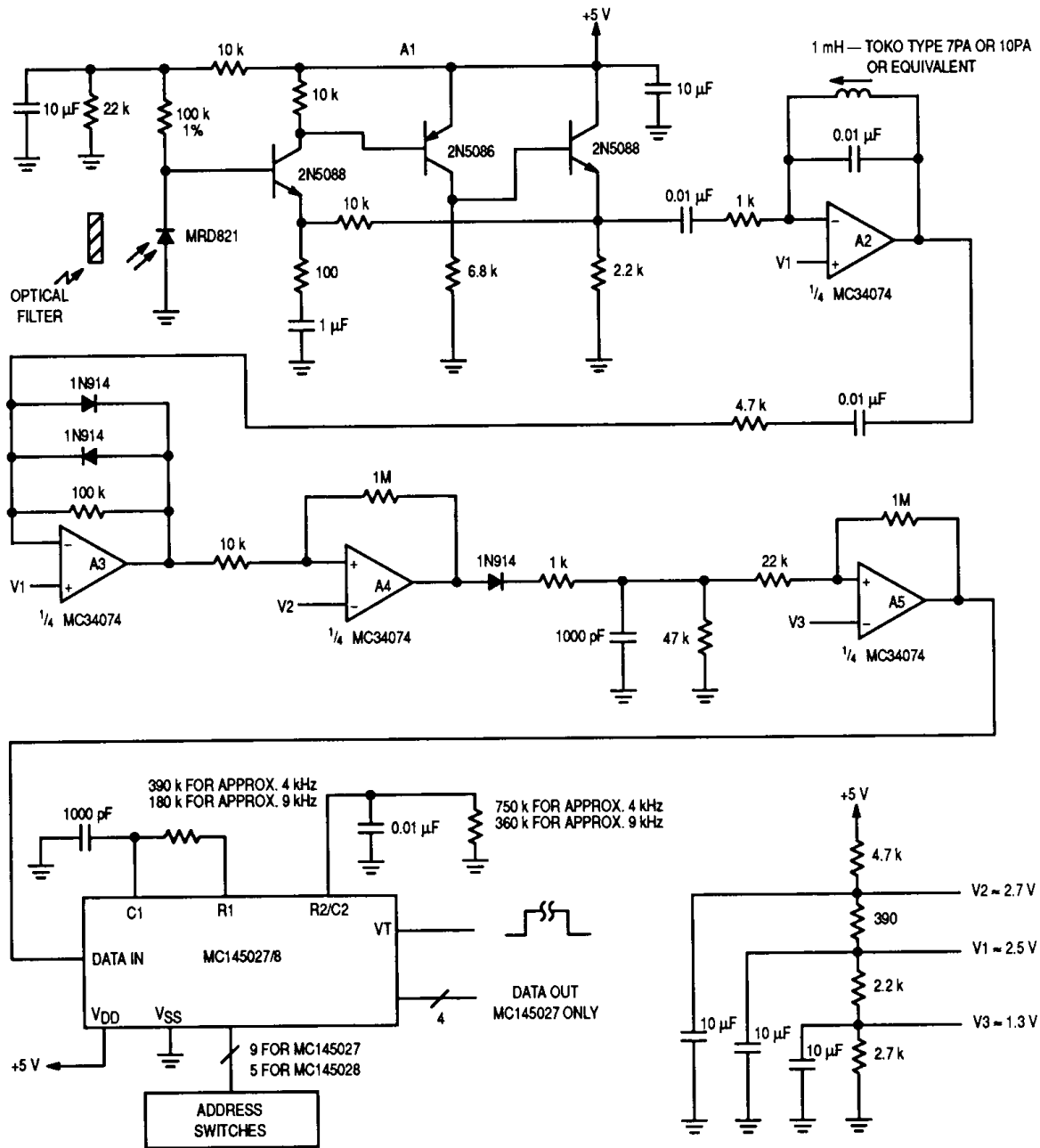


Figure 18. Infrared Receiver

## Remote Control Functions

	Page No.
MC14469    Addressable Asynchronous Receiver/Transmitter .....	6-3
MC14497    PCM Remote Control Transmitter .....	6-11
MC145026   Remote Control Encoder .....	6-17
MC145027   Remote Control Decoder .....	6-17
MC145028   Remote Control Decoder .....	6-17
MC145030   Remote Control Encoder/Decoder .....	6-35
MC145031   Remote Control Encoder .....	6-43
MC145032   Remote Control Decoder .....	6-43
MC145033   Remote Control Encoder/Decoder .....	6-43
MC145034   Remote Control Encoder .....	6-43
MC145035   Remote Control Decoder .....	6-43

### SELECTOR GUIDE

Function	Number of Address Lines	Maximum Number of Address Codes	Number of Data Bits	Operation	Device Number
Addressable UART	7	128	7/8	Full Duplex	<b>MC14469</b>
Transmitter	0	0	6	Simplex	<b>MC14497</b>
Encoder	Depends on Decoder	Depends on Decoder	Depends on Decoder	Simplex	<b>MC145026</b>
Decoder	5	243	4	Simplex	<b>MC145027</b>
Decoder	9	19,683	0	Simplex	<b>MC145028</b>
Encoder/Decoder	9	512	0	Half Duplex	<b>MC145030</b>
Encoder	13 or 17	131,072	4	Simplex	<b>MC145031</b> <b>MC145034</b>
Decoder	13 or 17	131,072	4	Simplex	<b>MC145032</b> <b>MC145035</b>
Encoder/Decoder	15	32,768	0	Half Duplex	<b>MC145033</b>

6