

TLRE20T, TLRME20T, TLSE20T, TLOE20T, TLYE20T

PANEL CIRCUIT INDICATOR

Unit in mm

- 5 mm Package
- InGaAlP Technology
- All Plastic Mold Type
- Transparent Lens
- High Intensity Light Emission
- Excellent Low Current Light Output
- Applications: Outdoor Message Signboards, Safety equipment

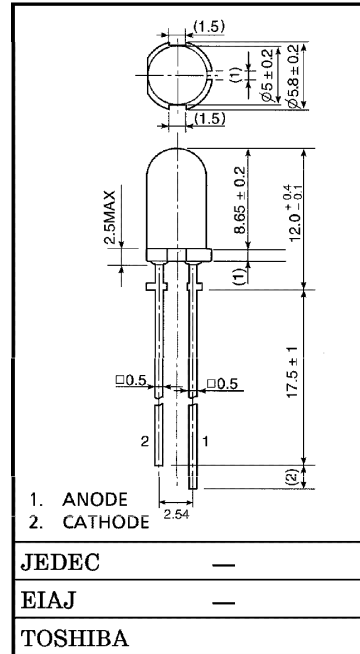

Weight : 0.31 g

LINE-UP

PRODUCT NAME	COLOR	MATERIAL
TLRE20T	Red	InGaAlP
TLRME20T	Red	
TLSE20T	Red	
TLOE20T	Orange	
TLYE20T	Yellow	

MAXIMUM RATINGS (Ta = 25°C)

PRODUCT NAME	FORWARD CURRENT I _F (mA)	REVERSE VOLTAGE V _R (V)	POWER DISSIPATION P _D (mW)	OPERATING TEMPERATURE T _{opr} (°C)	STORAGE TEMPERATURE T _{stg} (°C)
TLRE20T	50	4	120	-40~100	-40~120
TLRME20T	50	4	120	-40~100	-40~120
TLSE20T	50	4	120	-40~100	-40~120
TLOE20T	50	4	120	-40~100	-40~120
TLYE20T	50	4	120	-40~100	-40~120

961001EAC1

- TOSHIBA is continually working to improve the quality and the reliability of its products. Nevertheless, semiconductor devices in general can malfunction or fail due to their inherent electrical sensitivity and vulnerability to physical stress. It is the responsibility of the buyer, when utilizing TOSHIBA products, to observe standards of safety, and to avoid situations in which a malfunction or failure of a TOSHIBA product could cause loss of human life, bodily injury or damage to property. In developing your designs, please ensure that TOSHIBA products are used within specified operating ranges as set forth in the most recent products specifications. Also, please keep in mind the precautions and conditions set forth in the TOSHIBA Semiconductor Reliability Handbook.
- Gallium arsenide (GaAs) is a substance used in the products described in this document. GaAs dust and fumes are toxic. Do not break, cut or pulverize the product, or use chemicals to dissolve them. When disposing of the products, follow the appropriate regulations. Do not dispose of the products with other industrial waste or with domestic garbage.
- The information contained herein is presented only as a guide for the applications of our products. No responsibility is assumed by TOSHIBA CORPORATION for any infringements of intellectual property or other rights of the third parties which may result from its use. No license is granted by implication or otherwise under any intellectual property or other rights of TOSHIBA CORPORATION or others.
- The information contained herein is subject to change without notice.

2000-02-29 1/7

ELECTRICAL AND OPTICAL CHARACTERISTICS (Ta = 25°C)

PRODUCT NAME	TYP. EMISSION WAVELENGTH				LUMINOUS INTENSITY I _V			FORWARD VOLTAGE V _F			REVERSE CURRENT I _R	
	λ _d	λ _p	Δλ	I _F	MIN	TYP.	I _F	TYP.	MAX	I _F	MAX	V _R
TLRE20T	630	(644)	20	20	2720	7000	20	1.9	2.4	20	50	4
TLRME20T	626	(636)	23	20	2720	8000	20	1.9	2.4	20	50	4
TLSE20T	613	(623)	20	20	2720	9000	20	1.9	2.4	20	50	4
TLOE20T	605	(612)	20	20	4760	10000	20	2.0	2.4	20	50	4
TLYE20T	587	(590)	17	20	2720	9500	20	2.0	2.4	20	50	4
Unit	nm			mA	mcd		mA	V		mA	μA	V

PRECAUTIONS

Please be careful of the following:

- Soldering temperature: 260°C max, soldering time: 3 s max (soldering portion of lead: below the lead stopper)
- If the lead is formed, the lead should be formed up to 5 mm from the body of the device without forming stress to the resin. Soldering should be performed after lead forming.
- This visible LED lamp also emits some IR light. If a photodetector is located near the LED lamp, please ensure that it will not be affected by this IR light.

TLRE20T

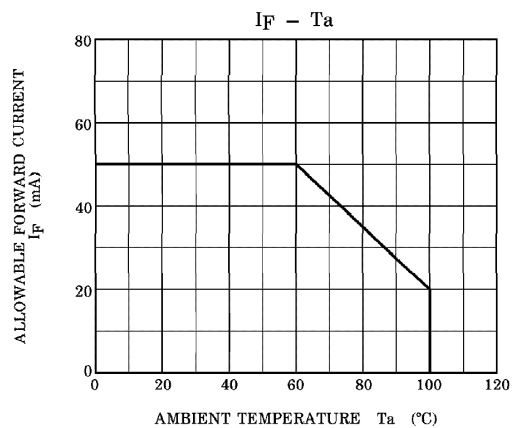
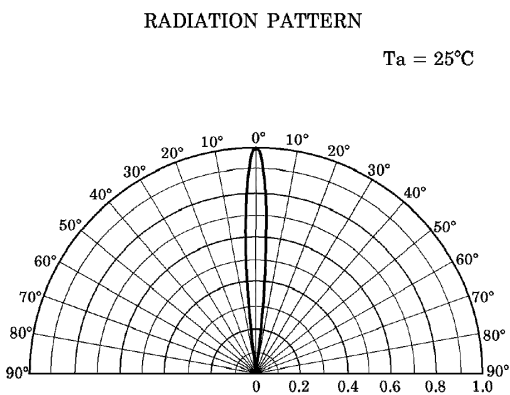
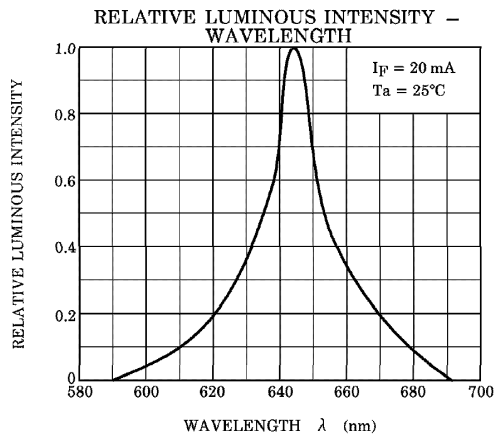
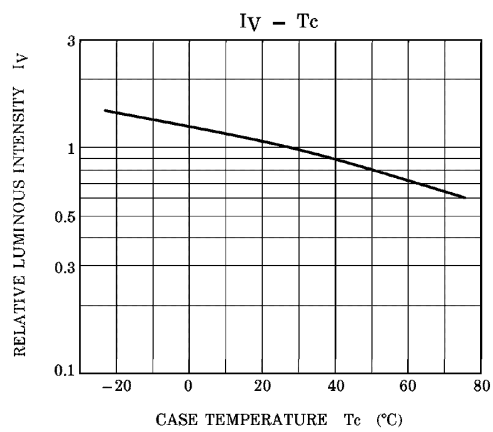
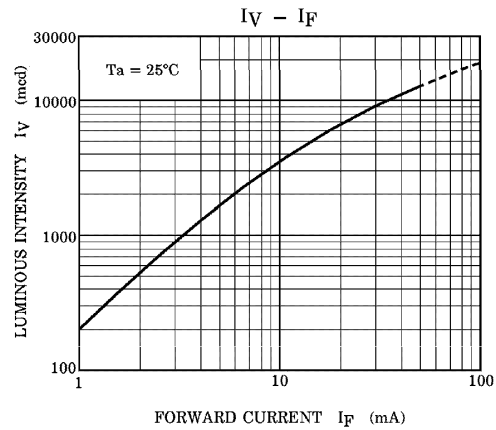
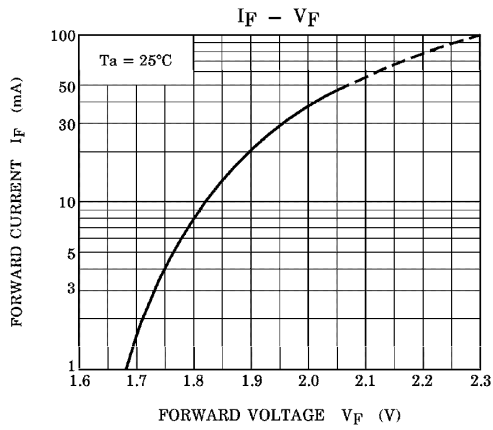

TLRME20T

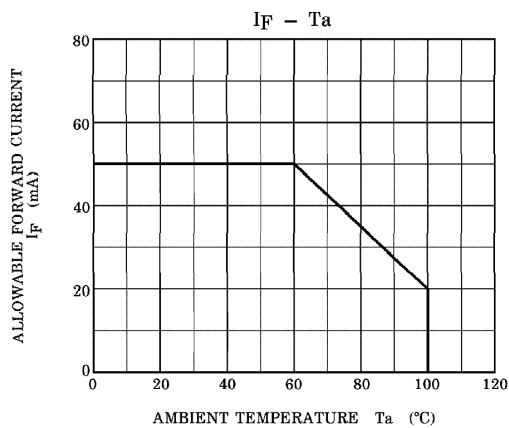
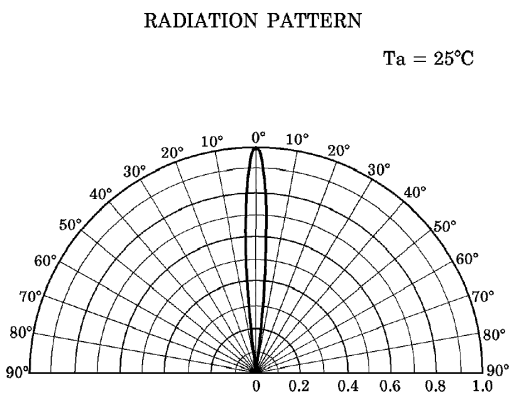
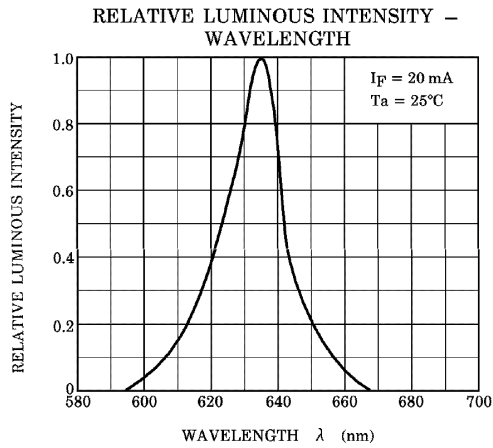
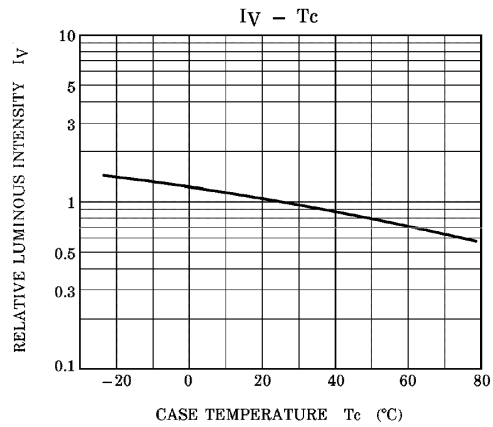
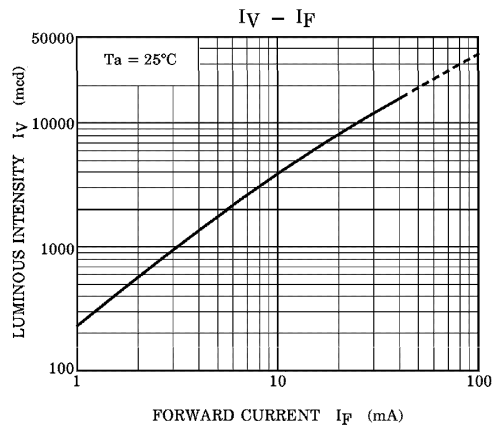
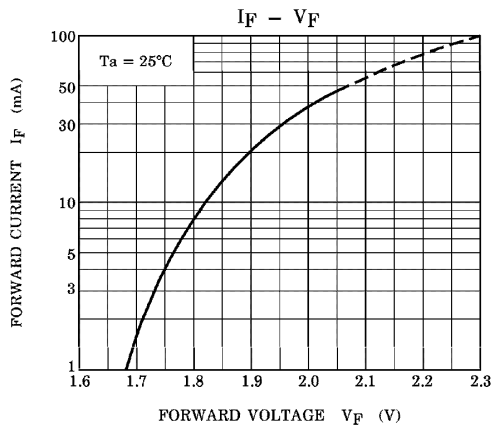

TLSE20T

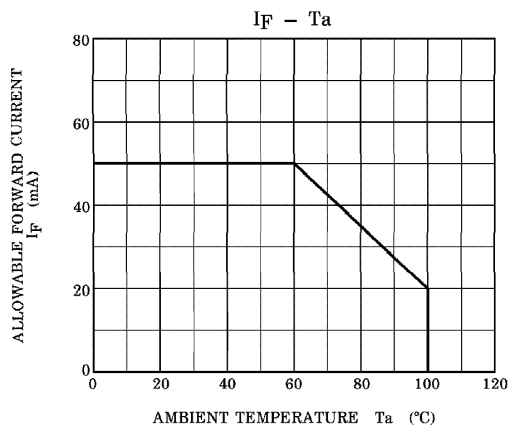
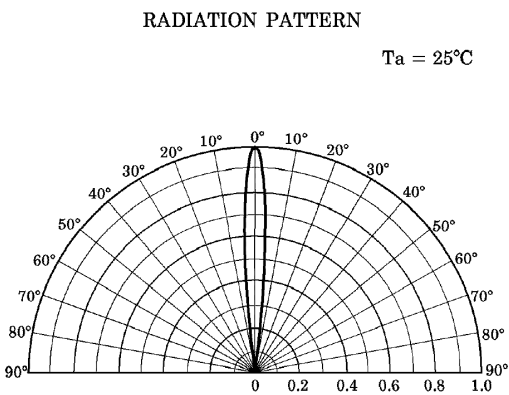
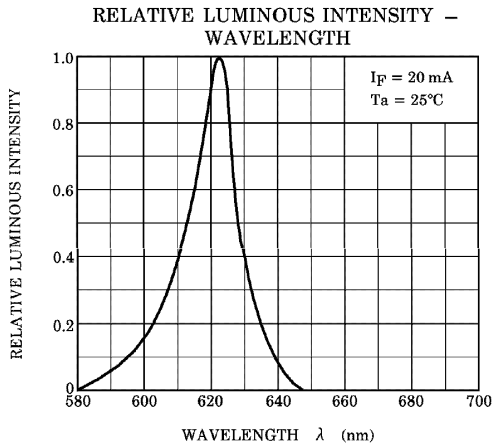
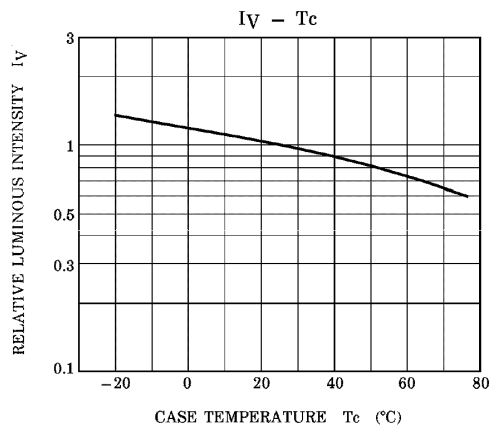
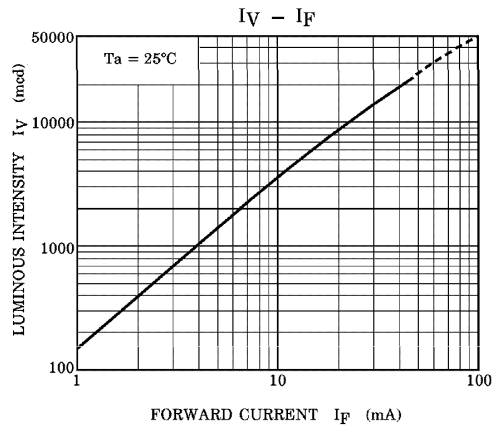
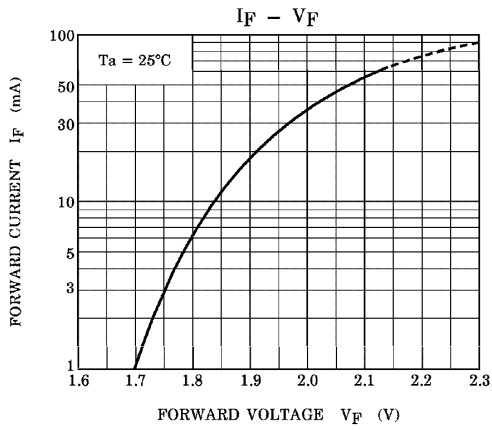

TLOE20T

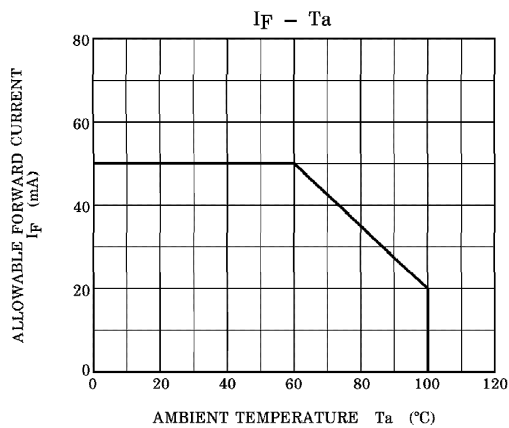
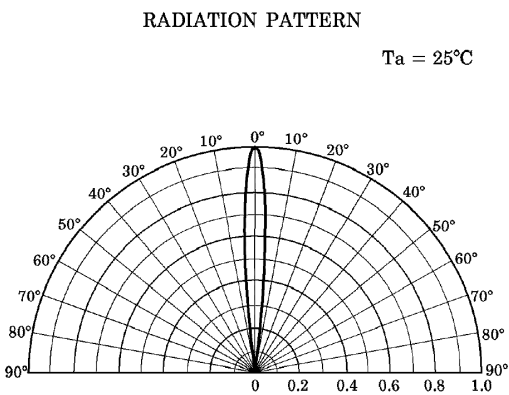
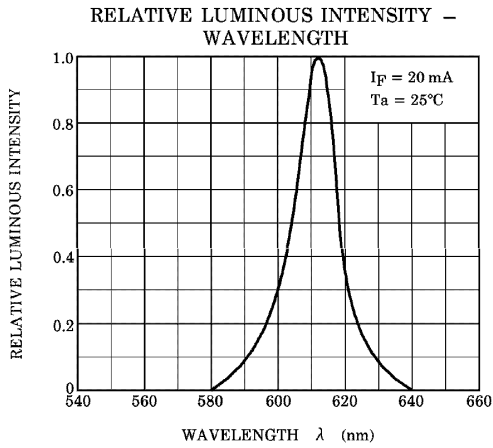
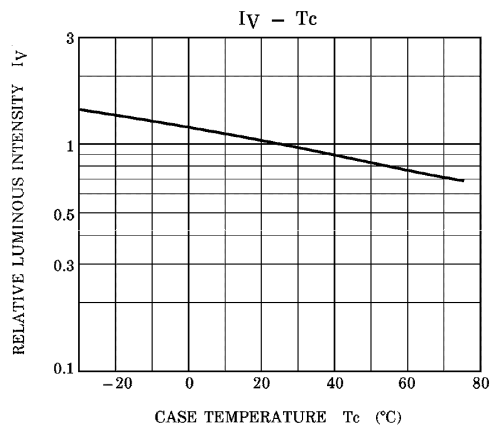
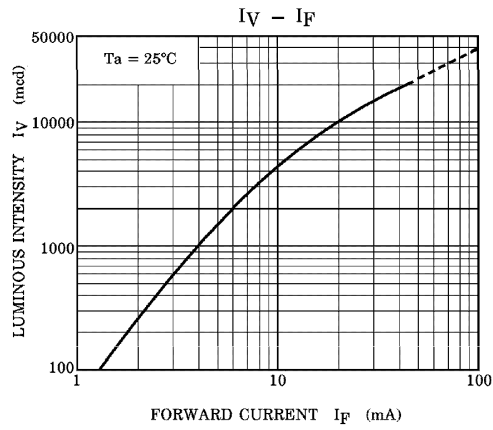
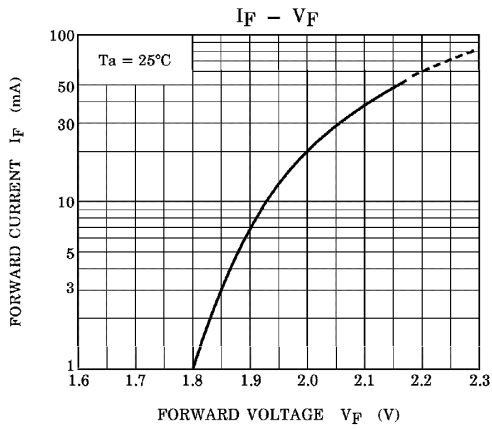

TLYE20T

