

Silicon Controlled Rectifier Series 080

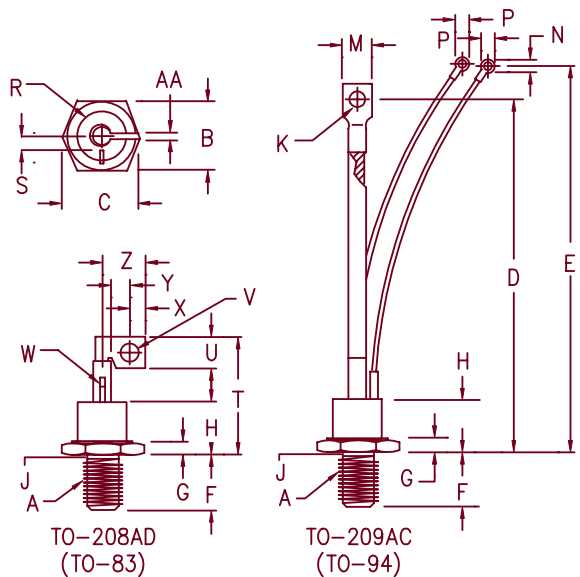

- Note 1: 1/2-20 UNF-3A
 Note 2: Full thread within 2 1/2 threads
 Note 3: To specify package designation other than standard lead enter appropriate letter in place of "A".
 "B" = Insulated lead
 "D" = Flag Terminal
 "C" = Top Stud (consult factory)

Dim.	Inches		Millimeter		Notes
	Minimum	Maximum	Minimum	Maximum	
A	---	---	---	---	1
B	1.050	1.060	26.67	26.92	
C	---	1.161	---	29.49	
D	5.850	6.144	149.10	156.06	
E	6.850	7.375	173.99	187.33	
F	.797	.827	20.24	21.01	
G	.276	.286	.701	7.26	
H	---	.948	---	24.08	
J	.425	.499	10.80	12.67	2
K	.260	.280	6.60	7.11	Dia.
M	.500	.600	12.70	15.24	
N	.140	.150	3.56	3.81	
P	---	.295	---	7.49	
R	---	.900	---	22.86	Dia.
S	.225	.275	6.48	6.99	
T	---	1.750	---	44.45	
U	.370	.380	9.40	9.65	
V	.213	.223	5.41	5.66	Dia.
W	.065	.075	1.65	1.91	Dia.
X	.215	.225	5.46	5.72	
Y	.290	.315	7.37	8.00	
Z	.514	.530	13.06	13.46	
AA	.089	.099	2.26	2.51	

Microsemi Catalog Number	Forward & Reverse Repetitive Blocking	Reverse Transient Blocking
Standard Lead		
08003GOA	300	400
08004GOA	400	500
08005GOA	500	600
08006GOA	600	700

To specify dv/dt higher than 200V/usec., contact factory.

- High dv/dt—200 V/usec.
- 1800 Amperes surge current
- Low forward on-state voltage
- Package conforming to either TO-209AC or TO-208AD outline
- Economical for general purpose phase control applications

Electrical Characteristics		
Max. RMS on-state current	$I_{T(RMS)}$ 125 Amps	$T_C = 87^\circ C$
Max. average on-state cur.	$I_{T(AV)}$ 80 Amps	$T_C = 87^\circ C$
Max. peak on-state voltage	V_{TM} 1.4 Volts	$I_{TM} = 220 \text{ A(peak)}$
Max. holding current	I_H 200 mA	
Max. peak one cycle surge current	I_{TSM} 1800 A	$T_C = 87^\circ C, 60 \text{ Hz}$
Max. I^2t capability for fusing	I^2t 13,500A ² S	$t = 8.3 \text{ ms}$

Thermal and Mechanical Characteristics		
Operating junction temp range	T_J	-65°C to 125°C
Storage temperature range	T_{STG}	-65°C to 150°C
Maximum thermal resistance	$R_{\theta JC}$	0.40°C/W Junction to case
Typical thermal resistance (greased)	$R_{\theta CS}$	0.20°C/W Case to sink
Mounting torque		100-130 inch pounds
Weight		080-GOA Approx. 3.6 ounces (102.0 grams) typical 080-GOD Approx. 3.24 ounces (91.8 grams) typical

080

Switching

Critical rate of rise of on-state current (note 1)	di/dt	100A/usec.	$T_J = 125^\circ\text{C}$
Typical delay time (note 1)	t_d	3.0 usec.	
Typical circuit commuted turn-off time (note 2)	t_q	100 usec.	$T_J = 125^\circ\text{C}$

Note 1: $I_{TM} = 50\text{A}$, $V_D = V_{DRM}$, $V_{GT} = 12\text{V}$ open circuit, 20 ohm-0.1 usec. rise time

Note 2: $I_{TM} = 50\text{A}$, $di/dt = 5\text{A/usec.}$, V_R during turn-off interval = 50V min.,
reapplied $dv/dt = 20\text{V/usec.}$, linear to rated V_{DRM} , $V_{GT} = 0\text{V}$

Triggering

Max. gate voltage to trigger	V_{GT}	3.0V	$T_J = 25^\circ\text{C}$
Max. nontriggering gate voltage	V_{GD}	0.25V	$T_J = 125^\circ\text{C}$
Max. gate current to trigger	I_{GT}	100mA	$T_J = 25^\circ\text{C}$
Max. peak gate power	P_{GM}	15W	
Average gate power	$P_{G(AV)}$	3.0W	$t_p = 10 \text{ usec.}$
Max. peak gate current	I_{GM}	4.0A	
Max. peak gate voltage (forward)	V_{GM}	10V	
Max. peak gate voltage (reverse)	V_{GM}	5.0V	

Blocking

Max. leakage current	I_{DRM}	10mA	$T_J = 125^\circ\text{C} \ \& \ V_{DRM}$
Max. reverse leakage	I_{RRM}	10mA	$T_J = 125^\circ\text{C} \ \& \ V_{RRM}$
Critical rate of rise of off-state voltage	dv/dt	200V/usec.	$T_J = 125^\circ\text{C}$

Figure 1
Typical Forward On-State Characteristics

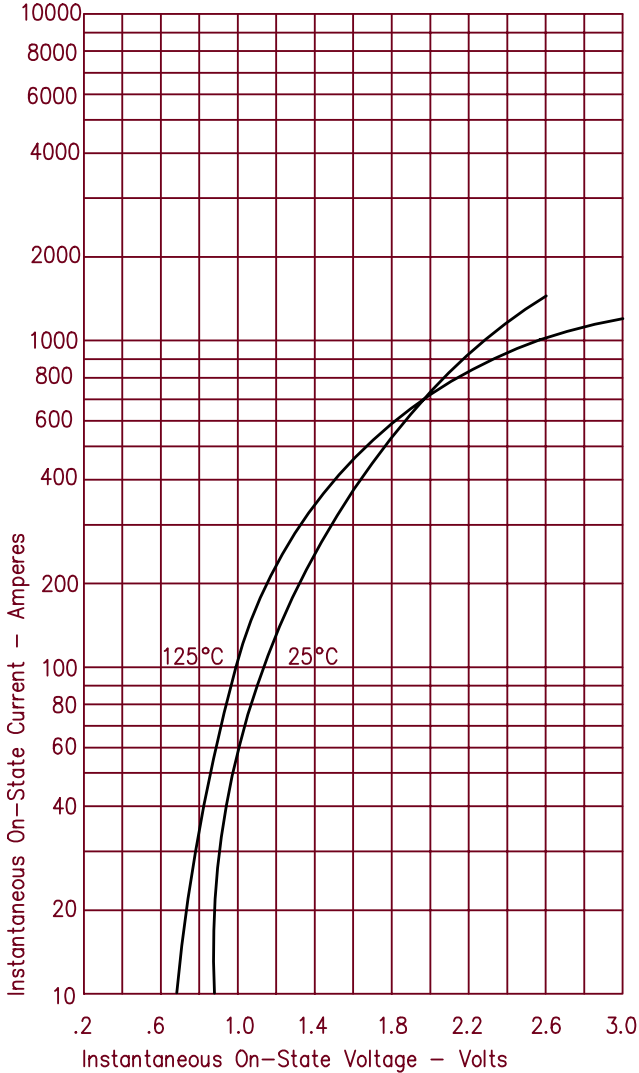

Figure 3
Maximum Power Dissipation

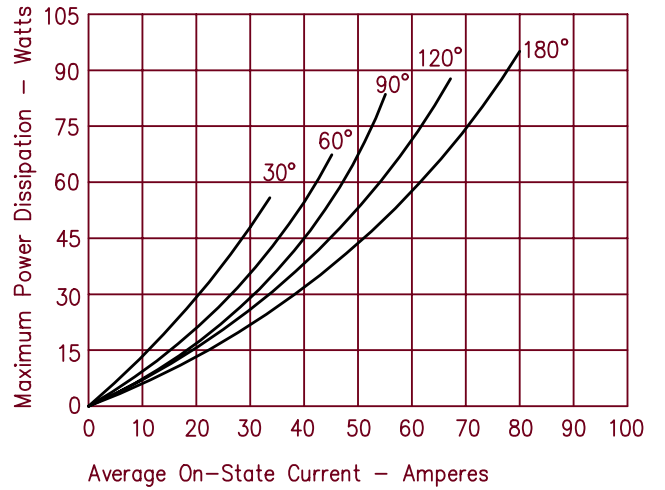

Figure 4
Transient Thermal Impedance

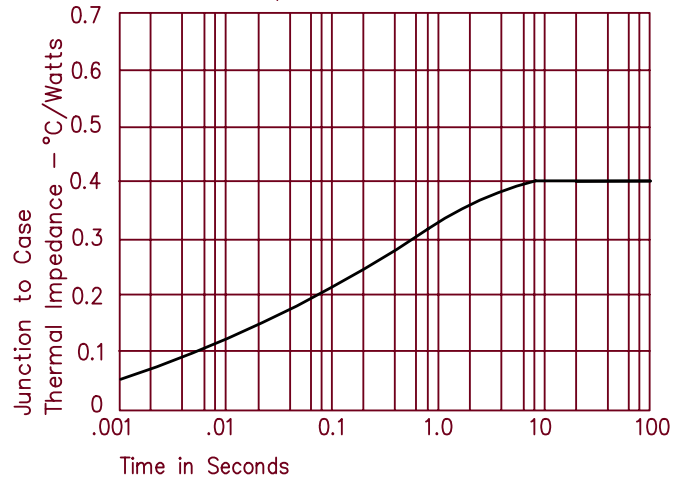

Figure 2
Forward Current Derating

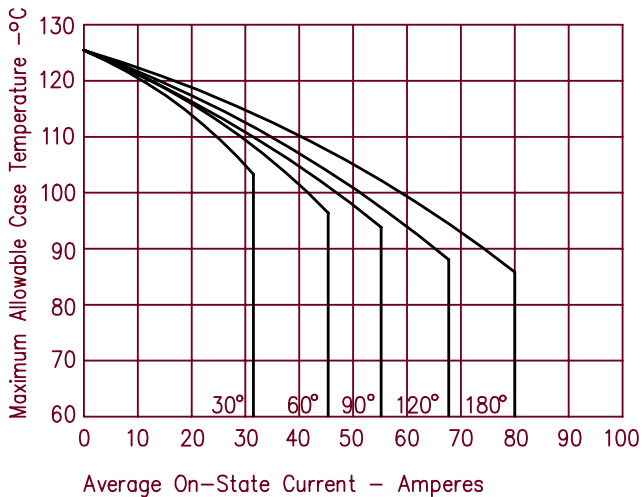

Figure 5
Maximum Nonrepetitive Surge Current

