

# Single Phase Bridge Modules EH60, EH75

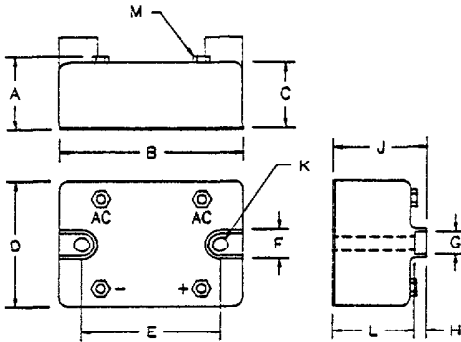

Dim.	Inches		Millimeter		Notes
	Minimum	Maximum	Minimum	Maximum	
A	—	1.10	—	27.94	
B	2.25	2.40	57.15	60.96	
C	.930	.950	23.62	24.13	
D	1.740	1.760	44.19	44.70	
E	1.883	1.887	47.82	47.92	
F	.495	.505	12.57	12.83	
G	.325	.335	8.25	8.50	
H	.215	.225	5.46	5.71	
J	1.270	1.300	32.25	33.02	
K	.198	.208	5.02	5.28	Dia.
L	1.055	1.075	26.79	27.30	
M	#10-32 Tapped Holes				

E

Microsemi Catalog Number	Repetitive Peak Reverse Voltage
EH6002B*	200
EH6004B*	400
EH6006B*	600
EH6008B*	800
EH6010B*	1000
EH6012B*	1200
EH7502B*	
EH7504B*	
EH7506B*	
EH7508B*	
EH7510B*	
EH7512B*	

\*Add S for Transient Suppressor across output

- Integral Transient Suppression Available
- High Terminal-to-base Isolation of 2500VAC RMS
- Available to 1200V
- Mounting Bolts Isolated From Power Terminals

Electrical Characteristics				
		EH60	EH75	
Maximum DC output current, single phase	$I_o$	60A	75A	Sine wave, 180° conduction
Maximum case temperature	$T_c$	104°C	105°C	
Maximum surge current per diode	$I_{FSM}$	1050A	1500A	8.3ms, half sine, $T_J = 175^\circ\text{C}$
Max. $I_{2t}$ for fusing	$I_{2t}$	4600A <sup>2</sup> S	9300A <sup>2</sup> S	
Max. peak forward voltage per diode	$V_{FM}$	1.2V	1.1V	• $I_o$ : $T_J = 25^\circ\text{C}$
Max. peak reverse voltage per diode	IRM	4mA	—	VRRM, $T_J = 150^\circ\text{C}$
Minimum isolation voltage	VSOL	2500VRMS		any terminal-to-base

Thermal and Mechanical Characteristics		
Storage temp range	$T_{STG}$	-40°C to 175°C
Operating junction temp range	$T_J$	-40°C to 175°C
Max thermal resistance per diode	EH60 R $\theta$ JC	1.0°C/W Junction to case
	EH75 R $\theta$ JC	0.85°C/W Junction to case
Max mounting torque		30 lb-in
Typical thermal resistance	R $\theta$ CS	0.07°C/W Case to sink
Typical Weight		5.8 ounces (165 grams)

**Microsemi Corp.**  
**Colorado**

PH: 303-469-2161  
FAX: 303-466-3775

# EH60, EH75

Figure 1  
Typical Forward Characteristics - Per Diode

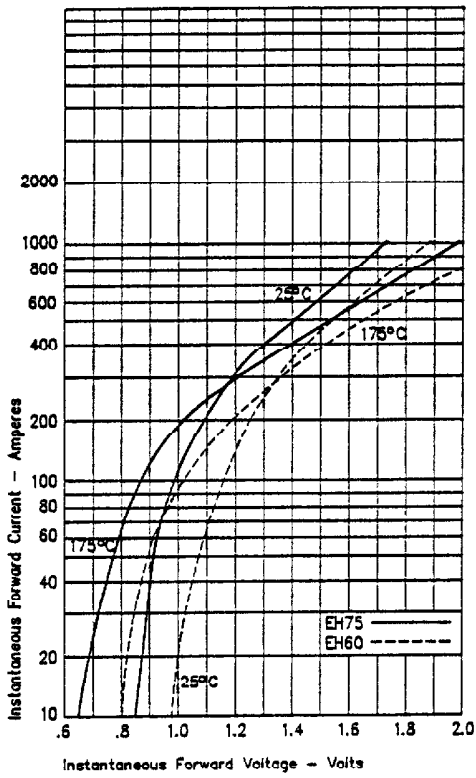

Figure 3  
Maximum Nonrepetitive Surge Current - Per Diode

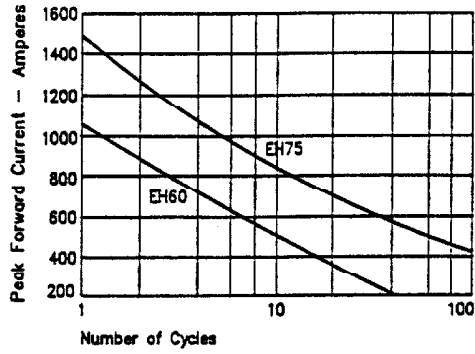

Figure 2  
Forward Current Derating - Per Diode

