

DESCRIPTION

The Quad Output Module Ideal for Desktop and Industrial Applications. The LXM1640 Direct Drive™ Cold Cathode Fluorescent Lamp (CCFL) Inverter is a single module designed to drive four lamps and is targeted for use with desktop Liquid Crystal Display (LCD) and industrial LCD panels typically ranging in size from 14-inches to 21-inches. This four output inverter is the ideal solution to power virtually any four lamp application.

Direct Drive Technology. The module design is based on a new Direct Drive topology, which provides a number of cost and performance advantages. The LXM1640-01 Direct Drive inverters eliminate the classic resonant inductor and capacitors, thus reducing cost and allowing a substantial reduction in module size.

Fixed-Frequency Operation. Other benefits of this new topology are fixed-frequency operation and secondary-side strike-voltage regulation. Strike-voltage regulation minimizes corona discharge in the output transformer and related circuitry, providing longer life and higher reliability.

Fail-safe Feature For Multiple Lamp Applications. Our multi-output inverters are designed to keep your application op-

erating at near normal brightness in the event that a lamp fails. This allows the display to remain "on-line" until lamp replacement is convenient.

Quad Module Uses Standard Power Supply. The LXM1640 module uses a standard 12V input supply. It also ensures nominal power consumption with 4 lamps requiring only 16 watts. Lamp current is fully regulated with respect to input voltage and output impedance variations.

Dimming Features. The LXM1640 modules are equipped with a dimming input that permits brightness control from an external potentiometer or DC voltage. In addition, the sleep input reduces module power to a few microwatts in shut down mode. All LXM1640 modules feature both output open and short-circuit protection.

The Most Efficient and Cost-effective Backlight Inverter for Desktop/Industrial Applications. Linfinity's proprietary Direct Drive architecture is the highest efficiency, small form factor solution for all multiple lamp applications. The LXM1640 is fully customizable (electronically and mechanically) to specific customer requirements.

KEY FEATURES

- Drive Four Lamps With One Module
- Small, Compact Size
- High Efficiency
- Multiple Output Connectors Provide Easy LCD Connections
- Low EMI And Noise
- Low Power Sleep Mode
- Output Short And Open Circuit Protection
- 3:1 Dimming Control
- Adjustable Lamp Current Up To 6.0mA Per Lamp
- Long Lamp Life With Soft-Start And Accurate Lamp Current Regulation

APPLICATIONS

- Desktop LCD Monitors And Panels
- Industrial LCD Panels
- Hi-Brite Displays

BENEFITS

- Cool Operation
- Smooth, Easy-To-Use Brightness Control
- Single 12 Volt Supply

IMPORTANT: For the most current data, consult Linfinity's web site: <http://www.linfinity.com>.

PRODUCT HIGHLIGHT

LXM1640 "UNIVERSAL" MODULE CONNECTION OPTIONS

Quad Connector Configuration

Dual Connector Configuration

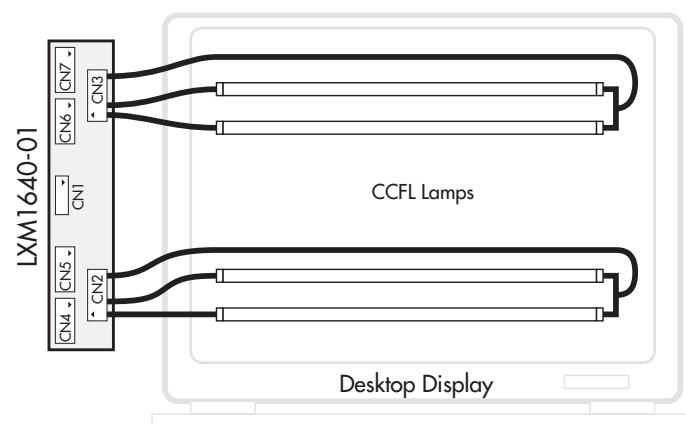
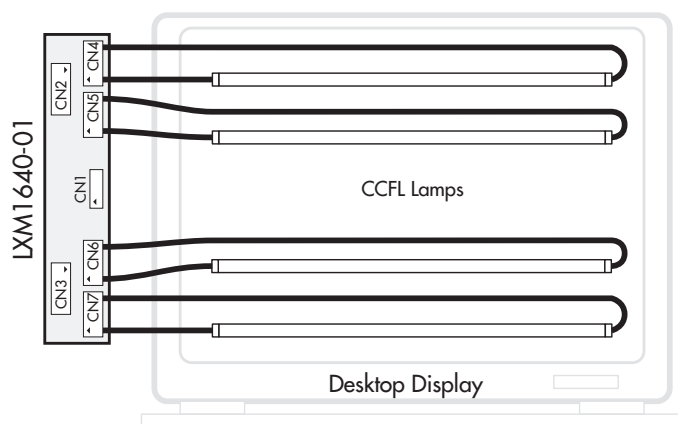

MODULE ORDER INFORMATION

LXM1640-01

LXM1640-01

DIRECT DRIVE QUAD LAMP CCFL INVERTER MODULE

PRELIMINARY DATA SHEET

ABSOLUTE MAXIMUM RATINGS (Note 1)

Input Supply Voltage (V_{IN}).....	-0.3V to 16V
Output Voltage, no load	Internally Limited to 1800V _{RMS}
Output Current (per Lamp)	10.0mA _{RMS} (Internally Limited)
Output Power (per Lamp)	6.0W
Input Signal Voltage, (SLEEP and BRITE Inputs)	-0.3V to V_{IN}
Ambient Operating Temperature, zero airflow	0°C to 40°C
Storage Temperature Range	-40°C to 85°C

Note 1. Exceeding these ratings could cause damage to the device. All voltages are with respect to Ground. Currents are positive into, negative out of the specified terminal.

RECOMMENDED OPERATING CONDITIONS (R.C.)

This module has been designed to operate over a wide range of input and output conditions. However, best efficiency and performance will be obtained if the module is operated under the condition listed in the 'R.C.' column. Min. and Max. columns indicate values beyond which the inverter, although operational, will not function optimally.

Parameter	Symbol	Recommended Operating Conditions			Units
		Min.	R.C.	Max.	
Input Supply Voltage Range (Functional)	V_{IN}	10.8	12	13.2	V
Output Power (per Lamp)	P_O		4	5	W
Brightness Control Input Voltage Range	$V_{BRT\ ADJ}$	0.0		5.0	V
Lamp Operating Voltage	V_{LAMP}	300	675	800	V _{RMS}
Lamp Current (Full Brightness - per Lamp)	I_{OLAMP}		6.0		mA _{RMS}
Operating Ambient Temperature Range	T_A	0		40	°C

ELECTRICAL CHARACTERISTICS

Unless otherwise specified, these specifications apply over the recommended operating conditions and 25°C ambient temperature for the LXM1640.

Parameter	Symbol	Test Conditions	LXM1640-01			Units
			Min.	Typ.	Max.	
Output Pin Characteristics						
Full Bright Lamp Current (per Lamp)	$I_{L(MAX)}$	$V_{BRT\ ADJ} = 5.0V_{DC}$, SLEEP = HIGH, $V_{IN} = 12V_{DC}$	5.4	6.0	6.6	mA _{RMS}
Minimum Lamp Current (per Lamp) (Note 2)	$I_{L(MIN)}$	$V_{BRT\ ADJ} = 0V_{DC}$, SLEEP = HIGH, $V_{IN} = 12V_{DC}$		0.5		mA _{RMS}
Lamp Start Voltage	V_{LS}	0°C < T_A < 40°C, $V_{IN} \geq 10.8V_{DC}$	1500		1800	V _{RMS}
Operating Frequency	f_O	$V_{BRT\ ADJ} = 5.0V_{DC}$, SLEEP = HIGH, $V_{IN} = 12V_{DC}$	52	57	62	KHz
BRITE Input						
Input Current	I_{BRT}	$V_{BRT\ ADJ} = 0V_{DC}$	27	30	33	µA _{DC}
Input Voltage for Max. Lamp Current	V_C	$I_{O(LAMP)} = 100\%$		5.0		V _{DC}
Input Voltage for Min. Lamp Current	V_C	$I_{O(LAMP)} = \text{Minimum}$		0		V _{DC}
SLEEP Input						
RUN Mode	$V_{SLEEP(HI)}$		2.2		V_{IN}	V _{DC}
SLEEP Mode	$V_{SLEEP(LO)}$		-0.3		0.8	V _{DC}
Input Current	I_{SLEEP}	SLEEP = 5.0V	90	110	150	µA _{DC}
Power Characteristics						
Sleep Current	$I_{IN(MIN)}$	$V_{IN} = 12V_{DC}$, SLEEP = 0V _{DC}	0	10	500	µA _{DC}

Note 2. Minimum lamp current required to maintain even light output may vary with display panel.

DIRECT DRIVE QUAD LAMP CCFL INVERTER MODULE

PRELIMINARY DATA SHEET

FUNCTIONAL PIN DESCRIPTION

Conn.	Pin	Description
CN1		
CN1-1 CN1-2	V_{IN}	Input Power Supply. ($10.8V \leq V_{IN} \leq 13.2V$)
CN1-3 CN1-4	GND	Power Supply Return.
CN1-5	\overline{SLEEP}	ON/OFF Control. ($2.2V < \overline{SLEEP} < V_{IN} = ON$, $-0.3V < \overline{SLEEP} < 0.8V = OFF$)
CN1-6	BRITE	Brightness Control ($-0.3V$ to $5.0V_{DC}$). $5.0V_{DC}$ gives maximum lamp current.
CN1-7	N.C.	No Connect.
CN1-8	N.C.	No Connect.

CN2 and CN3: Refer to Figure 1

PHYSICAL DIMENSIONS

LXM1640-01

All dimensions are in inches (mm)

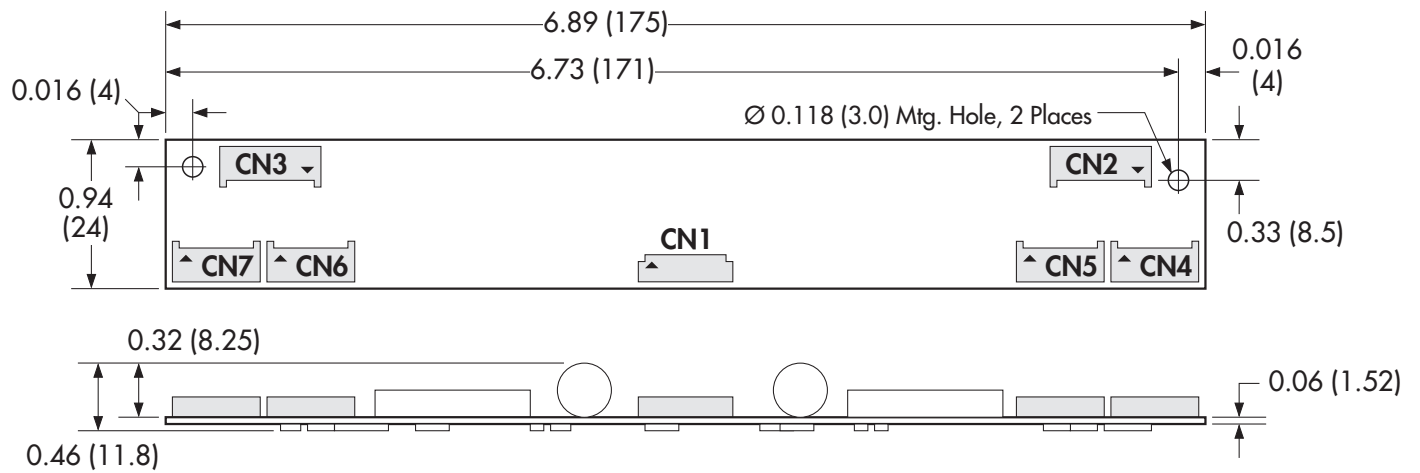

LXM1640-01

DIRECT DRIVE QUAD LAMP CCFL INVERTER MODULE

PRELIMINARY DATA SHEET

CONNECTOR SCHEMATIC

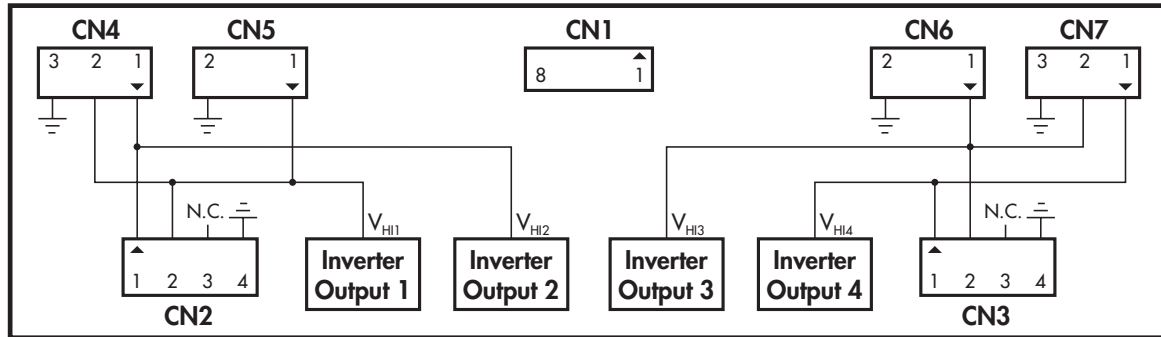

FIGURE 1 — LXM1640-01 Connector Schematic

Connectors:

CN1 = MOLEX 53261-0890

CN2, CN3 = JST SM04(4.0)B-BHS-1-TB

CN4, CN7 = JST SM03(4.0)B-BHS-1-TB

CN5, CN6 = JST SM02(8.0)B-BHS-1-TB

Mates With:

Pins: 50079-8100*, Housing: 51021-0800

* Loose (-8000, Chain) Recommended #26 AWG wiring

JST BHR-04VS-1

JST BHR-03VS-1

JST BHR-03VS-1

Connection Rules

1. Always install four (4) lamps. Operating with out all lamps may overdrive lamp current at maximum brightness settings.
2. Verify lamp wiring before connecting lamps to the inverter module. Connecting more than one lamp to one of the four inverter output circuits will result in reduced brightness. The LXM1640-01 module connectors are wired per industry standard. The lamp **hot** wires (high voltage wires) are always on pin 1 or 2, and the **cold** wire (low voltage wire) is always on pin 3 or 4.

FAILSAFE FEATURE FOR MULTIPLE LAMP OPERATIONS

Our multi-output inverters are designed to keep your application operating at near normal brightness in the event that a lamp fails. This allows the display to remain "on-line" until lamp replacement is convenient.

Linfinitiy "pairs" the lamps so that if one lamp in the pair breaks, most of its current is added to the good lamp. CCFLs will respond with more brightness for a period of time. Operating time in this mode will be a function of the lamps age but should be typically in the order of hundreds of hours.

This operating characteristic can provide adequate display performance for a limited, but useful period of time. Shortening of the lamp life in this mode is typically not a concern as it is recommended that all lamps in a display be replaced at the same time.

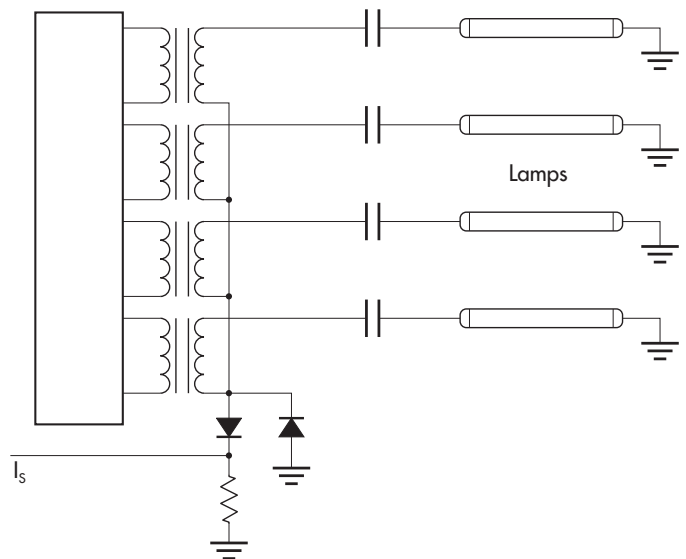

FIGURE 2 — Quad Output Stage

DIRECT DRIVE QUAD LAMP CCFL INVERTER MODULE

PRELIMINARY DATA SHEET

DIRECT DRIVE OUTPUT ARCHITECTURE

Direct Drive architecture includes two load feedback control loops to provide uncompromised CCFL ignition and operation characteristics.

Lamp current is regulated in the CCFL return lead (I_{SNS} loop) to insure constant light output with changing lamp parameters and power supply voltage. This also allows accurate and repeatable brightness control. Dimming ratio with the LX1640 analog dimming inverters is typically 6:1 when driving quad LCD lamp panels.

If no current flows in the CCFL return path because of an unstruck or failed lamp, the inverter applies full strike voltage potential. The output voltage feedback loop (V_{SNS}) takes control and regulates output voltage to $1650V_{RMS}$. This insures lamps will ignite under worst case temperature and aging conditions.

Because output voltage is actively regulated, it will never exceed component and panel insulation ratings. This prevents destructive corona discharge to insure long term reliability of the system.

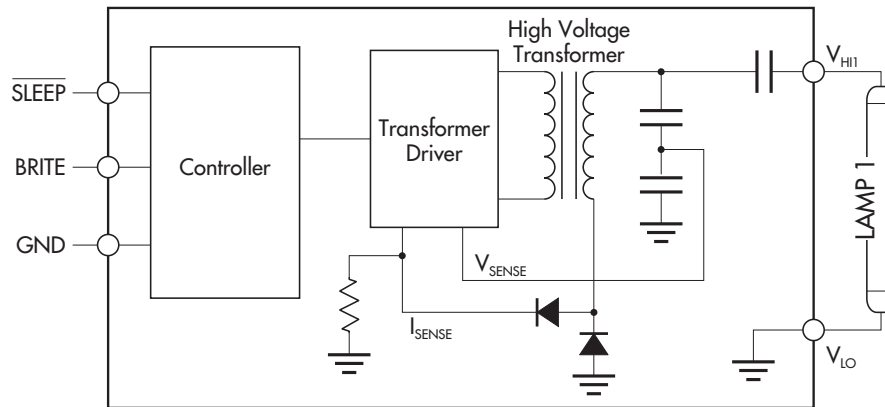

FIGURE 3 — LXM1640 Block Diagram
(Only one lamp shown)

TYPICAL APPLICATIONS

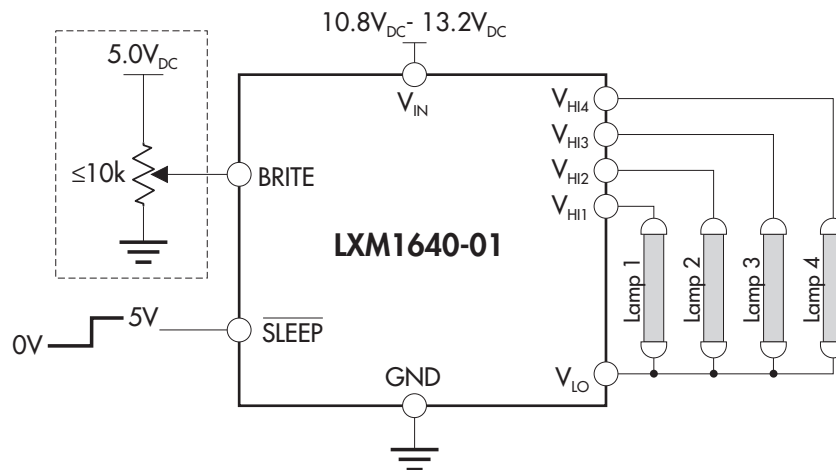

FIGURE 4 — Potentiometer Brightness Control

PRELIMINARY DATA - Information contained in this document is pre-production data, and is proprietary to Linfinity. It may not be modified in any way without the express written consent of Linfinity. Product referred to herein is offered in sample form only, and Linfinity reserves the right to change or discontinue this proposed product at any time.