

**MLL5221
thru
MLL5281**

DESCRIPTION/FEATURES

- LEADLESS PACKAGE FOR SURFACE MOUNT TECHNOLOGY
- IDEAL FOR HIGH DENSITY MOUNTING
- VOLTAGE RANGE—2.4 TO 200 VOLTS
- HERMETICALLY SEALED, DOUBLE-SLUG GLASS CONSTRUCTION
- METALLURGICALLY BONDED CONSTRUCTION AVAILABLE AS DASH ONE.

MAXIMUM RATINGS

500 mW DC Power Rating (See Power Derating Curve)
-65°C to +200°C Operating and Storage Junction Temperature
Power Derating 3.33 mW/°C above 50°C

APPLICATION

This surface mountable zener diode series is similar to the 1N5221 thru 1N5281 registration in the DO-35 equivalent package except that it meets the new JEDEC surface mount outline DO-213AA. It is an ideal selection for applications of high density and low parasitic requirements. Due to its glass hermetic qualities, it may also be considered for high reliability applications when required by a source control drawing (SCD).

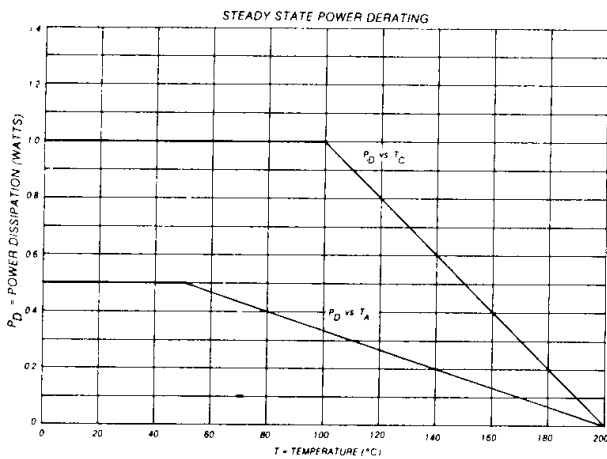

**LEADLESS GLASS
ZENER DIODES**

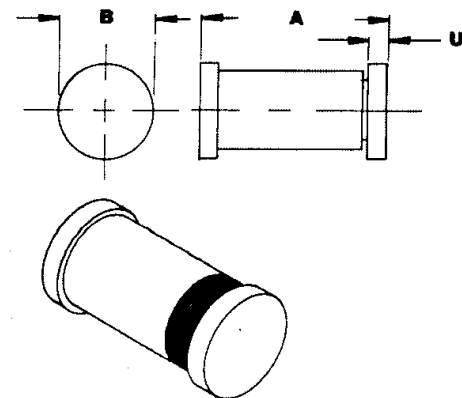

DIM	MILLIMETERS		INCHES	
	MIN	MAX	MIN	MAX
A	3.30	3.70	0.130	0.146
B	1.65	1.75	0.065	0.067
U	41	55	0.016	0.022

DO-213AA

**MECHANICAL
CHARACTERISTICS**

CASE: Hermetically sealed glass with solder contact tabs at each end.

FINISH: All external surfaces are corrosion resistant, readily solderable.

POLARITY: Banded end is cathode.

THERMAL RESISTANCE: 100°C/Watt typical junction to contact (case) tabs.

MOUNTING POSITION: Any.

MLL5221 thru MLL 5281

ELECTRICAL CHARACTERISTICS

($T_A = 25^\circ\text{C}$ unless otherwise noted. Based on dc measurements at thermal equilibrium; case temperature maintained at $30 \pm 2^\circ\text{C}$. $V_F = 1.1\text{V}$ max @ $I_F = 200\text{ mA}$ for all types.)

Type No. (Note 1)	Nominal Zener Voltage V_Z @ I_{ZT} (Note 2)	Test Current I_{ZT} mA	Max Zener Impedance A and B Suffix only		Max Reverse Leakage Current				Max Zener Voltage Temperature Coeff. (A and B Suffix only) α_{VZ} (%/°C) (Note 3)
			Z_{Z1} @ I_{ZT} Ohms	Z_{ZK} @ $I_{ZK} = 0.25\text{ mA}$ Ohms	A and B Suffix only		Non-Suffix		
					I_R μA	@ V _R Volts	I_R @ V_R Used for Suffix A μA		
MLL5221	2.4	20	30	1200	100	0.95	1.0	200	-0.085
MLL5222	2.5	20	30	1250	100	0.95	1.0	200	-0.085
MLL5223	2.7	20	30	1300	75	0.95	1.0	150	-0.080
MLL5224	2.8	20	30	1400	75	0.95	1.0	150	-0.080
MLL5225	3.0	20	29	1600	50	0.95	1.0	100	-0.075
MLL5226	3.3	20	28	1600	25	0.95	1.0	100	-0.070
MLL5227	3.6	20	24	1700	15	0.95	1.0	100	-0.065
MLL5228	3.9	20	23	1900	10	0.95	1.0	75	-0.060
MLL5229	4.1	20	22	2000	5.0	0.95	1.0	50	± 0.055
MLL5230	4.7	20	19	1900	5.0	1.9	2.0	50	± 0.030
MLL5231	5.1	20	17	1600	5.0	1.9	2.0	50	± 0.038
MLL5232	5.6	20	15	1600	5.0	3.3	3.5	50	± 0.038
MLL5233	6.0	20	7.0	1600	5.0	3.8	4.0	50	± 0.045
MLL5234	6.2	20	7.0	1600	5.0	3.8	4.0	50	± 0.045
MLL5235	6.8	20	5.0	750	3.0	4.8	5.0	30	± 0.050
MLL5236	7.5	20	6.0	500	3.0	5.7	6.0	30	± 0.058
MLL5237	8.2	20	6.0	500	3.0	6.2	6.5	30	± 0.062
MLL5238	8.7	20	8.0	600	3.0	6.2	6.5	30	± 0.065
MLL5239	9.1	20	10	600	3.0	6.7	7.0	30	± 0.068
MLL5240	10	20	17	600	3.0	7.6	8.0	30	± 0.075
MLL5241	11	20	22	600	2.0	8.0	8.4	30	± 0.076
MLL5242	12	20	30	600	1.0	8.7	9.1	10	± 0.077
MLL5243	13	9.5	13	600	0.5	9.4	9.9	10	± 0.079
MLL5244	14	9.0	15	600	0.1	9.5	10	10	± 0.082
MLL5245	15	6.5	18	600	0.1	10.5	11	10	± 0.082
MLL5246	16	7.8	17	600	0.1	11.4	12	10	± 0.083
MLL5247	17	7.4	19	600	0.1	12.4	13	10	± 0.084
MLL5248	18	7.0	21	600	0.1	13.3	14	10	± 0.085
MLL5249	19	6.6	23	600	0.1	13.3	14	10	± 0.086
MLL5250	20	6.2	25	600	0.1	14.3	15	10	± 0.086
MLL5251	22	5.6	29	600	0.1	16.2	17	10	± 0.087
MLL5252	24	5.2	33	600	0.1	17.1	18	10	± 0.088
MLL5253	25	5.0	35	600	0.1	18.1	19	10	± 0.089
MLL5254	27	4.6	41	600	0.1	20	21	10	± 0.090
MLL5255	28	4.5	44	600	0.1	20	21	10	± 0.091
MLL5256	30	4.2	49	600	0.1	22	23	10	± 0.091
MLL5257	33	3.8	58	700	0.1	24	25	10	± 0.092
MLL5258	36	3.4	70	700	0.1	26	27	10	± 0.093
MLL5259	39	3.2	83	800	0.1	29	30	10	± 0.094
MLL5260	43	3.0	93	900	0.1	31	33	10	± 0.095
MLL5261	47	2.7	105	1000	0.1	34	36	10	± 0.095
MLL5262	51	2.5	125	1100	0.1	37	39	10	± 0.096
MLL5263	56	2.2	150	1300	0.1	41	43	10	± 0.096
MLL5264	60	2.1	170	1400	0.1	44	46	10	± 0.097
MLL5265	62	2.0	185	1400	0.1	45	47	10	± 0.097
MLL5266	68	1.8	230	1600	0.1	49	52	10	± 0.097
MLL5267	75	1.7	270	1700	0.1	53	56	10	± 0.098
MLL5268	82	1.5	330	2000	0.1	59	62	10	± 0.098
MLL5269	87	1.4	370	2200	0.1	65	68	10	± 0.099
MLL5270	91	1.4	400	2300	0.1	66	69	10	± 0.099
MLL5271	100	1.3	500	2600	0.1	72	76	10	± 0.110
MLL5272	110	1.1	750	3000	0.1	80	84	10	± 0.110
MLL5273	120	1.0	900	4000	0.1	86	91	10	± 0.110
MLL5274	130	0.95	1100	4500	0.1	94	99	10	± 0.110
MLL5275	140	0.90	1300	4500	0.1	101	106	10	± 0.110
MLL5276	150	0.85	1500	5000	0.1	108	114	10	± 0.110
MLL5277	160	0.80	1700	5500	0.1	116	122	10	± 0.110
MLL5278	170	0.74	1900	5500	0.1	123	129	10	± 0.110
MLL5279	180	0.68	2200	6000	0.1	130	137	10	± 0.110
MLL5280	190	0.66	2400	6500	0.1	137	144	10	± 0.110
MLL5281	200	0.65	2500	7000	0.1	144	152	10	± 0.110

CAPACITANCE vs. V_Z CURVE

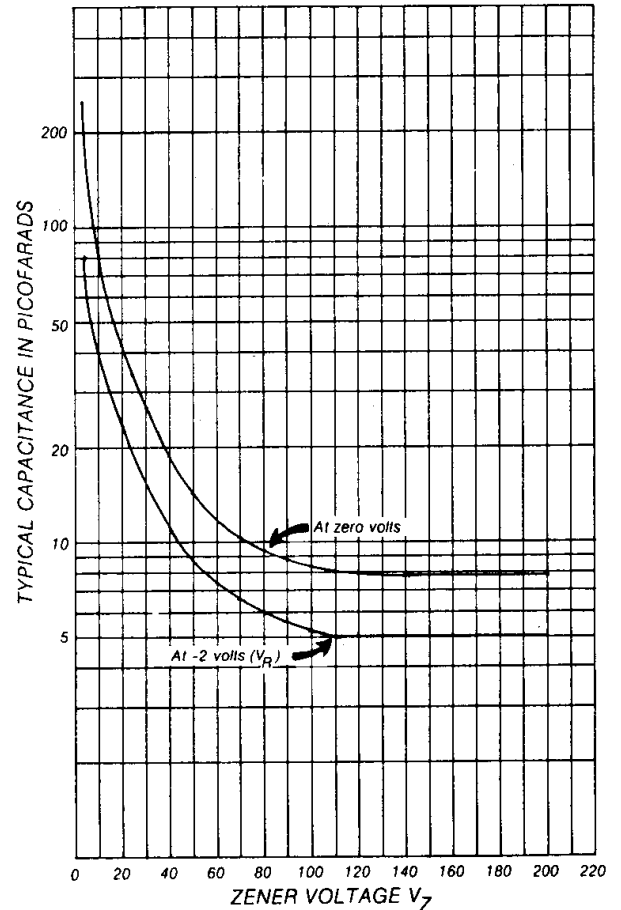

NOTE 1: Table as shown lists type numbers, which indicate a tolerance of $\pm 20\%$ with guaranteed limits on only V_Z , I_R , and V_F . Devices with guaranteed limits on all six parameters are indicated by suffix "A" for $\pm 10\%$, "B" for $\pm 5\%$, "C" for $\pm 2\%$, and "D" for $\pm 1\%$ tolerance.

NOTE 2: The electrical characteristics are measured after allowing the device to stabilize for 20 seconds.

NOTE 3: Temperature coefficient (α_{VZ}). Test conditions for temperature coefficient are as follows:

- $I_{ZT} = 7.5\text{ mA}$, $T_1 = 25^\circ\text{C}$,
 $T_2 = 125^\circ\text{C}$ (MLL5221A, B thru MLL5242A, B.)
- $I_{ZT} = \text{Rated } I_{ZT}$, $T_1 = 25^\circ\text{C}$,
 $T_2 = 125^\circ\text{C}$ (MLL5243A, B thru MLL5281A, B.)

Device to be temperature stabilized with current applied prior to reading breakdown voltage at the specified ambient temperature.