

**MLL957B,-1
 thru
 MLL992B,-1**
±1% and ±2% Versions
“C” and “D” Available

**LEADLESS GLASS
 ZENER DIODE
 SURFACE MOUNT**

Features

- Leadless Package For Surface Mount Technology
- Ideal For High Density Mounting
- Voltage Range 6.8 To 200 Volts
- Hermetically Sealed, Double Slug Glass Construction
- Metallurgically Bonded Construction Available as Dash One.
- Available in JAN, JTX, JTXV-1 to Mil-PRF-19500/117 (UR-1 Suffix)

Maximum Ratings

500 mW DC Power Dissipation (See Power Derating Curve In Figure 1)
 -55°C to +175°C Operating and Storage Junction Temperature

Application

This surface mountable zener diode series is similar to the 1N957B thru 1N992B in the DO-35 equivalent package except that it meets the new JEDEC surface mount outline DO-213AA. It is an ideal selection for applications of high density and low parasitic requirements. Due to its glass hermetic qualities, it may also be considered for high reliability applications.

Electrical Characteristics (see next page)

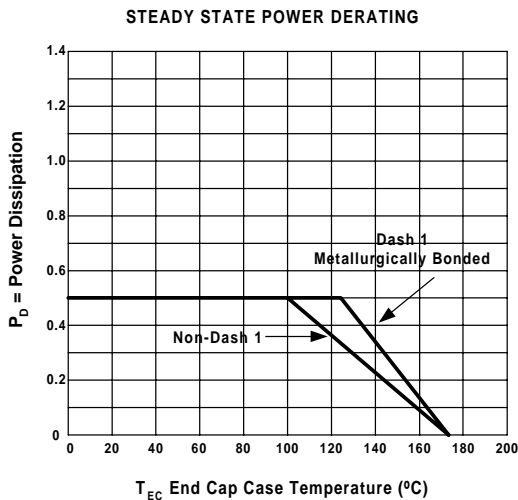
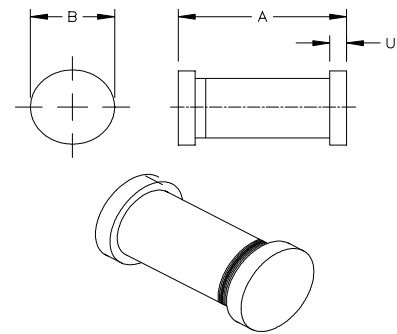

FIGURE 1

Package Dimensions In Inches



DIM	MILLIMETERS		INCHES	
	MIN	MAX	MIN	MAX
A	3.30	3.70	.130	.146
B	1.60	1.70	.063	.067
U	0.41	0.55	.016	.022

DO-213AA

Mechanical Characteristics

Case: Hermetically sealed glass with solder contact tabs at each end.

Finish: All external surfaces are corrosion resistant, readily solderable.

Polarity: Banded end is cathode.

Thermal Resistance: 100°C/Watt Maximum junction to end caps for "-1" construction and 150°C/W maximum junction to end caps for commercial.

Mounting Position: Any

Weight: 0.04 gm



**MLL957B,-1
thru
MLL992B,-1
±1% and ±2% Versions
“C” and “D” Available**

Electrical Characteristics @ 25°C

MICROSEMI PART NUMBER	NOMINAL ZENER VOLTAGE $V_Z @ I_{ZT}$ (NOTE 1)	ZENER TEST CURRENT I_{ZT}	MAX ZENER IMPEDANCE (Note 3)			MAX. DC ZENER CURRENT I_{ZM} (NOTE 4)	MAX. SURGE CURRENT (RECURRENT) (NOTE 4) I_Z (SURGE)	MAX. REVERSE LEAKAGE CURRENT		MAX.TEMP COEFFICIENT α_{VZ}
			$Z_{ZT} @ I_{ZT}$	$Z_{ZK} @ I_{ZK}$				I_R	V_R	
**	VOLTS	mA	OHMS	OHMS	mA	mA	mA	μA	VOLTS	%/°C
MLL957B	6.8	18.5	4.5	700	1.0	55	300	150	5.2	+0.050
MLL958B	7.5	16.5	5.5	700	.5	50	275	75	5.7	+0.058
MLL959B	8.2	15.0	6.5	700	.5	45	250	50	6.2	+0.065
MLL960B	9.1	14.0	7.5	700	.5	41	225	25	6.9	+0.068
MLL961B	10	12.5	8.5	700	.25	38	200	10	7.6	+0.075
MLL962B	11	11.5	9.5	700	.25	32	175	5	8.4	+0.076
MLL963B	12	10.5	11.5	700	.25	31	160	5	9.1	+0.077
MLL964B	13	9.5	13.0	700	.25	28	150	5	9.9	+0.079
MLL965B	15	8.5	16	700	.25	25	130	5	11.4	+0.082
MLL966B	16	7.8	17	700	.25	24	120	5	12.2	+0.083
MLL967B	18	7.0	21	750	.25	20	110	5	13.7	+0.085
MLL968B	20	6.2	25	750	.25	18	100	5	15.2	+0.086
MLL969B	22	5.6	29	750	.25	16	90	5	16.7	+0.087
MLL970B	24	5.2	33	750	.25	15	80	5	18.2	+0.088
MLL971B	27	4.6	41	750	.25	13	70	5	20.6	+0.090
MLL972B	30	4.2	49	1000	.25	12	65	5	22.8	+0.091
MLL973B	33	3.8	58	1000	.25	11	60	5	25.1	+0.092
MLL974B	36	3.4	70	1000	.25	10	55	5	27.4	+0.093
MLL975B	39	3.2	40	1000	.25	9.5	46	5	29.7	+0.094
MLL976B	43	3.0	93	1500	.25	8.8	44	5	32.7	+0.095
MLL977B	47	2.7	105	1500	.25	7.9	40	5	35.8	+0.095
MLL978B	51	2.5	125	1500	.25	7.4	37	5	38.8	+0.096
MLL979B	56	2.2	150	2000	.25	6.8	35	5	42.6	+0.096
MLL980B	62	2.0	185	2000	.25	6.0	30	5	47.1	+0.097
MLL981B	68	1.8	230	2000	.25	5.5	28	5	51.7	+0.097
MLL982B	75	1.7	270	2000	.25	5.0	26	5	56.0	+0.098
MLL983B	82	1.5	330	3000	.25	4.6	23	5	62.2	+0.098
MLL984B	91	1.4	400	3000	.25	4.1	21	5	69.2	+0.099
MLL985B	100	1.3	500	3000	.25	3.7	18	5	76.0	+0.110
MLL986B	110	1.1	750	4000	.25	3.3	16	5	83.6	+0.110
MLL987B	120	1.0	900	4500	.25	3.1	15	5	91.2	+0.110
MLL988B	130	0.95	1100	5000	.25	2.7	13	5	98.8	+0.110
MLL989B	150	0.85	1500	6000	.25	2.4	12	5	114.0	+0.110
MLL990B	160	0.80	1700	6500	.25	2.2	11	5	121.6	+0.110
MLL991B	180	0.68	2200	7100	.25	2.0	10	5	136.8	+0.110
MLL992B	200	0.65	2500	8000	.25	1.8	9	5	152.0	+0.110

Note 1 Voltage measurements to be performed 20 seconds after application of dc test current.

Note 2 Zener impedance derived by superimposing on I_{ZT} at 60 Hz rms ac current equal to 10% I_{ZT} .

Note 3 Allowance has been made for the increase in V_Z due to Z_Z and for the increase in junction temperature as the unit approaches thermal equilibrium at the power dissipation at 500 mW.

** Ordering Information:

- 1) Commercial: MLL957B thru MLL992B or MLL957B-1 thru MLL992B-1
- 2) Military: JAN, JANTX, or JANTXV 1N962BUR-1 thru 1N992BUR-1
- 3) Tight tolerance "C" suffix = ±2%, "D" suffix = ±1%
- 4) Surge is square wave or equivalent ½ sine wave pulse of 1/120 second duration.

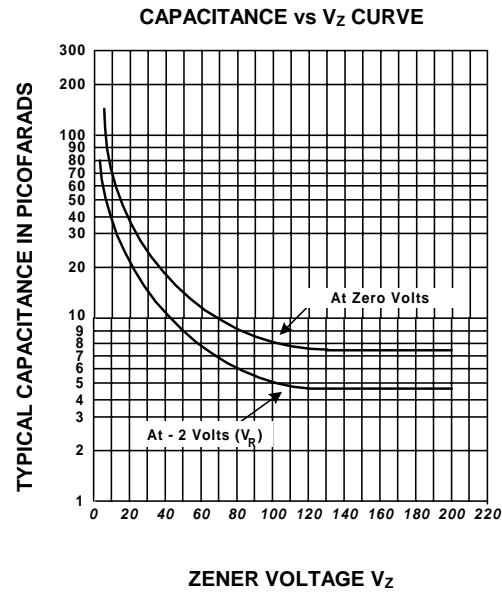

FIGURE 2

**CAPACITANCE VS ZENER VOLTAGE
(TYPICAL)**