

MM054

Features

- High current capability, easy to parallel to further boost up performance
- Compact and rugged construction offering weight and space savings
- Available with PC board solderable pins (see mechanical outline below) or threaded terminals (add "T" suffix to part number, see option below)
- HPM (Hermetic Power Module)
- Isolation voltage capability (in reference to the base) in excess of 3kV
- Very low thermal resistance
- Thermally matched construction provides excellent temperature and power cycling capability
- Additional voltage ratings or terminations available upon request
- MIL-PRF-19500 screening available upon request

DISCHARGE: 100 A
CHARGE: 20 A

BATTERY BYPASS CIRCUIT

Maximum Ratings per leg @ 25°C (unless otherwise specified)

PART NUMBER	SYMBOL	MAX.	UNIT
Discharge Current	ID	100	Amps
Charge Current	IC	20	Amps
Non-Repetitive Peak Surge Current (discharge)	IDS _M	500	Amps
Non-Repetitive Peak Surge Current (charge)	ICS _M	200	Amps
Operating and Storage Junction Temperature Range	T _j T _{stg}	-55 to +175	°C
Thermal resistance, junction to base, discharge	R _{θjbD}	0.7 (typ. 0.5)	°C/W
Thermal resistance, junction to base, charge	R _{θjbC}	0.9 (typ. 0.75)	°C/W

Mechanical Outline

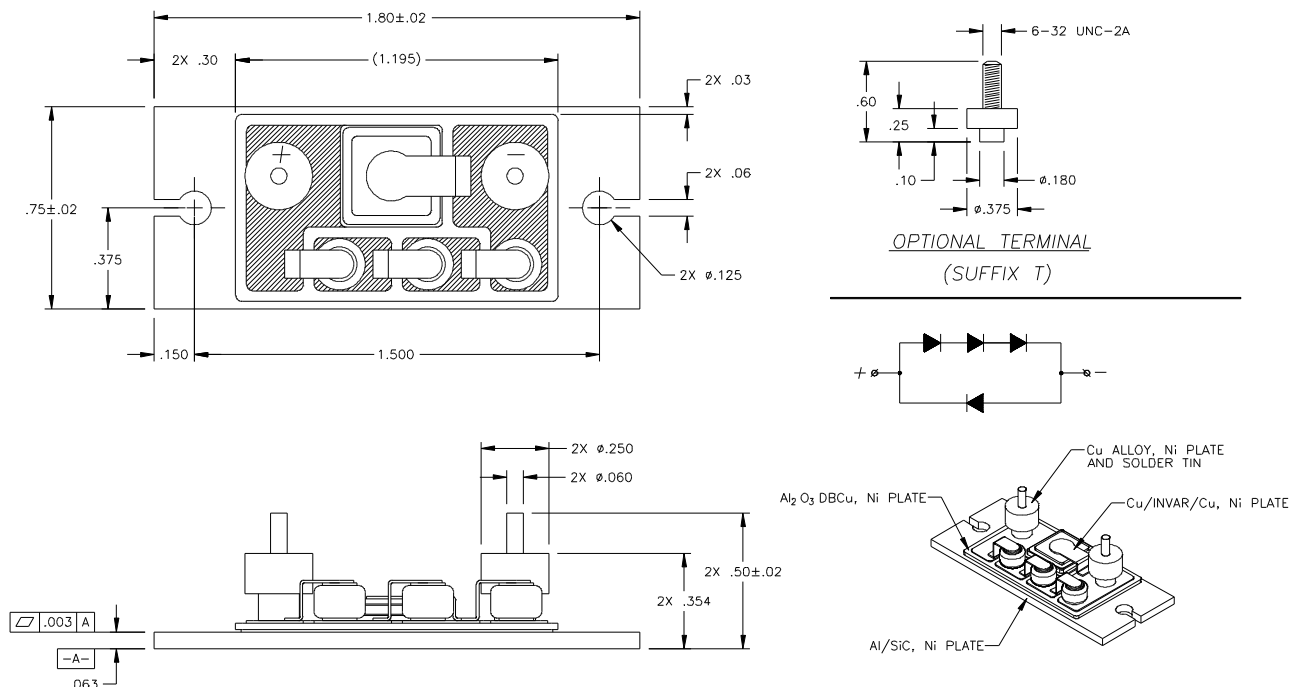

Electrical Parameters, DISCHARGE circuit @ 25°C (unless otherwise specified)

DESCRIPTION	SYMBOL	CONDITIONS	MIN	TYP.	MAX	UNIT
Forward Voltage, note 1	VD1	IF= 10 A,		350	340	mV
Forward Voltage, note 1	VD2	IF= 20 A,		400	470	mV
Forward Voltage, note 1	VD3	IF= 40 A,		490	600	mV
Forward Voltage, note 1	VD4	IF= 80 A,		530	800	mV
Forward Voltage, note 1	VD5	IF= 100 A,		750	-	mV
Forward Voltage, note 1	VD6	IF= 20 A, TA= -55°C		490	590	mV
Forward Voltage, note 1	VD7	IF= 20 A, TA= 125°C		320	-	mV

note: see 1N6790 data sheet for full electrical characteristics of the discharge schottky diode

Electrical Parameters, CHARGE circuit @ 25°C (unless otherwise specified)

DESCRIPTION	SYMBOL	CONDITIONS	MIN	TYP.	MAX	UNIT
Forward Voltage, note 1	VC1	IF= 50 mA	2	2.1	-	V
Forward Voltage, note 1	VC2	IF= 100 mA	-	2.2	-	V
Forward Voltage, note 1	VC3	IF= 5 A,		2.6	2.7	V
Forward Voltage, note 1	VC4	IF= 10 A,		2.7	3.0	V
Forward Voltage, note 1	VC5	IF= 20 A,		2.85	3.3	V
Forward Voltage, note 1	VC4	IF= 10 A, TA= 125°C		2.35	2.7	V

Notes

(1) Pulse test, t ≤ 300 ns, duty cycle ≤ 2%