

25 Amp Schottky Rectifier SBR2530 – SBR2545

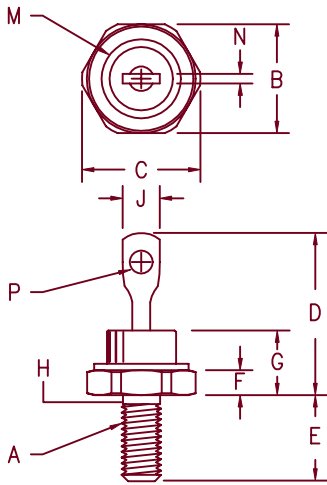

- Notes:
1. 10–32 UNF3A threads
 2. Full threads within 2 1/2 threads
 3. Standard Polarity:
Stud is Cathode
Reverse Polarity: Stud is Anode

Dim.	Inches		Millimeter		Notes
	Minimum	Maximum	Minimum	Maximum	
A	---	---	---	---	1
B	.424	.437	10.77	11.10	
C	---	.505	---	12.82	
D	.600	.800	15.24	20.32	
E	.422	.453	10.72	11.50	
F	.075	.175	1.91	4.44	
G	---	.405	---	10.29	
H	.163	.189	4.15	4.80	2
J	---	.310	---	7.87	
M	---	.350	---	8.89	Dia.
N	.020	.065	.510	1.65	
P	.060	.100	1.53	2.54	Dia.

D0203AA (D04)

Microsemi Catalog Number	Working Peak Reverse Voltage	Repetitive Peak Reverse Voltage
SBR2530*	30V	30V
SBR2535*	35V	35V
SBR2540*	40V	40V
SBR2545*	45V	45V

*Add the Suffix R for Reverse Polarity

- Schottky Barrier Rectifier
- Guard Ring Protection
- Low Forward Voltage
- VRRM – 30 to 45V
- 25 Amperes
- Reverse Energy Tested

Electrical Characteristics

Average forward current	$I_{F(AV)}$ 25 Amps	$T_C = 105^\circ\text{C}$, Square wave, $R_{\theta JC} = 1.6^\circ\text{C/W}$ 8.3 ms, half sine $T_J = 150^\circ\text{C}$ $f = 1 \text{ KHz}$, 25°C , $1 \mu\text{sec}$ Square wave
Maximum surge current	I_{FSM} 600 Amps	
Max repetitive peak reverse current	$I_{R(OV)}$ 2 Amps	$I_{FM} = 25\text{A}$: $T_J = 150^\circ\text{C}^*$ $I_{FM} = 25\text{A}$: $T_J = 25^\circ\text{C}^*$ V_{RRM} , $T_J = 125^\circ\text{C}^*$ V_{RRM} , $T_J = 25^\circ\text{C}$ $V_R = 5.0\text{V}$, $T_J = 25^\circ\text{C}$
Max peak forward voltage	V_{FM} .53 Volts	
Max peak forward voltage	V_{FM} .58 Volts	
Max peak reverse current	I_{RM} 250 mA	
Max peak reverse current	I_{RM} 2 mA	
Typical junction capacitance	C_J 1200 pF	

*Pulse test: Pulse width 300 μsec , Duty cycle 2%

Thermal and Mechanical Characteristics

Storage temp range	T_{STG}	-55°C to 175°C
Operating junction temp range	T_J	-55°C to 150°C
Max thermal resistance	$R_{\theta JC}$	1.6°C/W Junction to case
Typical thermal resistance (greased)	$R_{\theta CS}$	0.5°C/W Case to sink
Mounting torque		12–15 inch pounds
Weight		0.2 ounces (6.0 grams) typical

SBR2530 — SBR2545

Figure 1
Typical Forward Characteristics

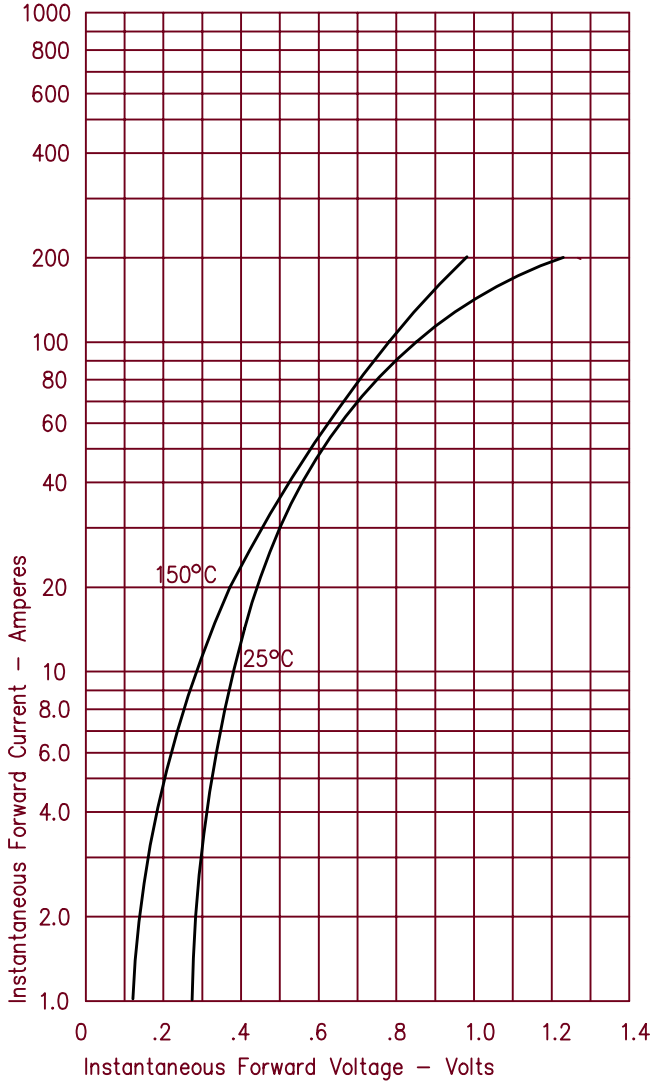

Figure 3
Typical Junction Capacitance

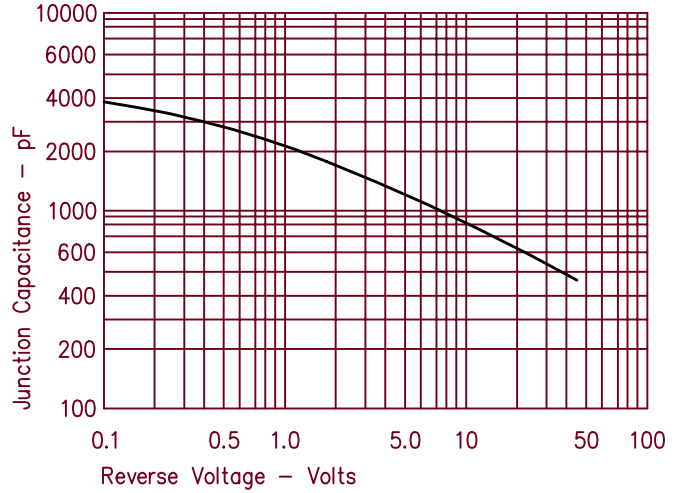

Figure 4
Forward Current Derating

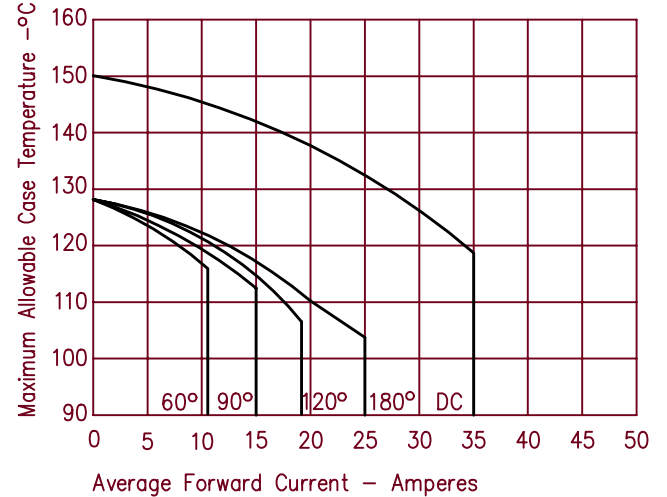

Figure 2
Typical Reverse Characteristics

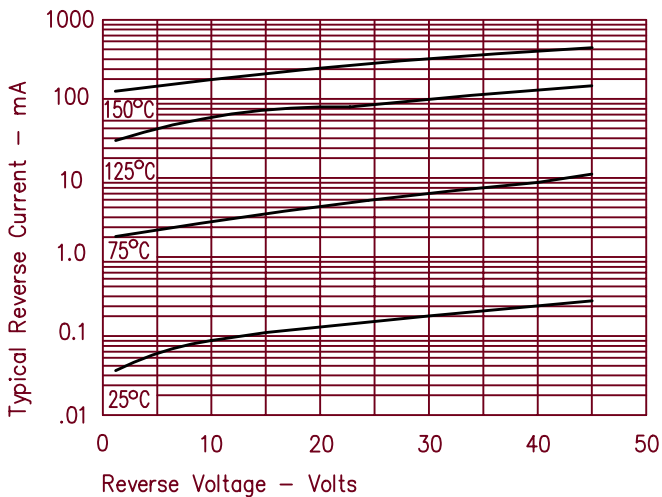

Figure 5
Maximum Forward Power Dissipation

