

60 Amp Schottky Rectifier

SBR6035PF — SBR6045PF

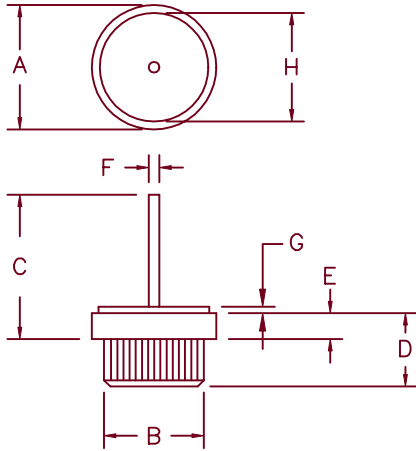

Dim.	Inches		Millimeter		Notes
	Minimum	Maximum	Minimum	Maximum	
A	.590	.630	15.0	16.0	Dia.
B	.499	.510	12.6	13.0	Dia.
C	—	.600	—	15.2	
D	.350	.370	8.90	9.40	
E	.090	.130	2.28	3.30	
F	.097	.103	2.46	2.62	Dia.
G	.030	.035	.762	.900	
H	.500	.510	12.7	13.0	Dia.

Microsemi Catalog Number	Working Peak Reverse Voltage	Repetitive Peak Reverse Voltage
SBR6035PF*	35V	35V
SBR6040PF*	40V	40V
SBR6045PF*	45V	45V

*Add the Suffix R for Reverse Polarity

- Schottky Barrier Rectifier
- Guard Ring Protected
- 150°C Junction Temperature
- VRRM — 35 to 45 Volts
- Reverse Energy Tested

Electrical Characteristics

Average forward current	$I_F(AV)$ 60 Amps	$T_C = 89^\circ\text{C}$, Square wave, $R_{\theta JC} = 1.0^\circ\text{C/W}$
Maximum surge current	I_{FSM} 800 Amps	8.3 ms, half sine, $T_J = 150^\circ\text{C}$
Max repetitive peak reverse current	$I_R(OV)$ 2 Amps	$f = 1 \text{ KHz}$, 25°C , 1 μsec Square wave
Max peak forward voltage	V_{FM} .58 Volts	$I_{FM} = 60\text{A}$: $T_J = 150^\circ\text{C}^*$
Max peak forward voltage	V_{FM} .60 Volts	$I_{FM} = 60\text{A}$: $T_J = 25^\circ\text{C}^*$
Max peak reverse current	I_{RM} 600 mA	V_{RRM} , $T_J = 125^\circ\text{C}^*$
Max peak reverse current	I_{RM} 2 mA	V_{RRM} , $T_J = 25^\circ\text{C}$
Maximum junction capacitance	C_J 2700 pF	$V_R = 5.0\text{V}$, $T_J = 25^\circ\text{C}$

*Pulse test: Pulse width 300 μsec , Duty cycle 2%

Thermal and Mechanical Characteristics

Storage temp range	T_{STG}	-55°C to 175°C
Operating junction temp range	T_J	-55°C to 150°C
Max thermal resistance	$R_{\theta JC}$	1.0°C/W Junction to case
Weight		.32 ounces (9.2 grams) typical

SBR6035PF

— SBR6045PF

Figure 1
Typical Forward Characteristics

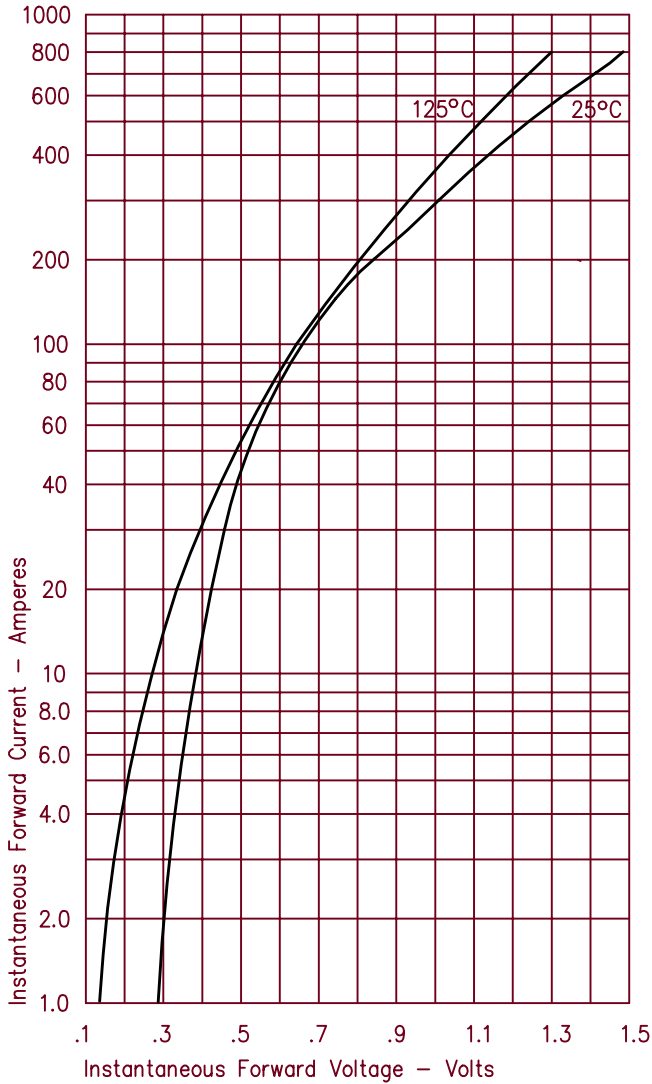

Figure 3
Typical Junction Capacitance

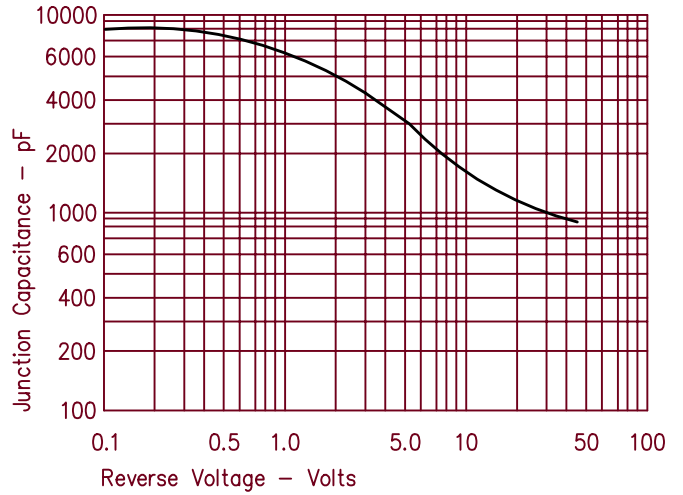

Figure 4
Forward Current Derating

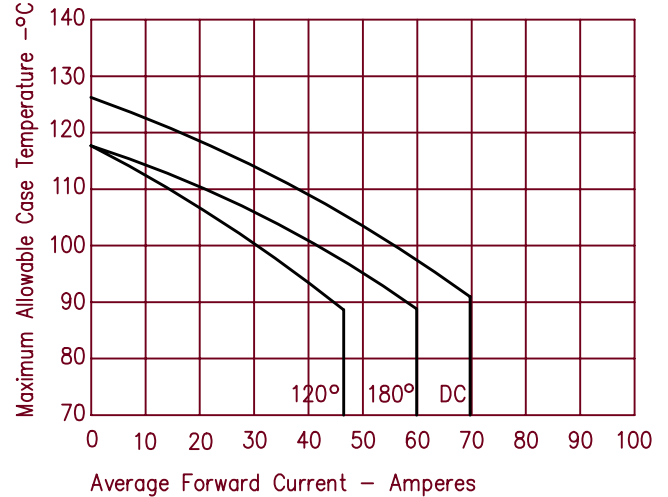

Figure 2
Typical Reverse Characteristics

