

RF & MICROWAVE TRANSISTORS
108...152MHz APPLICATIONS

- CLASS C TRANSISTOR
- FREQUENCY 136MHz
- VOLTAGE 28V
- POWER OUT 80W
- POWER GAIN 9.0dB
- COMMON EMITTER

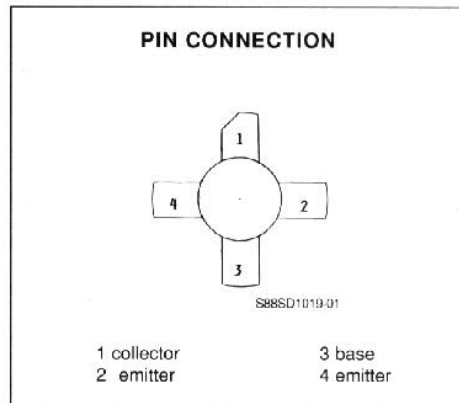
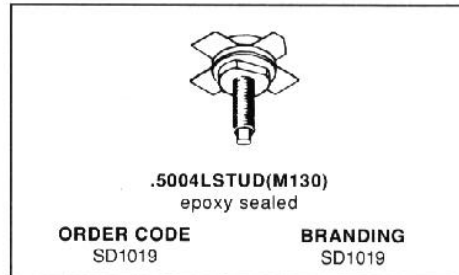

DESCRIPTION

The SD1019 is a 28 volt epitaxial silicon NPN planar transistor designed primarily for VHF communications. This device utilizes nichrome aluminium metallization to achieve infinite VSWR at rated operating conditions.

ABSOLUTE MAXIMUM RATINGS ($T_{case} = 25^{\circ}C$)

Symbol	Parameter	Value	Unit
V_{CBO}	Collector - Base Voltage	65.0	V
V_{CEO}	Collector - Emitter Voltage	35.0	V
V_{EBO}	Emitter - Base Voltage	4.0	V
I_C	Collector Current	9.0	A
P_{tot}	Total Power Dissipation	117.0	W
T_{sig}	Storage Temperature	- 65 to + 150	$^{\circ}C$
T_j	Junction Temperature	+ 200	$^{\circ}C$

THERMAL DATA

$R_{th(j-c)}$	Junction-case Thermal Resistance	1.7	$^{\circ}C/W$
---------------	----------------------------------	-----	---------------

SD1019**ELECTRICAL CHARACTERISTICS** ($T_{\text{case}} = 25^{\circ}\text{C}$)

STATIC

Symbol	Test Conditions		Value			Unit
			Min.	Typ.	Max.	
BV_{CBO}	$I_{\text{C}} = 20\text{mA}$	$I_{\text{E}} = 0$	65.0			V
BV_{CEO}	$I_{\text{C}} = 200\text{mA}$	$I_{\text{B}} = 0$	35.0			V
BV_{EBO}	$I_{\text{E}} = 10\text{mA}$	$I_{\text{C}} = 0$	4.0			V
I_{CBO}	$V_{\text{CB}} = 30.0\text{V}$	$I_{\text{E}} = 0$		1.5		mA
h_{FE}	$V_{\text{CE}} = 5.0\text{V}$	$I_{\text{C}} = 500\text{mA}$	5.0			

DYNAMIC

Symbol	Test Conditions			Value			Unit
				Min.	Typ.	Max.	
P_{O}	$f = 136\text{MHz}$	$V_{\text{CE}} = 28.0\text{V}$	80.0			W	
G_{P}	$f = 136\text{MHz}$	$V_{\text{CE}} = 28.0\text{V}$	9.0			dB	
C_{OB}	$f = 1\text{MHz}$	$V_{\text{CB}} = 30.0\text{V}$			150	pF	

APPLICATION INFORMATION (typical curves)

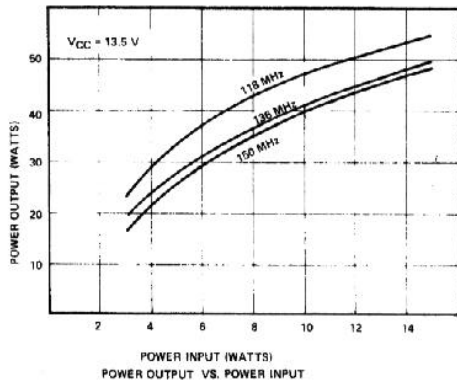

S88SD1019-02

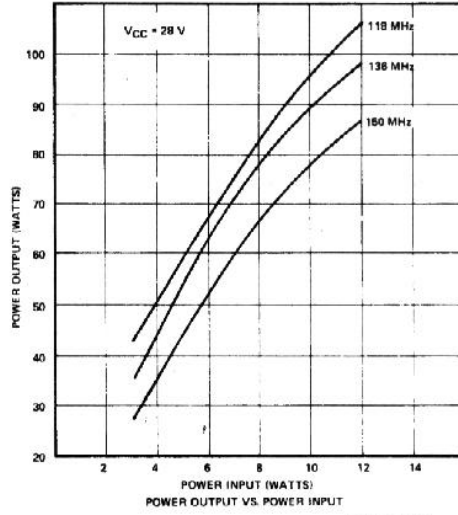

S88SD1019-03

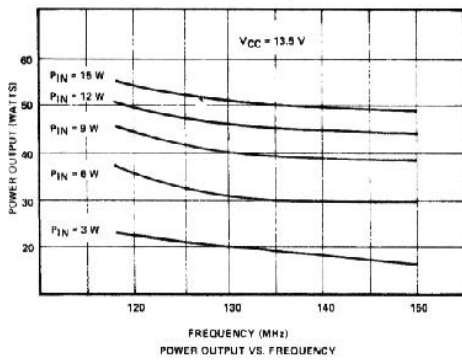

S88SD1019-04

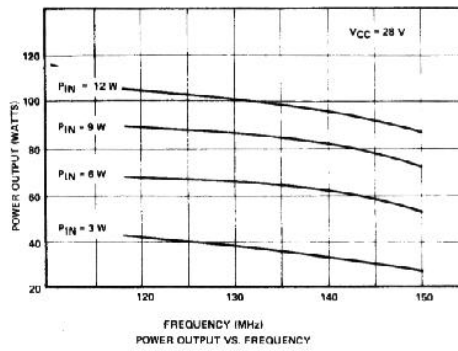

S88SD1019-05

SD1019

IMPEDANCE DATA (typical value)

$Z_S = .85 - j 0.5W$
 $Z_{CL} = 4.5 + j 1.9W$
 $F = 136MHz$

$V_{CE} = 28V$
 $P_O = 80W$

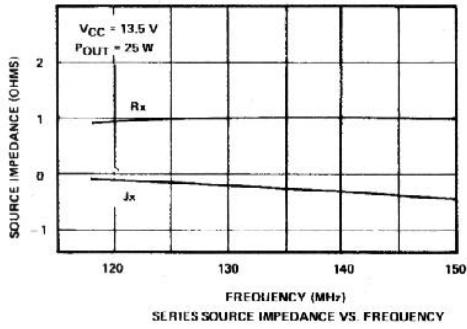

S88SD1019-06

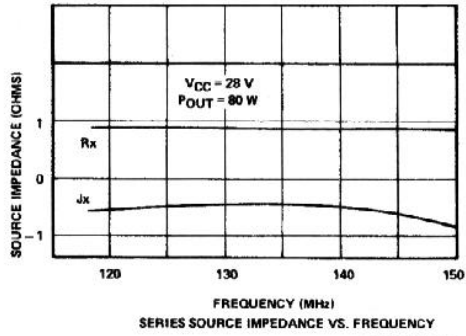

S88SD1019-07

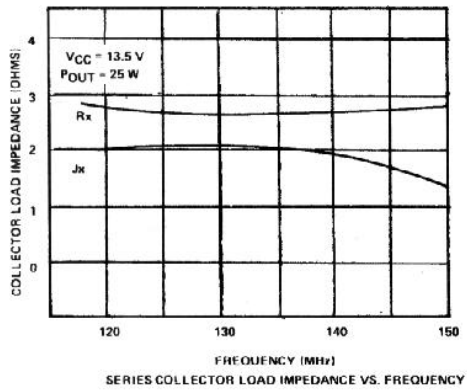

S88SD1019-09

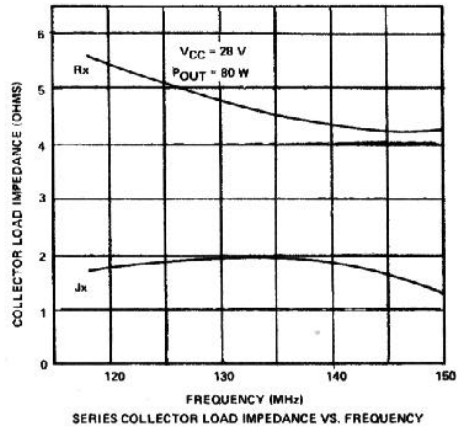

S88SD1019-10

TEST CIRCUIT

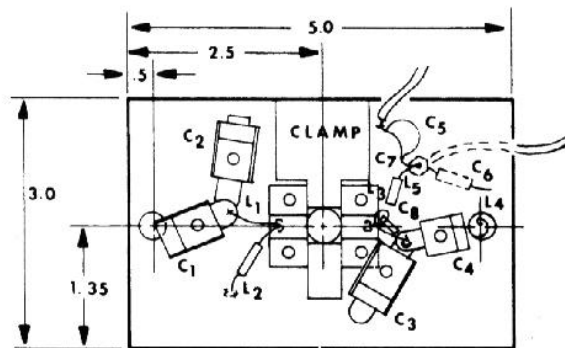
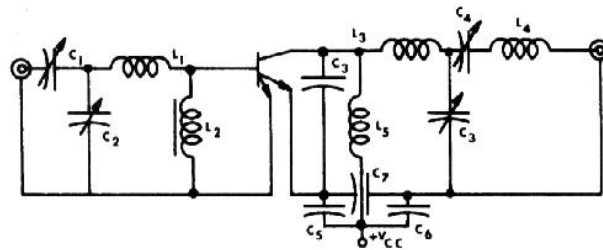

S88SD1019-10

C1 ARCO 462
 C2, C3, C4 ARCO 463
 C5 .02mF ERIE
 C6 15mF SEMCOR
 C7 AB 220pF FEEDTHRU

C8 150pF UNELCO
 L1 NO. 14AWG WIRE, .3 LONG
 L2 12mH CHOKE
 L3 1 TURN, NO 20 AWG, WIRE, 3" I.D., 25 LONG
 L4 1 TURN, NO 16 AWG, WIRE, .23" I.D., .1 LONG
 L5 .22mH DECI-DUCTOR

SD1019

PACKAGE MECHANICAL DATA

.500 4LSTUD

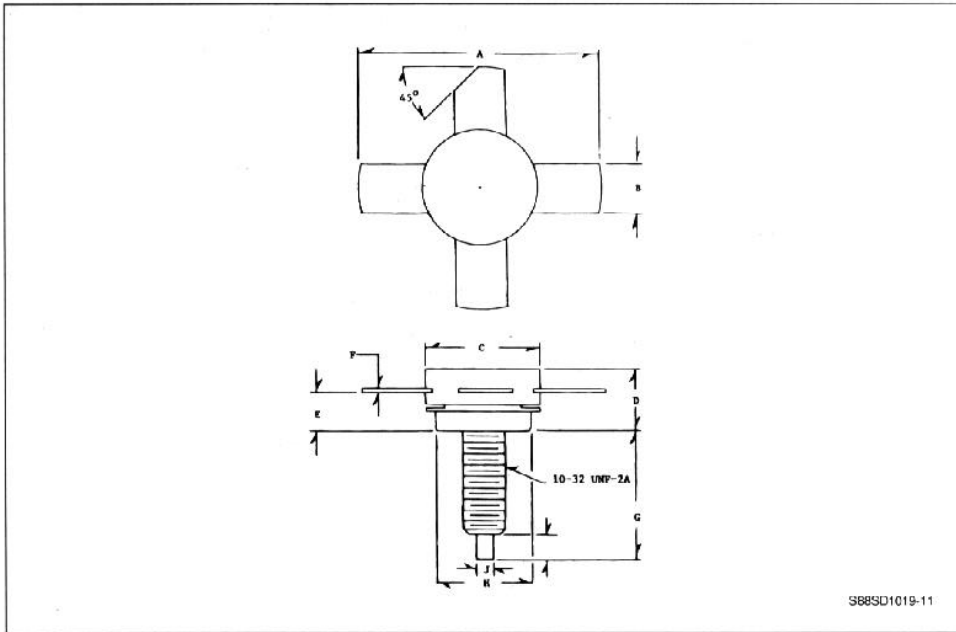

S88SD1019-11

	Minimum Inches	Maximum Inches
A		1.030
B	.220	.230
C	.490	.510
D	.250	.290
E	.160	.180
F	.004	.006
G	.550	.600
H	.415	.425
I	.100	.130
J	.065	.075