

Ultra Fast Recovery Rectifiers

UFR30, 31 & 32

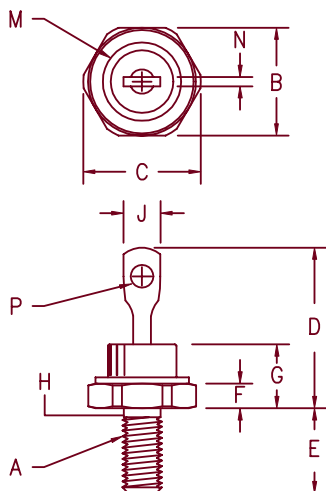

- Notes:
- 10-32 UNF3A threads
 - Full threads within 2 1/2 threads Standard Polarity: Stud is Cathode
Reverse Polarity: Stud is Anode

Dim.	Inches		Millimeter		Notes
	Minimum	Maximum	Minimum	Maximum	
A	---	---	---	---	1
B	.424	.437	10.77	11.10	
C	---	.505	---	12.82	
D	.600	.800	15.24	20.32	
E	.422	.453	10.72	11.50	
F	.075	.175	1.91	4.44	
G	---	.405	---	10.29	
H	.163	.189	4.15	4.80	2
J	.100	.310	2.54	7.87	
M	---	.350	---	8.89	Dia.
N	.020	.065	.510	1.65	
P	.070	.100	1.78	2.54	Dia.

DO203AA (D04)

- Ultra Fast Recovery Rectifier
- 175°C Junction Temperature
- V_{RRM} 100 to 800V
- High Reliability
- 30 Amps current rating
- t_{RR} 35 to 60 nsec maximum

Microsemi Catalog Number	Working Peak Reverse Voltage	Peak Reverse Voltage
UFR3010*	100V	100V
UFR3015*	150V	150V
UFR3020*	200V	200V
UFR3120*	300V	300V
UFR3130*	400V	400V
UFR3140*	500V	500V
UFR3150*	600V	600V
UFR3260*	700V	700V
UFR3270*	800V	800V
UFR3280*		

*Add Suffix R For Reverse Polarity

Electrical Characteristics

	UFR30	UFR31	UFR32	
Average forward current	$I_{F(AV)}$ 30A	30A	30A	Square wave, $R_{\theta JC} = 1.8^\circ C/W$
Case Temperature	T_C 127°C	110°C	107°C	
Maximum surge current	I_{FSM} 500A	400A	300A	8.3 ms, half sine, $T_J = 175^\circ C$
Max peak forward voltage	V_{FM} .975V	1.25V	1.35V	$I_{FM} = 30A: T_J = 25^\circ C^*$
Max reverse recovery time	t_{RR} 35 ns	50 ns	60 ns	1/2A, 1A, 1/4A, $T_J = 25^\circ C$
Max peak reverse current	I_{RM} _____	1.0 mA	_____	$V_{RRM}, T_J = 125^\circ C$
Max peak reverse current	I_{RM} _____	15 μA	_____	$V_{RRM}, T_J = 25^\circ C$
Typical Junction Capacitance	C_J 140 pF	115 pF	100 pF	$V_R = 10V, f = 1MHz, T_J = 25^\circ C$

*Pulse test: Pulse width 300 μsec , Duty cycle 2%

Thermal and Mechanical Characteristics

Storage temp range	TSTG	-65°C to 175°C
Operating junction temp range	T_J	-65°C to 175°C
Max thermal resistance	$R_{\theta JC}$	1.8°C/W Junction to Case
Typical thermal resistance	$R_{\theta JC}$	1.3°C/W Junction to Case
Typical thermal resistance (greased)	$R_{\theta CS}$	0.4°C/W Case to sink
Mounting torque		12-15 inch pounds
Weight		0.2 ounces (6.0 grams) typical

UFR30

Figure 1
Typical Forward Characteristics

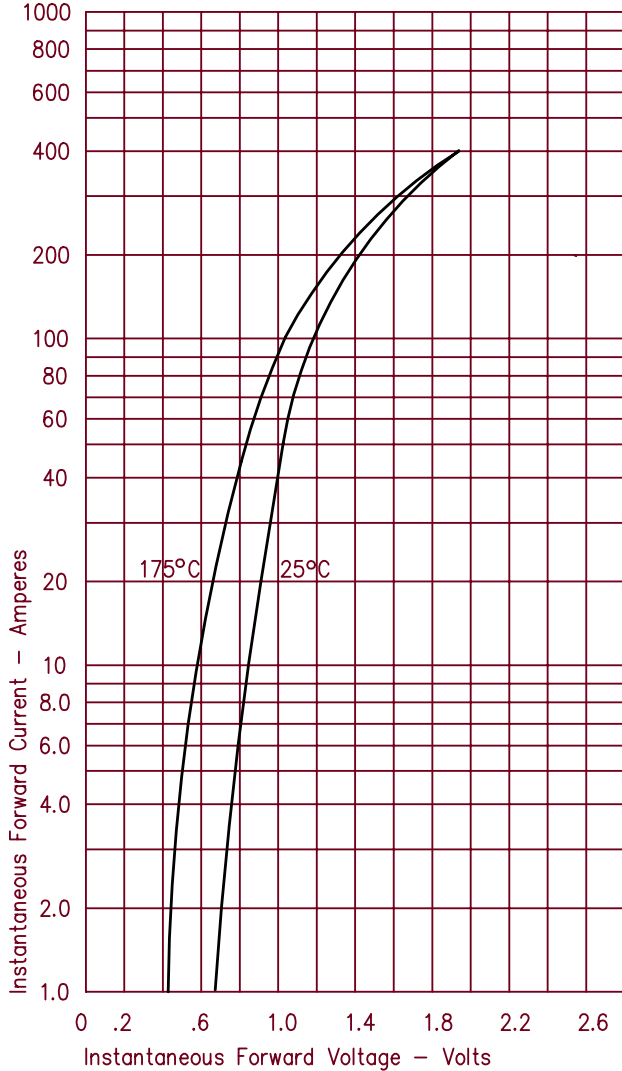

Figure 3
Typical Junction Capacitance

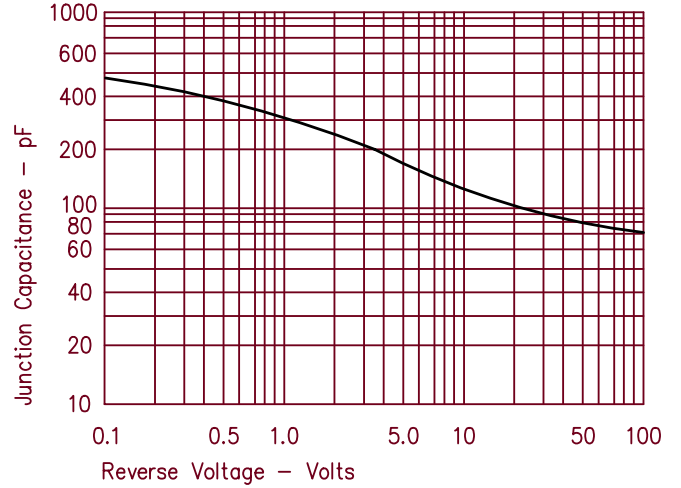

Figure 4
Forward Current Derating

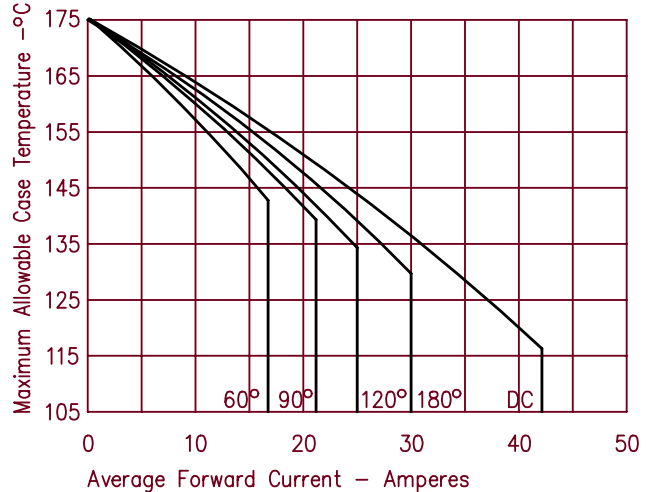

Figure 2
Typical Reverse Characteristics

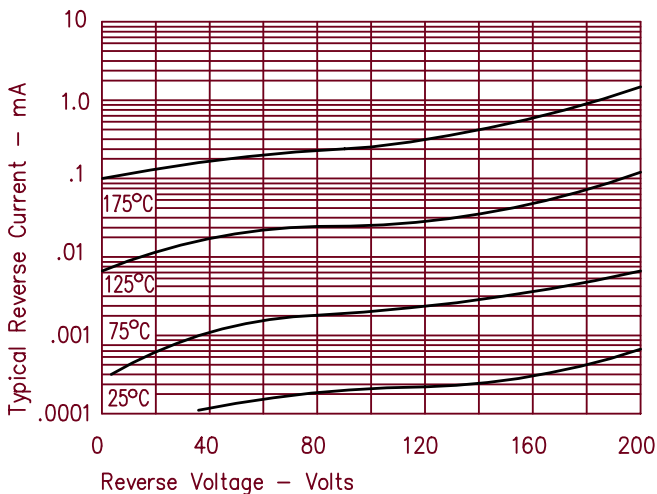
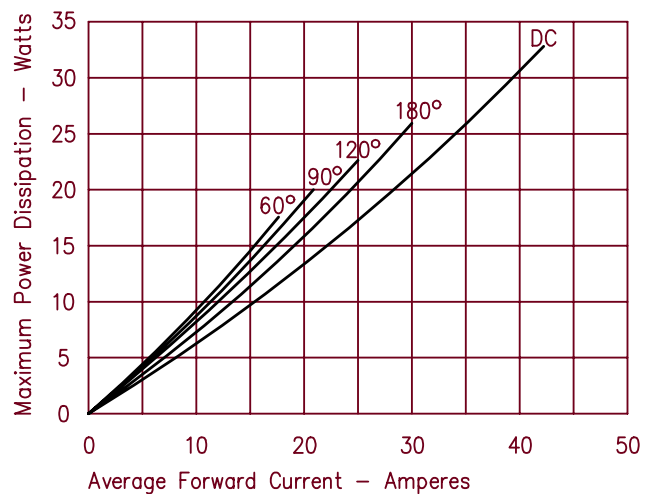

Figure 5
Maximum Forward Power Dissipation



UFR31

Figure 1
Typical Forward Characteristics

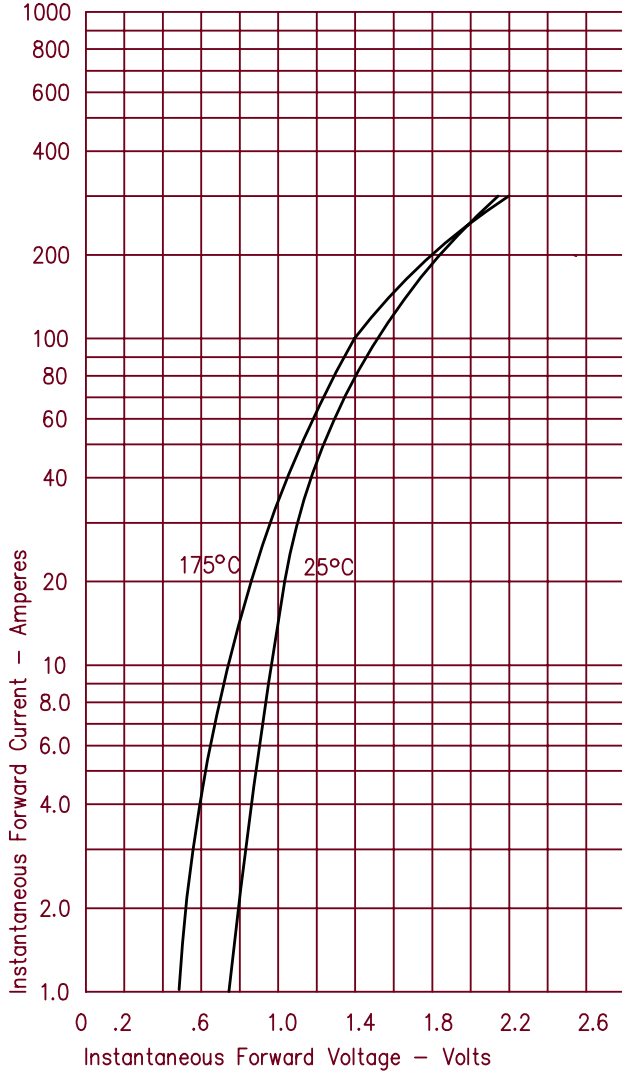

Figure 3
Typical Junction Capacitance

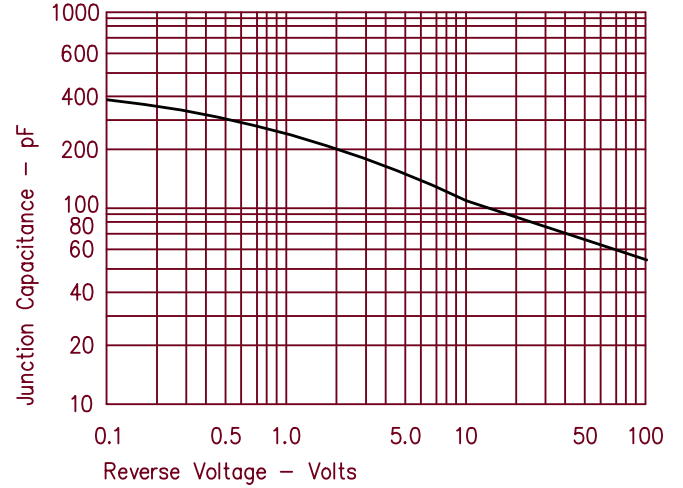

Figure 4
Forward Current Derating

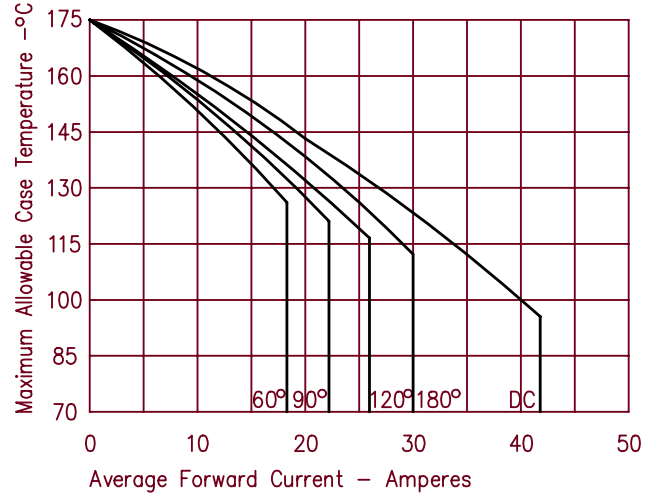

Figure 2
Typical Reverse Characteristics

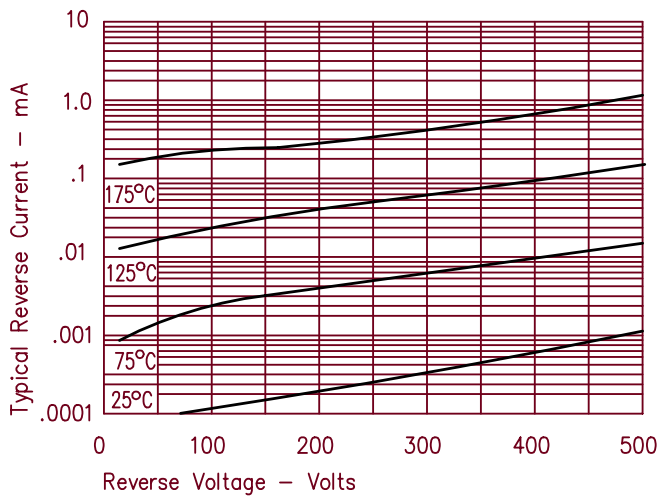
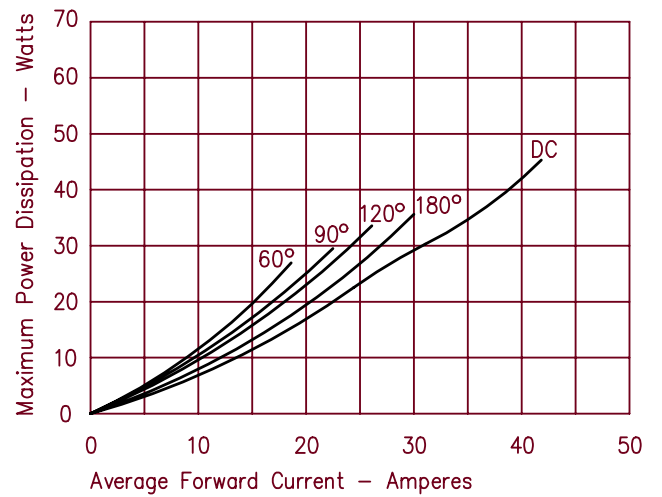

Figure 5
Maximum Forward Power Dissipation



UFR32

Figure 1
Typical Forward Characteristics

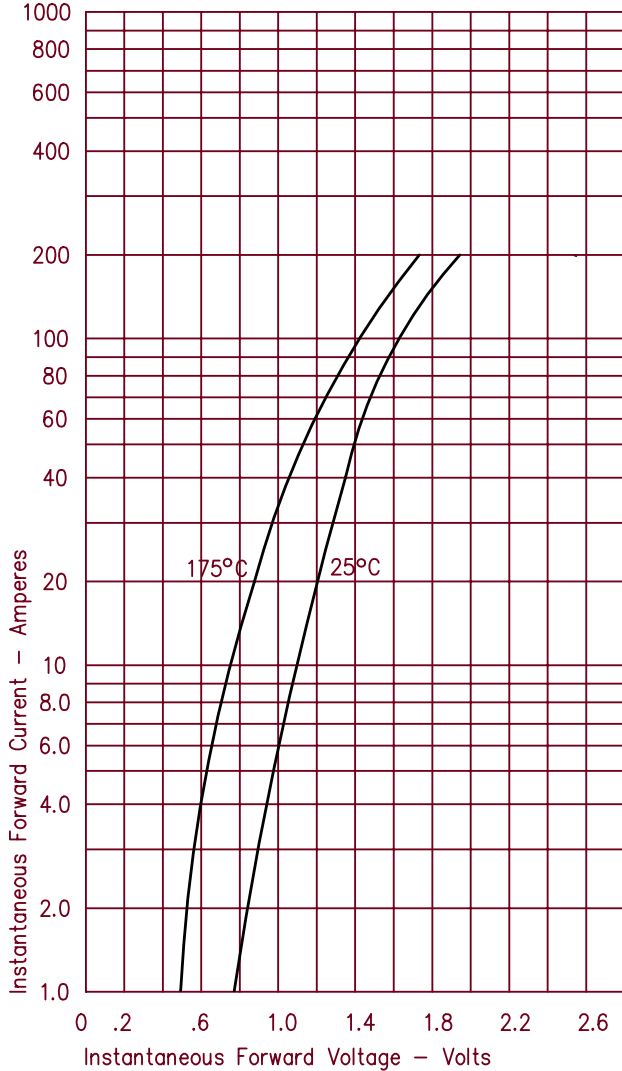

Figure 3
Typical Junction Capacitance

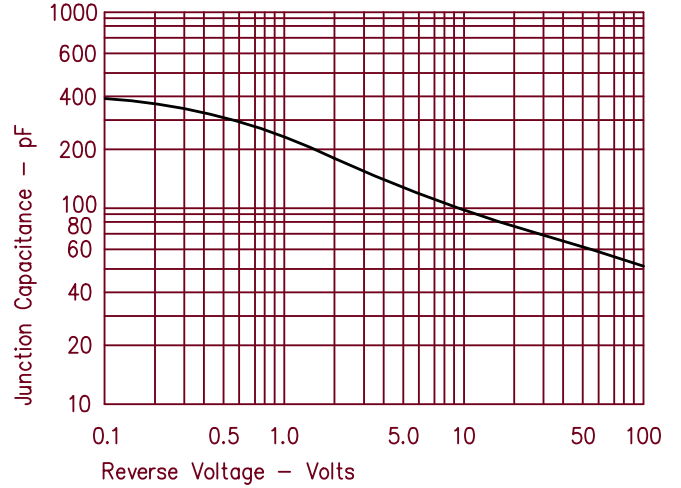

Figure 4
Forward Current Derating

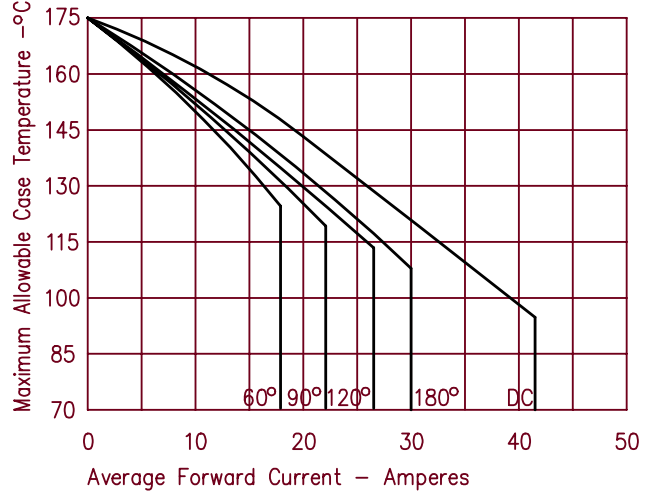

Figure 2
Typical Reverse Characteristics

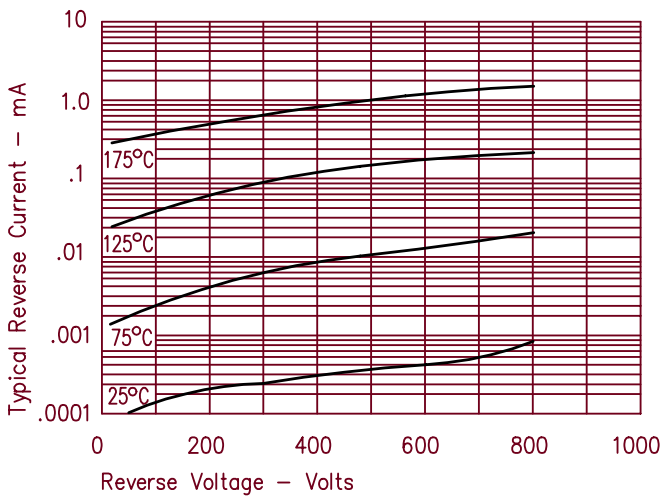

Figure 5
Maximum Forward Power Dissipation

