

RECTIFIERS

Super-Fast Recovery, 3 Amp and 4 Amp

UTX 3105-UTX 3120
UTX 4105-UTX 4120

FEATURES

- Continuous Rating: to 4A
- Controlled Avalanche
- Surge: to 80A
- Recovery Time less than 100ns
- Miniature Package

DESCRIPTION

These miniature super-fast recovery rectifiers permit operation at full power at frequencies as high as 100kHz square wave. They have the same unique Microsemi construction as the familiar 2 amp UTX series, but are scaled up in size to provide higher continuous and surge current capability.

ABSOLUTE MAXIMUM RATINGS

Peak Inverse Voltage	3 Amp Series	4 Amp Series
50V	UTX 3105	UTX 4105
100V	UTX 3110	UTX 4110
150V	UTX 3115	UTX 4115
200V	UTX 3120	UTX 4120

	3 AMP SERIES	4 AMP SERIES
Maximum Average D.C. Output Current		
@ $T_A = 25^\circ\text{C}$	3.0A	4.0A
@ $T_A = 100^\circ\text{C}$	1.5A	2.0A
Non-Repetitive Sinusoidal		
Surge Current (8.3ms)	60A	80A
Operating Temperature Range	-195°C to +175°C	
Storage Temperature Range	-195°C to +200°C	
Thermal Resistance	See Lead Temperature Derating Curve	

MECHANICAL SPECIFICATIONS

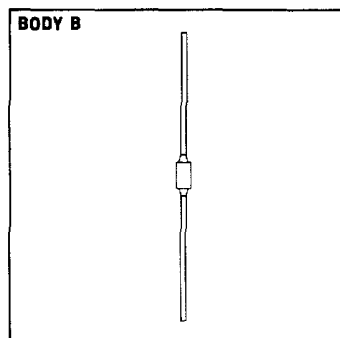
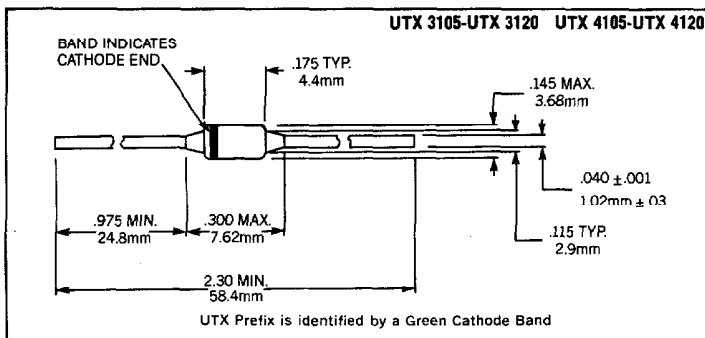

Microsemi Corp.
Watertown
The diode experts

ELECTRICAL SPECIFICATIONS (at 25°C unless noted)

2

Type	PIV	Maximum Forward Voltage Drop*	Maximum Leakage Current @ PIV		Maximum Reverse Recovery Time**
			25°C	100°C	
UTX 4105 UTX 4110 UTX 4115 UTX 4120	50V 100V 150V 200V	1V @ 3 Adc	5 μ A	75 μ A	100ns
UTX 3105 UTX 3110 UTX 3115 UTX 3120	50V 100V 150V 200V	1V @ 2 Adc	5 μ A	75 μ A	100ns

*Forward voltage is measured at least 1 second after application of current.
 **Recovery time is measured from 1A to 1A recovering to 0.5A.

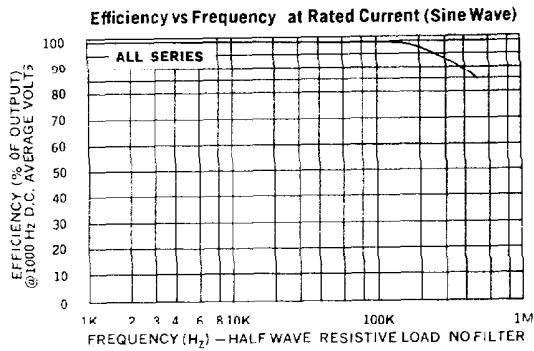
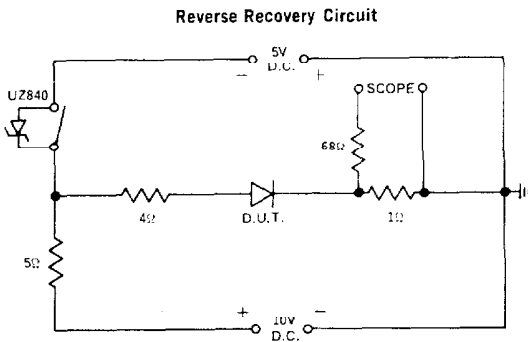
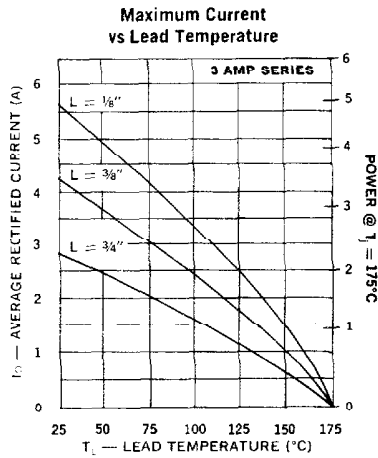
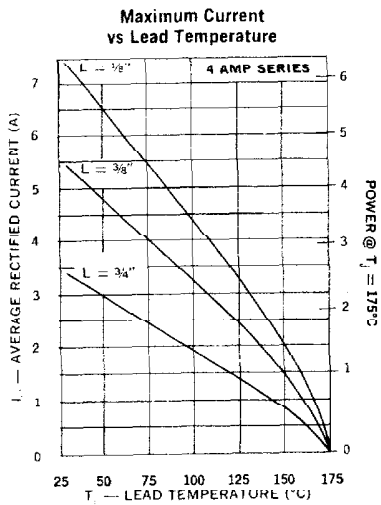

Typical Leakage Current vs PIV

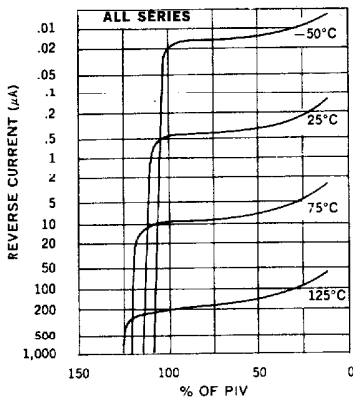

Typical Forward Current vs Forward Voltage

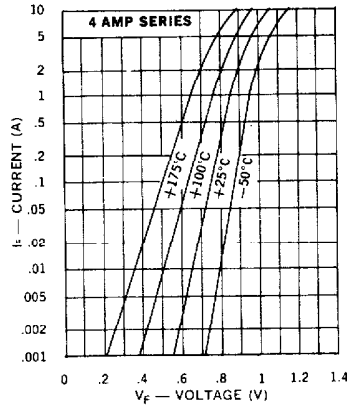

Typical Forward Current vs Forward Voltage

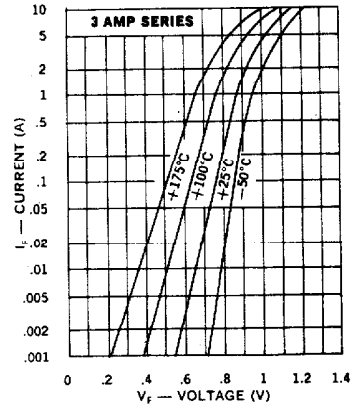

Forward Pulse Current vs Pulse Duration

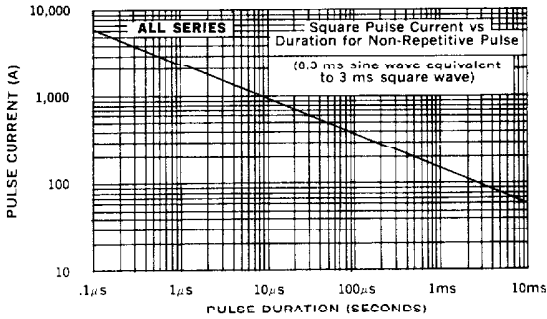

Reverse Pulse Power vs Pulse Duration

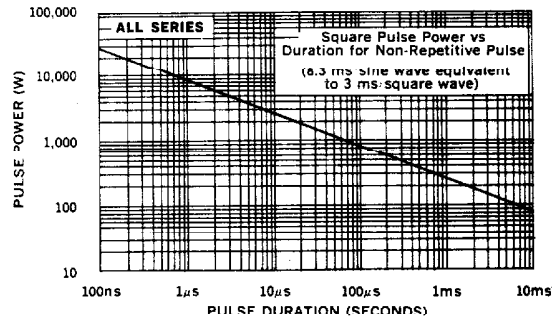

Allowable Forward Surge vs Number of Cycles

