

**MRF5943, R1, R2**

**RF & MICROWAVE DISCRETE  
 LOW POWER TRANSISTORS**

Features

- Low Cost SO-8 Plastic Surface Mount Package.
- S-Parameter Characterization
- Tape and Reel Packaging Options Available
- Maximum Available Gain = 17dB @ 300MHz



R1 suffix–Tape and Reel, 500 units  
 R2 suffix–Tape and Reel, 2500 units

DESCRIPTION: Designed for general-purpose RF amplifier applications, such as; pre-drivers, drivers, Oscillators, etc.

ABSOLUTE MAXIMUM RATINGS (Tcase = 25°C)

Symbol	Parameter	Value	Unit
V <sub>CEO</sub>	Collector-Emitter Voltage	30	Vdc
V <sub>CBO</sub>	Collector-Base Voltage	40	Vdc
V <sub>EBO</sub>	Emitter-Base Voltage	3.5	Vdc
I <sub>C</sub>	Collector Current	400	mA

Thermal Data

P <sub>D</sub>	Total Device Dissipation @ TC = 25°C Derate above 25°C	1.0 8	Watts mW/ °C
T <sub>stg</sub>	Storage Temperature	150	°C
R <sub>θJA</sub>	Thermal Resistance, Junction to Ambient	125	°C/W

ELECTRICAL SPECIFICATIONS (Tcase = 25°C)

STATIC  
 (off)

Symbol	Test Conditions	Value			Unit
		Min.	Typ.	Max.	
BVCEO	Collector-Emitter Breakdown Voltage (IC = 5.0 mAdc, IB = 0)	30	-	-	Vdc
BVCBO	Collector-Base Breakdown Voltage (IC = 0.1 mAdc, IE = 0)	40	-	-	Vdc
BVEBO	Emitter-Base Breakdown Voltage (IE = 0.1 mAdc, IC = 0)	3.5	-	-	Vdc
ICBO	Collector Cutoff Current (VCB = 20 Vdc, VBE = 0 Vdc)	-	-	.01	mA
ICEO	Collector Cutoff Current (VCE = 20 Vdc, VBE = 0 Vdc)	-	-	.05	mA

(on)

HFE	DC Current Gain (IC = 50 mAdc, VCE = 15 Vdc)	25	-	300	
VCE(sat)	Collector-emitter Saturation Voltage (IC = 100 mAdc, IB = 10 mA)			.2	Vdc
VBE(sat)	Collector-emitter Saturation Voltage (IC = 100 mAdc, IB = 10 mA)			1.0	Vdc

DYNAMIC

Symbol	Test Conditions	Value			Unit
		Min.	Typ.	Max.	
Ftau	Current-Gain Bandwidth Product (IC = 35 mAdc, VCE = 15 Vdc, f = 100 MHz)	-	1.3	-	GHz

FUNCTIONAL

Symbol	Test Conditions	Value			Unit
		Min.	Typ.	Max.	
$G_{U\max}$	Maximum Unilateral Gain IC = 35 mAdc, VCE = 15 Vdc, f = 300 MHz	-	15	-	dB
MAG	Maximum Available Gain IC = 35 mAdc, VCE = 15 Vdc, f = 300 MHz	-	17	-	dB
$ S_{21} ^2$	Insertion Gain IC = 35 mAdc, VCE = 15 Vdc, f = 300 MHz	11.5	12.5	-	dB

Table 1. Common Emitter S-Parameters, @ VCE = 15 V, IC = 35 mA

f (MHz)	S11		S21		S12		S22	
	S11	$\angle \phi$	S21	$\angle \phi$	S12	$\angle \phi$	S22	$\angle \phi$
10	0.606	-61	54.49	152	0.006	67	0.87	-20
30	0.618	-120	35.44	122	0.013	47	0.579	-31
50	0.626	-140	24.09	108	0.015	44	0.441	-35
70	0.637	-151	17.89	101	0.017	44	0.377	-33
100	0.648	-160	12.8	94	0.02	47	0.335	-29
300	0.691	-178	4.3	74	0.04	57	0.313	-31
500	0.713	172	2.53	61	0.056	58	0.348	-44
700	0.719	161	1.79	50	0.07	59	0.391	-58
1000	0.722	153	1.22	35	0.09	62	0.449	-75

**MRF5943, R1, R2**

RF Low Power PA, LNA, and General Purpose Discrete Selector Guide

Package	Device	Type	Freq (MHz)	Pout (watts)	GPE (dB)	Efficiency (%)	GPE VCC	BVCEO	IC max (mA)
SO-8	MRF4427, R2	NPN	175	0.15	18	60	12	20	400
TO-39	2N4427	NPN	175	1	10	50	12	20	400
POWER MACRO	MRF553	NPN	175	1.5	11.5	60	12.5	16	500
POWER MACRO	MRF553T	NPN	175	1.5	11.5	50	12.5	16	500
TO-39	MRF607	NPN	175	1.75	11.5	50	12.5	16	330
TO-39	2N6255	NPN	175	3	7.8	50	12.5	18	1000
TO-72	2N5179	NPN	200		20		6	12	50
MACRO X	MRF559	NPN	512	0.5	10	65	7.5	16	150
MACRO X	MRF559	NPN	512	0.5	13	60	12.5	16	150
TO-39	2N3866A	NPN	400	1	10	45	28	30	400
SO-8	MRF3866, R1, R2	NPN	400	1	10	45	28	30	400
POWER MACRO	MRF555	NPN	470	1.5	11	50	12.5	16	400
POWER MACRO	MRF555T	NPN	470	1.5	11	50	12.5	16	400
MACRO X	MRF559	NPN	870	0.5	6.5	70	7.5	16	150
MACRO X	MRF559	NPN	870	0.5	9.5	65	12.5	16	150
SO-8	MRF8372, R1, R2	NPN	870	0.75	8	55	12.5	16	200
POWER MACRO	MRF557	NPN	870	1.5	8	55	12.5	16	400
POWER MACRO	MRF557T	NPN	870	1.5	8	55	12.5	16	400

Package	Device	Type	Freq (MHz)	NF (dB)	NF IC (mA)	NF VCE	GN (dB)	Gu Max (dB)	Ftau (MHz)	Ccb (pF)	BVCEO	IC max (mA)
TO-39	2N5109	NPN	200	3	10	15		12	1200	3.5	20	400
TO-39	MRF5943C	NPN	200	3.4	30	15		11.4	1000			400
SO-8	MRF5943, R1, R2	NPN	200	3.4	30	15		15	1300			400
TO-72	2N5179	NPN	200	4.5	1.5	6		17	900	1	12	50
TO-72	2N2857	NPN	300	5.5	50	6		13	1600	1	15	40
TO-39	MRF517	NPN	300	7.5	50	15		5.5	4600	3	25	150
TO-72	MRF904	NPN	450	1.5	5	6		11	4000	1	15	30
TO-72	2N6304	NPN	450	5	2	5		14	1400	1	15	50
MACRO T	BFR91	NPN	500	1.9	2	5	11	16.5	5000	1	12	35
MACRO T	BFR96	NPN	500	2	10	10		14.5	500	2.6	15	100
SO-8	MRF5812, R1, R2	NPN	500	2	50	10	15.5	17.8	5000		15	200
MACRO X	MRF581A	NPN	500	2	50	10	14	15	5000		15	200
Macro	BFR90	NPN	500	2.4	2	10	15	18	5000	1	15	30
TO-72	BFY90	NPN	500	2.5	2	5		20	1300		15	50
TO-72	MRF914	NPN	500	2.5	5	10		15	4500		12	40
MACRO X	MRF581	NPN	500	2.5	50	10	15	17.8	5000		16	200
TO-39	MRF586	NPN	500	3	90	15	11	14.5	4500	2.2	17	200
MACRO X	MRF951	NPN	1000	1.3	5	6	14	17	8000	0.45	10	100
MACRO X	MRF571	NPN	1000	1.5	10	6	10		8000	1	10	70
MACRO T	BFR91	NPN	1000	2.5	2	5	8	11	5000	1	12	35
MACRO T	BFR90	NPN	1000	3	2	10	10	12.5	5000	1	15	30
TO-39	MRF545	PNP						14	1400	2	70	400
TO-39	MRF544	NPN						13.5	1500		70	400

RF (Low Power PA / General Purpose) Selection Guide

RF (LNA / General Purpose) Selection Guide

Low Cost RF Plastic Package Options

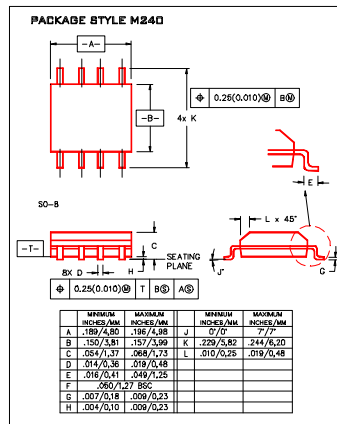
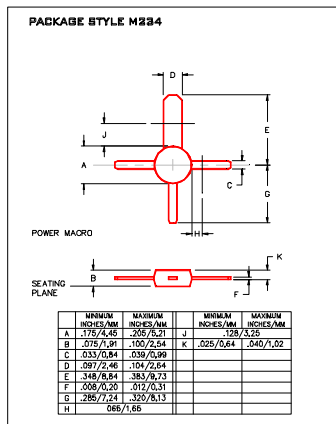
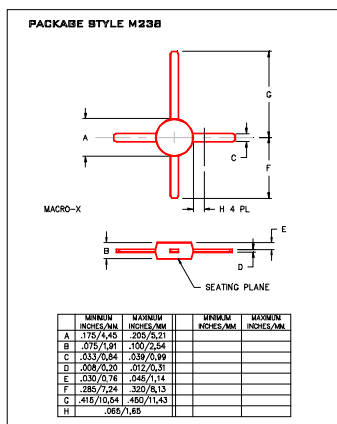
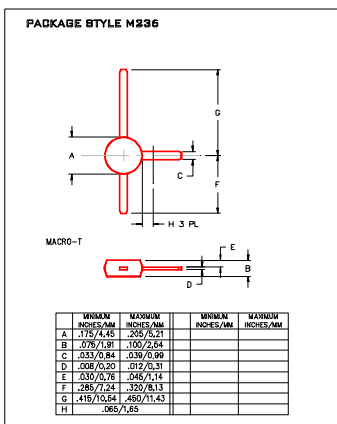

Macro T

Macro X

Power Macro

SO-8

**MRF5943, R1, R2**

