

**Features**

- DROPS HINIL LOGIC LEVELS TO LOWER LOGIC LEVELS
- INVERTING AND NONINVERTING INPUTS AVAILABLE
- SPECIFIED TO RTL AND TTL CHARACTERISTICS
- IDEAL COMPANION TO 362 OUTPUT INTERFACE

**Logic Diagrams**

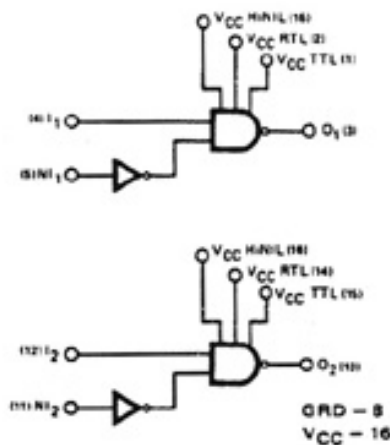

**General Description**

The 361 is used to convert HINIL logic levels to DTL, TTL and RTL logic levels. It is very simple to use, merely requiring connection to the V<sub>CC</sub> output level desired for adjustment of the output to the lower logic level.

See 362, 363 for applications information.

**Equivalent Circuit**

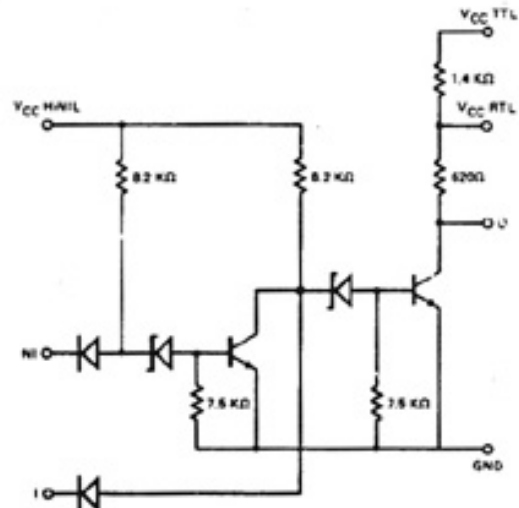

**Specifications**

SPECIFICATION AS RTL INTERFACE:  
 V<sub>CC</sub> (RTL) = 3.0 VOLTS

PARAMETER	TEMPERATURE (°C)		
	-30	+25	+70/+85
I <sub>A</sub> , min. available output current at V <sub>OUT</sub> *	-2.3 mA	-2.2 mA	-2.0 mA
V <sub>OL</sub> , max. output low voltage	350 mV	300 mV	330 mV

SPECIFICATION AS TTL INTERFACE:  
 V<sub>CC</sub> (TTL) = 4.5V

PARAMETER	TEMPERATURE (°C)		
	-30	+25	+70/+85
V <sub>OL</sub> , max. output low voltage I <sub>OL</sub> = 6.4 mA	0.4V	0.4V	0.4V
V <sub>OH</sub> , min. output high voltage I <sub>OH</sub> = -160 μA	2.4V	2.4V	2.4V

I <sub>CC</sub> (WORST-CASE)	8 mA @ 13V, 11 mA @ 16V			
t <sub>PD</sub>	230 ns	325 ns	260 ns	240 ns
I/O FUNCTION FOR t <sub>PD</sub>	A-O+	A+O+	A-O-	$\bar{A}$ +O-

Note: I<sub>CC</sub> is tested at V<sub>CC</sub> + 1 Volt (+13V for C type and +16V for A type) and is guaranteed across the applicable temp range. t<sub>PD</sub> is guaranteed at V<sub>CC</sub> ± 1V and across the applicable temp range.

See page 12 for electrical summary data.

Switching Time Waveforms

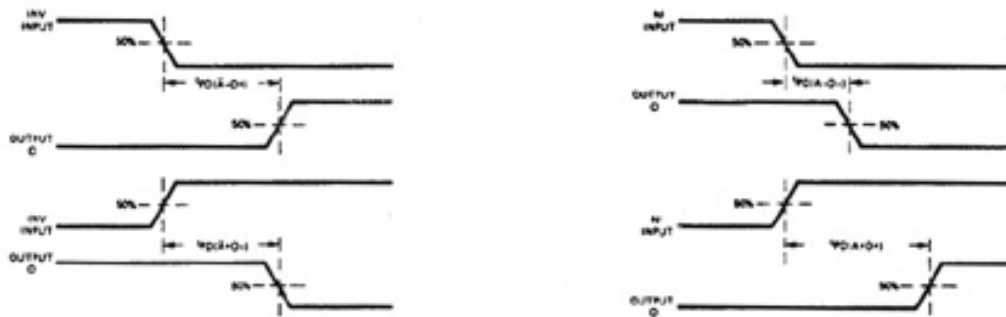

Loading Table

361

PINS	FUNCTION	LOADING
I	Inverting input	1 UL
NI	Noninverting input	1 UL
O	Output	See specifications

Typical Performance Characteristics

