

## PRECISION VOLTAGE REGULATOR

### DESCRIPTION

This monolithic voltage regulator is designed for use with either positive or negative supplies as a series, shunt, switching, or floating regulator with currents up to 150mA. Higher current requirements may be accommodated through the use of external NPN or PNP power transistors. This device consists of a temperature compensated reference amplifier, error amplifier, power series pass transistor, current limit, and remote shutdown circuitry.

The SG723 will operate over the full military ambient temperature range of -55°C to 125°C.

### FEATURES

- Positive or negative supply operation
- Series, shunt, switching or floating operation
- Low line and load regulation
- Output adjustable from 2V to 37V
- Output current to 150 mA
- Low standby current drain
- 0.002%/°C average temperature variation

### HIGH RELIABILITY FEATURES - SG723

- ◆ Available to MIL-STD-883 and DESC SMD
- ◆ MIL-M38510/10201BHA - JAN 723F
- ◆ MIL-M38510/10201BIA - JAN 723T
- ◆ MIL-M38510/10201BCA - JAN723J
- ◆ Radiation data available
- ◆ LMI level "S" processing available

### BLOCK DIAGRAM

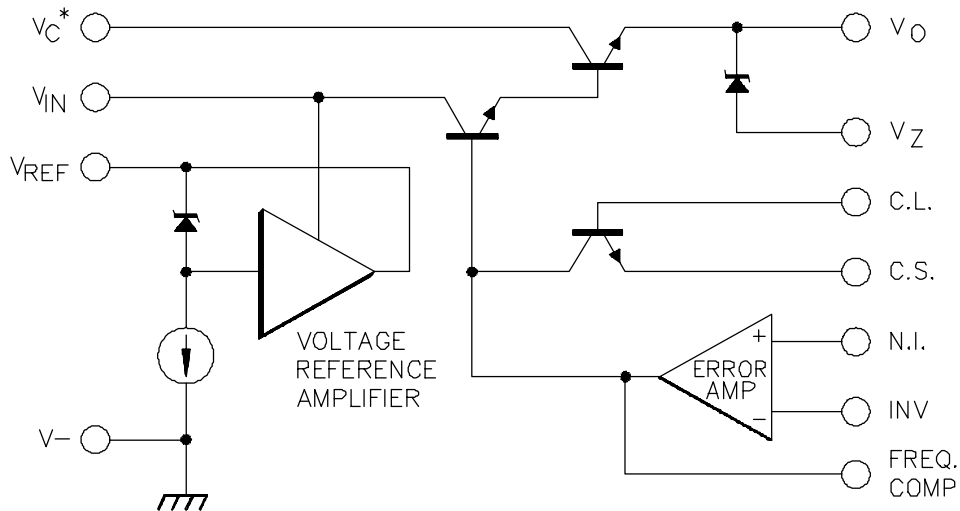

\*  $V_C$  IS INTERNALLY CONNECTED TO  $V_{IN}$  FOR T PACKAGE.

## ABSOLUTE MAXIMUM RATINGS (Note 1)

|  |       |
|--|-------|
| Pulse (50 ms) Input Voltage from $V_{IN}$ to $V_-$ ..... | 50V   |
| Continuous Input Voltage from $V_{IN}$ to $V_-$ .....    | 40V   |
| Input to Output Voltage Differential .....               | 40V   |
| Maximum Output Current .....                             | 150mA |
| Current from $V_z$ (J-Package only).....                 | 25 mA |

|  |                |
|--|----------------|
| Current from $V_{REF}$ .....                   | 15mA           |
| Operating Junction Temperature                 |                |
| Hermetic (T, J, F, L-Packages).....            | 150°C          |
| Storage Temperature Range .....                | -65°C to 150°C |
| Lead Temperature (Soldering, 10 Seconds) ..... | 300°C          |

Note 1. Exceeding these ratings could cause damage to the device.

## THERMAL DATA

J Package:

|   |        |
|---|--------|
| Thermal Resistance-Junction to Case, $\theta_{JC}$ .....    | 30°C/W |
| Thermal Resistance-Junction to Ambient, $\theta_{JA}$ ..... | 80°C/W |

T Package:

|   |         |
|---|---------|
| Thermal Resistance-Junction to Case, $\theta_{JC}$ .....    | 25°C/W  |
| Thermal Resistance-Junction to Ambient, $\theta_{JA}$ ..... | 130°C/W |

F Package:

|   |         |
|---|---------|
| Thermal Resistance-Junction to Case, $\theta_{JC}$ .....    | 80°C/W  |
| Thermal Resistance-Junction to Ambient, $\theta_{JA}$ ..... | 145°C/W |

L Package:

|   |         |
|---|---------|
| Thermal Resistance-Junction to Case, $\theta_{JC}$ .....    | 35°C/W  |
| Thermal Resistance-Junction to Ambient, $\theta_{JA}$ ..... | 120°C/W |

Note A. Junction Temperature Calculation:  $T_J = T_A + (P_D \times \theta_{JA})$ .

Note B. The above numbers for  $\theta_{JC}$  are maximums for the limiting thermal resistance of the package in a standard mounting configuration. The  $\theta_{JA}$  numbers are meant to be guidelines for the thermal performance of the device/pc-board system. All of the above assume no ambient airflow.

## RECOMMENDED OPERATING CONDITIONS (Note 2)

|                            |                              |
|----------------------------|------------------------------|
| Input Voltage Range .....  | ( $V_{OUT} + 4.5V$ ) to 38 V |
| Output Current Range ..... | 5mA to 45mA                  |
| Reference Current.....     | 5mA                          |

|                                     |                |
|-------------------------------------|----------------|
| Zener Current (J-Package only)..... | 5mA            |
| Operating Ambient Temperature Range |                |
| SG723 .....                         | -55°C to 125°C |

Note 2. Range over which the device is functional.

## ELECTRICAL CHARACTERISTICS

(Unless otherwise specified, these specifications apply for the operating ambient temperature of  $T_A = 25^\circ\text{C}$ ,  $V_{IN} = V_C = 12\text{V}$ ,  $V_- = 0\text{V}$ ,  $V_{OUT} = 5\text{V}$ ,  $I_L = 1\text{mA}$ ,  $R_{SC} = 0\Omega$ ,  $C_1 = 100\text{pF}$ , and divider impedance as seen by error amplifier  $\leq 10\text{K}\Omega$ . Low duty cycle pulse testing techniques are used which maintains junction and case temperatures equal to the ambient temperature.)

| Parameter                      | Test Conditions   | SG723 |       |       | Units               |
|--------------------------------|---|-------|-------|-------|---------------------|
|                                |   | Min.  | Typ.  | Max.  |                     |
| Input Voltage Range            |   | 9.5   |       | 40    | V                   |
| Output Voltage Range           |   | 2.0   |       | 37    | V                   |
| Input to Output Differential   |   | 3.0   |       | 38    | V                   |
| Line Regulation (Note 3)       | $V_{IN} = 12\text{V to }15\text{V}$<br>$T_A = T_{MIN} \text{ to } T_{MAX}$<br>$V_{IN} = 12\text{V to }40\text{V}$ |       | 0.01  | 0.1   | % $V_{OUT}$         |
|                                |   |       |       | 0.3   | % $V_{OUT}$         |
| Load Regulation (Note 3)       | $I_L = 1 \text{ to } 50 \text{ mA}$<br>$T_A = T_{MIN} \text{ to } T_{MAX}$  |       | 0.02  | 0.2   | % $V_{OUT}$         |
|                                |   |       | 0.03  | 0.15  | % $V_{OUT}$         |
|                                |   |       |       | 0.6   | % $V_{OUT}$         |
| Ripple Rejection               | $f = 50 \text{ Hz to } 10\text{KHz}$<br>$C_{REF} = 0$   |       | 74    |       | dB                  |
|                                | $C_{REF} = 5\mu\text{F}$  |       | 86    |       | dB                  |
| Temperature Stability (Note 4) | $T_A = T_{MIN} \text{ to } T_{MAX}$   |       | 0.002 | 0.015 | %/ $^\circ\text{C}$ |
| Short Circuit Current Limit    | $R_{SC} = 10\Omega$   |       | 65    |       | mA                  |
| Reference Voltage              |   | 6.95  | 7.15  | 7.35  | V                   |
| Output Noise Voltage           | $BW = 100\text{Hz to } 10\text{KHz}$<br>$C_{REF} = 0$   |       | 20    |       | $\mu\text{V}_{rms}$ |
|                                | $C_{REF} = 5\mu\text{F}$  |       | 2.5   |       | $\mu\text{V}_{rms}$ |
| Standby Current Drain          | $I_L = 0, V_{IN} = 30\text{V}$  |       | 2.3   | 3.5   | mA                  |
| Long Term Stability            |   |       | 0.1   |       | %/Khr               |

Note 3. Applies for constant junction temperature. Temperature drift effects must be taken into account separately when the unit is operating under conditions of high dissipation.

Note 4. These parameters, although guaranteed, are not tested in production.

CHARACTERISTIC CURVES

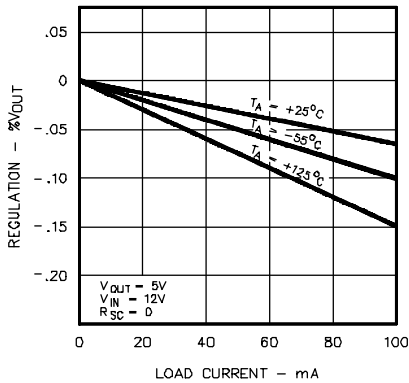

FIGURE 1. LOAD REGULATION

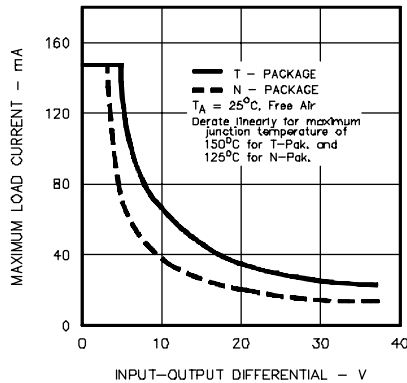

FIGURE 2. MAXIMUM LOAD CURRENT

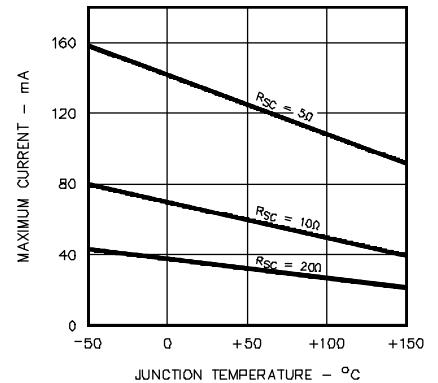

FIGURE 3. CURRENT LIMITING CHARACTERISTICS

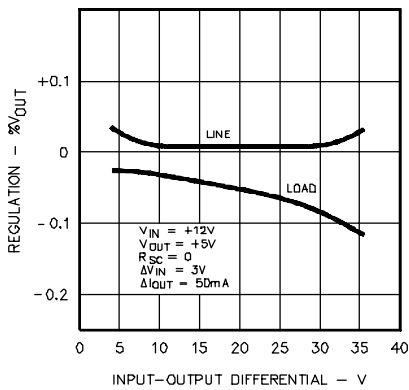

FIGURE 4. REGULATION VS. INPUT-OUTPUT VOLTAGE REGULATION

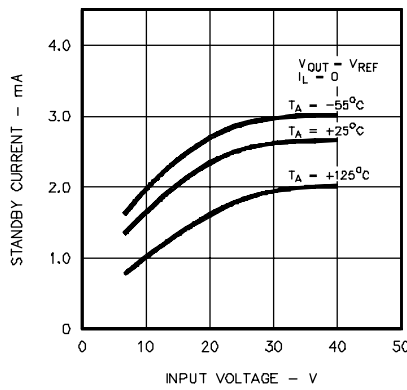

FIGURE 5. STANDBY CURRENT DRAIN

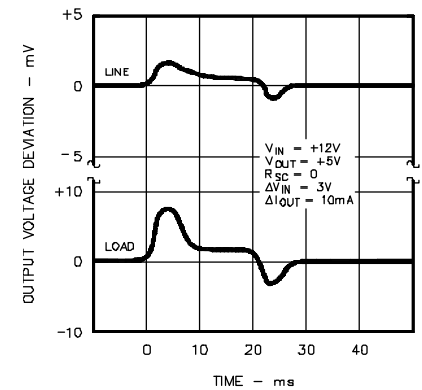

FIGURE 6. TRANSIENT RESPONSE

APPLICATION INFORMATION

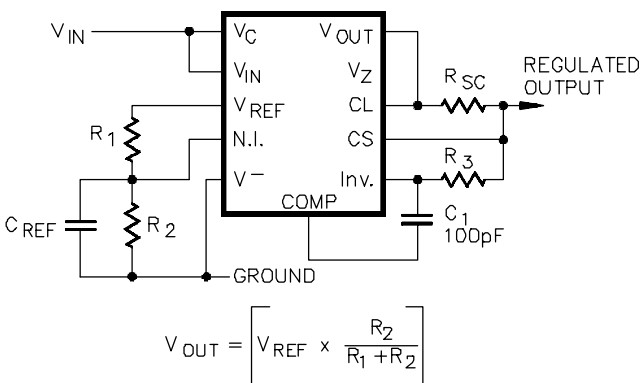

FIGURE 7 - BASIC LOW VOLTAGE REGULATOR  
 $V_{OUT} = 2\text{V TO } 7\text{V}$

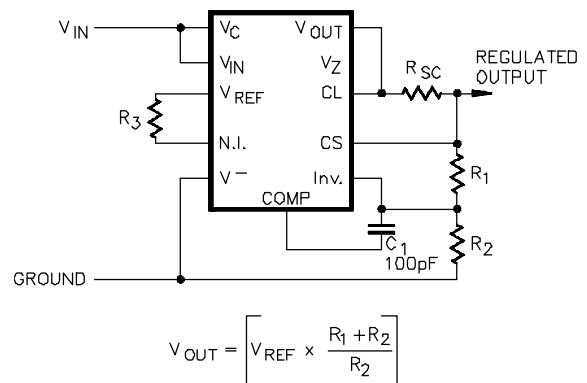

FIGURE 8 - BASIC HIGH VOLTAGE REGULATOR  
 $V_{OUT} = 7\text{V TO } 37\text{V}$

APPLICATION INFORMATION (continued)

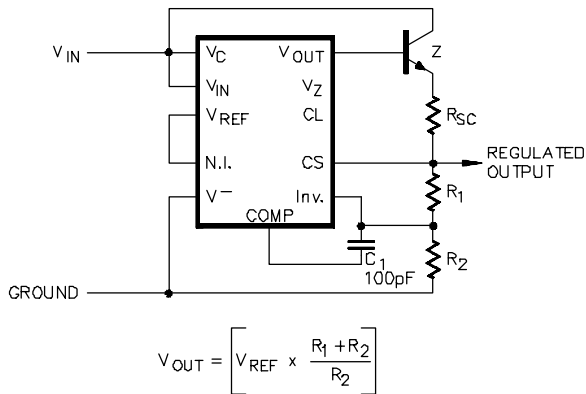

FIGURE 9 - HIGH CURRENT REGULATOR  
EXTERNAL NPN TRANSISTOR  $I_L = 1.0A$

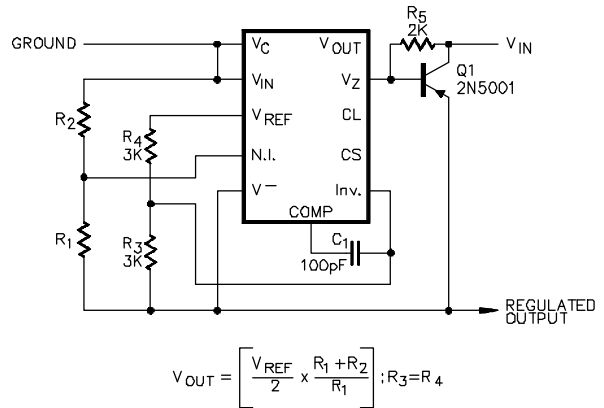

FIGURE 10 - NEGATIVE VOLTAGE REGULATOR

CONNECTION DIAGRAMS & ORDERING INFORMATION (See Notes Below)

| Package  | Part No.                         | Ambient Temperature Range                          | Connection Diagram   |
|--|----------------------------------|--|--|
| 14-PIN CERAMIC DIP<br>J - PACKAGE                      | SG723J/883B<br>JAN723J<br>SG723J | -55°C to 125°C<br>-55°C to 125°C<br>-55°C to 125°C |  |
| 10-PIN METAL CAN<br>T - PACKAGE                        | SG723T/883B<br>JAN723T<br>SG723T | -55°C to 125°C<br>-55°C to 125°C<br>-55°C to 125°C | <p>(Notes 3 &amp; 4)</p>   |
| 10-PIN CERAMIC<br>FLAT PACK<br>F - PACKAGE             | JAN723F                          | -55°C to 125°C                                     | <p>(Note 3)</p>  |
| 20-PIN CERAMIC<br>LEADLESS CHIP CARRIER<br>L - PACKAGE | SG723L/883B<br>SG723L            | -55°C to 125°C<br>-55°C to 125°C                   | <p>1. FREQ. COMP.<br/>2. CURRENT LIMIT<br/>3. CURRENT SENSE<br/>4. N.C.<br/>5. INVERTING INPUT<br/>6. N.C.<br/>7. N. I. INPUT<br/>8. VREF<br/>9. N.C.<br/>10. V-</p> |

Note 1. Contact factory for JAN and DESC product availability.  
2. All packages are viewed from the top.

Note 3.  $V_z$  output is not available in T, F-packages.  
4. Pin 5 is connected to case.