

**1K x 8-BIT STATIC RAM
MK4801A(P/J/N)-1/2/3/4**
FEATURES

- Static operation
- Organization: 1K x 8 bit RAM JEDEC pinout
- High performance
- Pin compatible with Mostek's BYTEWYDE™ memory family
- 24/28 pin ROM/PROM compatible pin configuration
- CE and OE functions facilitate bus control

DESCRIPTION

The MK4801A uses Mostek's advanced circuit design techniques to package 8,192 bits of static RAM on a single chip. Static operation is achieved with high performance and low power dissipation by utilizing Address Activated™ circuit design techniques.

BLOCK DIAGRAM

Figure 1

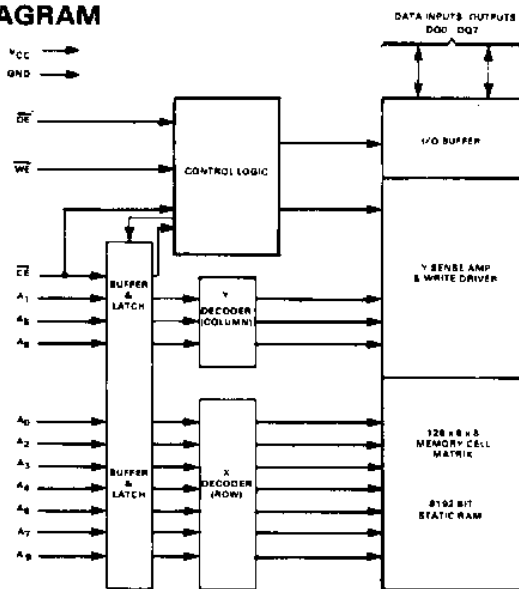

□ MKB version screened to MIL-STD-883

Part No.	R/W Access Time	R/W Cycle Time
MK4801A-1	120 nsec	120 nsec
MK4801A-2	150 nsec	150 nsec
MK4801A-3	200 nsec	200 nsec
MK4801A-4	250 nsec	250 nsec

The MK4801A excels in high speed memory applications where the organization requires relatively shallow depth with a wide word format. The MK4801A presents to the user a high density cost effective N-MOS memory with the performance characteristics necessary for today's micro-processor applications.

PIN CONNECTIONS

Figure 2

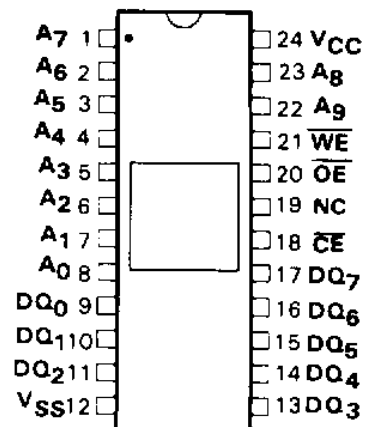
TRUTH TABLE

CE	OE	WE	Mode	DQ
V _{IH}	X	X	Deselect	High Z
V _{IL}	X	V _{IL}	Write	D _{IN}
V _{IL}	V _{IL}	V _{IH}	Read	D _{OUT}
V _{IL}	V _{IH}	V _{IH}	Read	High Z

X = Don't Care

PIN NAMES

A ₀ -A ₉	Address Inputs	WE	Write Enable
CE	Chip Enable	OE	Output Enable
V _{SS}	Ground	NC	No Connection
V _{CC}	Power (+5V)	DQ ₀ -DQ ₇	Data In/Data Out

ABSOLUTE MAXIMUM RATINGS*

Voltage on any pin relative to V_{SS}	-5 V to +7.0 V
Operating Temperature T_A (Ambient)	0°C to +70°C
Storage Temperature (Ambient)(Ceramic)	-65°C to +150°C
Storage Temperature (Ambient)(Plastic)	-55°C to +125°C
Power Dissipation	1 Watt
Output Current	20 mA

*Stresses greater than those listed under "Absolute Maximum Ratings" may cause permanent damage to the device. This is a stress rating only and functional operation of the device at these or any other conditions above those indicated in the operational sections of this specification is not implied. Exposure to absolute maximum rating conditions for extended periods may affect reliability.

RECOMMENDED DC OPERATING CONDITIONS⁷

(0°C ≤ T_A ≤ +70°C)

SYM	PARAMETER	MIN	TYP	MAX	UNITS	NOTES
V_{CC}	Supply Voltage	4.75	5.0	5.25	V	1
V_{SS}	Supply Voltage	0	0	0	V	1
V_{IH}	Logic "1" Voltage All Inputs	2.2		7.0	V	1
V_{IL}	Logic "0" Voltage All Inputs	-0.3		.8	V	1, 9

DC ELECTRICAL CHARACTERISTICS^{1,7}

(0°C ≤ T_A ≤ +70°C) (V_{CC} = 5.0 V ± 5%)

SYM	PARAMETER	MIN	TYP	MAX	UNITS	NOTES
I_{CC1}	Average V_{CC} Power Supply Current		50	80	mA	8
I_{IL}	Input Leakage Current (Any Input)	-10		10	μA	2
I_{OL}	Output Leakage Current	-10		10	μA	2
V_{OH}	Output Logic "1" Voltage I_{OUT} = 1 mA	2.4			V	
V_{OL}	Output Logic "0" Voltage I_{OUT} = 4 mA			0.4	V	

CAPACITANCE^{1,7}

(0°C ≤ T_A ≤ +70°C) (V_{CC} = +5.0 V ± 5%)

SYM	PARAMETER	TYP	MAX	NOTES
C_I	All pins (except D/Q)	4 pF	6 pF	
$C_{D/Q}$	D/Q pins	10 pF	12 pF	6

AC ELECTRICAL CHARACTERISTICS ^{3,4}

(0°C ≤ T_A ≤ 70°) (V_{CC} = 5.0 V ± 5%)

SYM	PARAMETER	-1		-2		-3		-4		UNITS	NOTES
		MIN	MAX	MIN	MAX	MIN	MAX	MIN	MAX		
t _{RC}	Read Cycle Time	120		150		200		250		ns	
t _{AA}	Address Access Time		120		150		200		250	ns	5
t _{CEA}	Chip Enable Access Time		60		75		100		125	ns	5
t _{CEZ}	Chip Enable Data Off Time	5	30	5	35	5	40	5	45	ns	
t _{OEa}	Output Enable Access Time		60		75		100		125	ns	5
t _{OEZ}	Output Enable Data Off Time	5	30	5	35	5	40	5	45	ns	
t _{AZ}	Address Data Off Time	10		10		10		10		ns	
t _{WC}	Write Cycle Time	120		150		200		250		ns	
t _{AS}	Address Setup Time	0		0		0		0		ns	see text
t _{AH}	Address Hold Time	40		50		65		80		ns	see text
t _{DSW}	Data To Write Setup Time	10		10		15		20		ns	
t _{DHW}	Data From Write Hold Time	10		10		10		10		ns	
t _{WD}	Write Pulse Duration	45		50		60		70		ns	see text
t _{WEZ}	Write Enable Data Off Time	5	30	5	35	5	40	5	45	ns	
t _{WPL}	Write Pulse Lead Time	75		90		130		170		ns	

NOTES:

1. All voltages referenced to V_{SS}
2. Measured with .4 ≤ V_I ≤ 5.0 V, outputs deselected and V_{CC} = 5 V
3. AC measurements assume Transition Time = 5 ns, levels V_{SS} to 3.0 V
4. Input and output timing reference levels are at 1.5 V
5. Measured with a load as shown in Figure 3.
6. Output buffer is deselected.
7. A minimum of 2ms time delay is required after application of V_{CC} (+5 V) before proper device operation can be achieved.
8. I_{CC} measured with outputs open.
9. Negative undershoots to a minimum of -1.5 V are allowed with a maximum of 50 ns pulse width.

OUTPUT LOAD

Figure 3

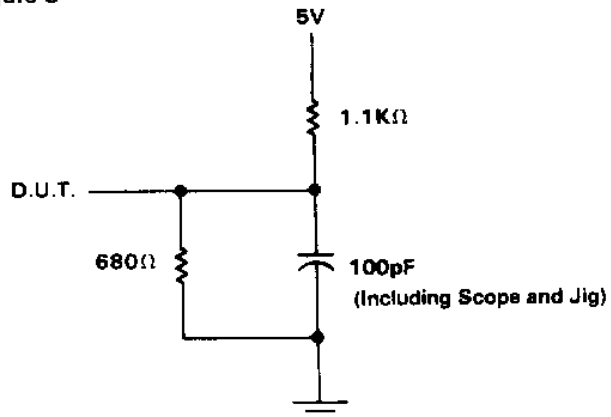

TIMING DIAGRAM

Figure 4

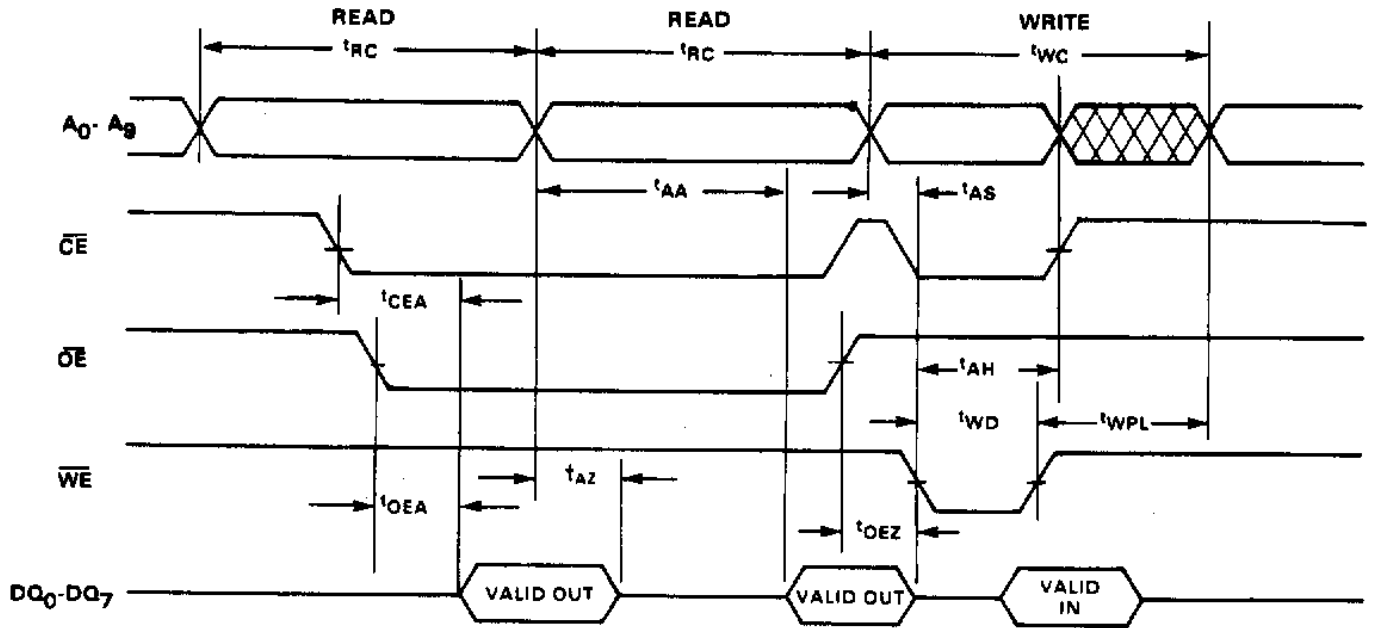

TIMING DIAGRAM

Figure 5

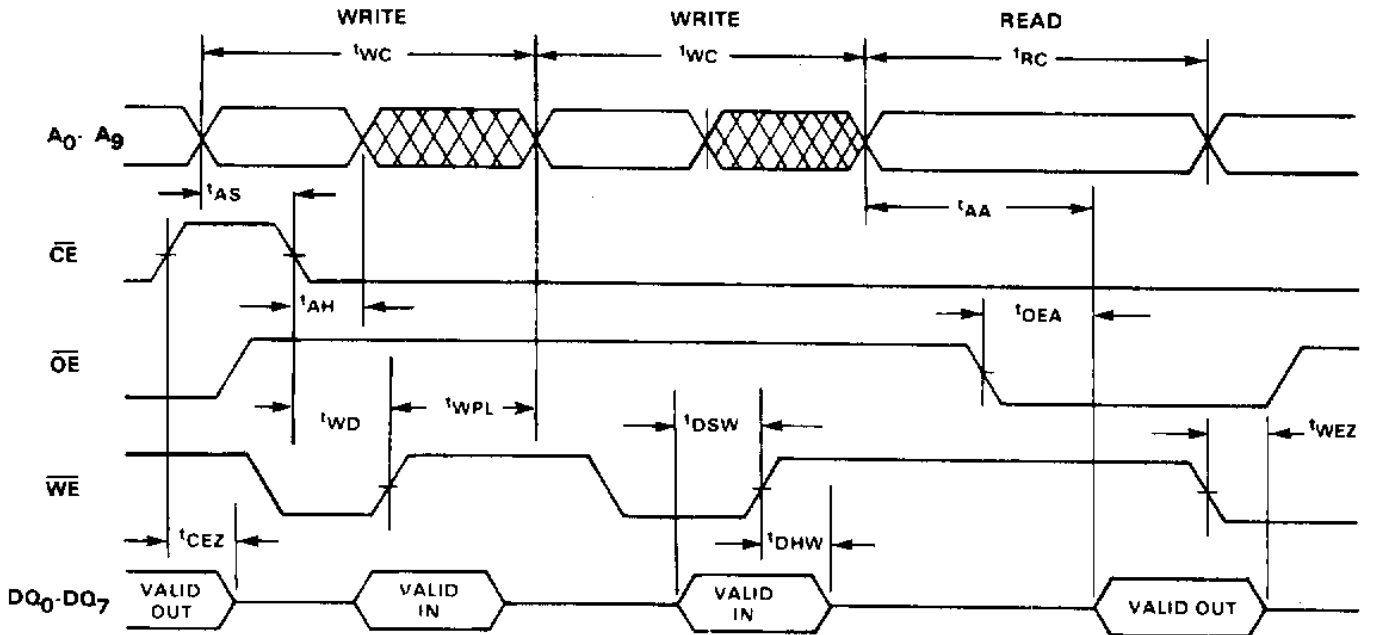

The MK4801A features a fast \overline{CE} (50% of Address Access) function to permit memory expansion without impacting system access time. A fast \overline{OE} (50% of access time) is included to permit data interleaving for enhanced system performance.

The MK4801A is pin compatible with Mostek's BYTEWYDE™ memory family of RAMs, ROMs and EPROMs. Mostek also offers a higher performance version of the MK4801A designated the MK4801A.

OPERATION

Read Mode

The MK4801A is in the READ MODE whenever the Write Enable Control input (\overline{WE}) is in the high state.

In the READ mode of operation, the MK4801A provides a fast address ripple-through access of data from 8 of 8192 locations in the static storage array. Thus, the unique address specified by the 10 Address Inputs (A_n) define which 1 of 1024 bytes of data is to be accessed.

A transition on any of the 10 address inputs will disable the 8 Data Output Drivers after t_{AZ} . Valid Data will be available to the 8 Data Output Drivers within t_{AA} after the last address input signal is stable, providing that the \overline{CE} and \overline{OE} access times are satisfied. If \overline{CE} or \overline{OE} access times are not met, data access will be measured from the limiting parameter

(t_{CEA} or t_{OEA}) rather than the address. The state of the 8 data I/O signals is controlled by the Chip Enable (\overline{CE}) and Output Enable (\overline{OE}) control signals.

Write Mode

The MK4801A is in the Write Mode whenever the Write Enable (\overline{WE}) and Chip Enable (\overline{CE}) control inputs are in the low state.

The WRITE cycle is initiated by the \overline{WE} pulse going low provided that \overline{CE} is also low. The leading edge of the \overline{WE} pulse is used to latch the status of the address bus.

NOTE: In a write cycle the latter occurring edge of either \overline{WE} or \overline{CE} will determine the start of the write cycle. Therefore, t_{AS} , t_{WD} and t_{AH} are referenced to the latter occurring edge of \overline{CE} or \overline{WE} . Addresses are latched at this time. All write cycles whether initiated by \overline{CE} or \overline{WE} must be terminated by the rising edge of \overline{WE} . If the output bus has been enabled (\overline{CE} and \overline{OE} low) then \overline{WE} will cause the output to go to the high Z state in t_{WEZ} .

Data In must be valid t_{DSW} prior to the low to high transition of \overline{WE} . The Data In lines must remain stable for t_{DHW} after \overline{WE} goes inactive. The write control of the MK4801A disables the data out buffers during the write cycle; however, \overline{OE} should be used to disable the data out buffers to prevent bus contention between the input data and data that would be output upon completion of the write cycle.