

MX•COM, INC. MiXed Signal ICs

DATA BULLETIN

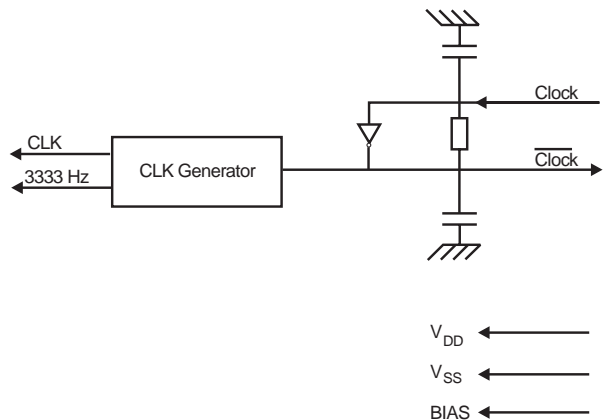
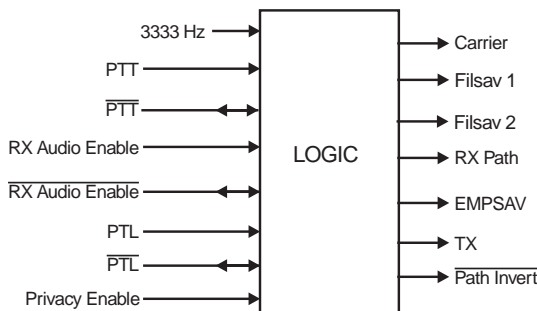
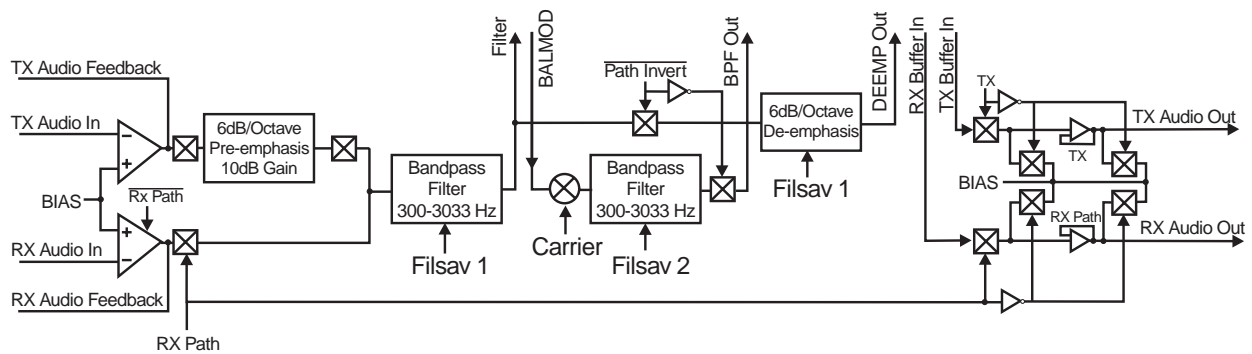
MX014 Voice Band inverter

Features

- CTCSS Compatible
- Fixed Frequency Inversion
- Low Power CMOS

Applications

- Land Mobile Radio Systems
- Community Repeaters



The MX014 Voice Band Inverter gives the security of private voice communications to land mobile radio users, as well as to the users of other shared radio channel systems. Designed for use in half-duplex systems, the MX014 exchanges high and low frequencies in the voiceband and renders transmitted messages unintelligible. This privacy function is achieved by a single frequency inversion. When used with CTCSS, **PrivSQUELCH™** privacy adapter operation is achieved.

Sharp cut-off in the internal voiceband filters permits operation with CTCSS and similar sub-audio signaling schemes. This results in high quality recovered audio.

The core of the MX014 consists of two audio band pass filters and a balanced modulator. The device uses a programmable clock divider which controls the carrier and filter cut-off frequencies. Control of the RX/TX, PTL and privacy function is by pin selection.

The MX014 operates from a single 5V supply and uses a 4 MHz crystal oscillator to ensure the correct pitch in recovered speech. Signal coupling and decoupling are the only external components needed. The device is available in 24-pin PLCC (MX014LH), 24-pin PDIP (MX014P) and 24-pin CDIP (MX014J) packages.

CONTENTS

Section	Page
1. Block Diagram	3
2. Signal List	4
3. External Components	5
4. Application	6
5. Performance Specification.....	8
5.1 Electrical Performance	8
5.1.1 Absolute Maximum Ratings	8
5.1.2 Operating Limits.....	8
5.1.3 Operating Characteristics	8
5.2 Packaging	10

MX•COM, Inc. reserves the right to change specifications at any time and without notice.

1. Block Diagram

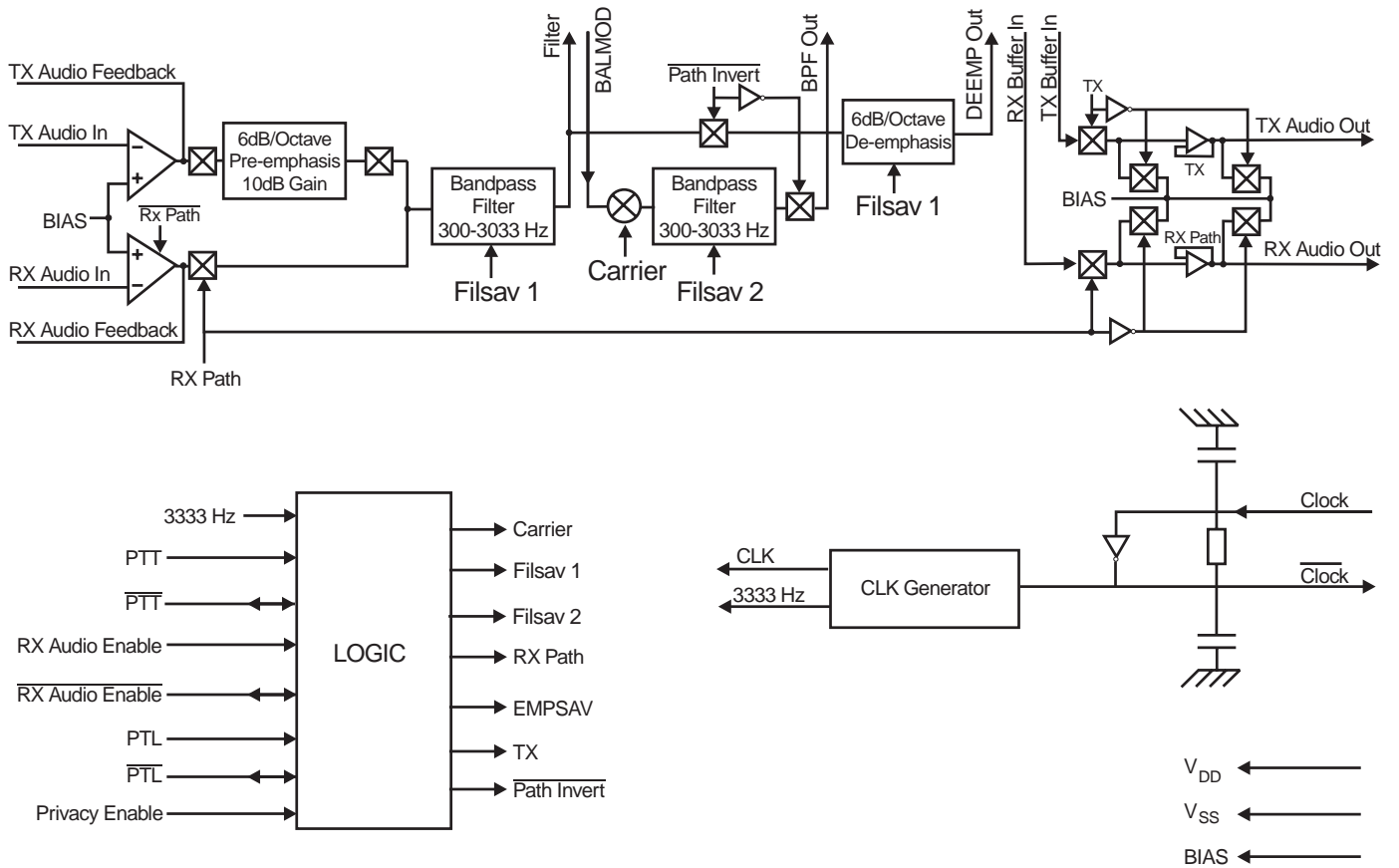


Figure 1: Device Block Diagram

2. Signal List

Pin No.	Name	Description
1	XTAL	An external 4MHz clock can be applied to this input. The clock circuit on chip has a resistor and capacitors so that only one external crystal is required.
2	$\overline{\text{XTAL}}$	This is the inverted 4MHz clock output for use when a crystal oscillator is used, or as a buffer for driving other clocked devices.
3	PTT	Push To Talk is an input with a 3M Ω pull-down resistor.
4	$\overline{\text{PTT}}$	This is the inverted PTT output. It has a 100k Ω output impedance.
5	PTL	Push To Listen is an input with a 3M Ω pull-down resistor.
6	$\overline{\text{PTL}}$	Push To Listen is the inverted output of PTL; it has a 100k Ω output impedance.
7	RXAUDEN	RX Audio Enable is an input with a 3M Ω pull-down resistor.
8	$\overline{\text{RXAUDEN}}$	RX Audio Enable is the inverted output of RX Audio Enable; it has a 100k Ω output impedance.
9	PRIVEN	Privacy Enable controls the input action of the balanced modulator by switching the carrier clock. When audio signals are inverted, the signal path gain is adjusted automatically to compensate for the upper sideband loss. It contains a 3M Ω pull-down resistor.
10	RXOUT	This is the receive audio output pin. It is biased at $V_{DD}/2$ when in the TX mode.
11	TXOUT	This is the "send" voice output pin. It is biased at $V_{DD}/2$ when in RX mode.
12	V_{SS}	The negative supply pin (ground).
13	BPFOUT	For a gain of one in the RX Output stage, these two pins are wire linked together. However, if gain is introduced at the RX input, attenuation may be introduced at the RX Output using these pins and two resistors.
14	RXBIN	
15	DEMPOUT	The pre-emphasis circuit has a 10dB gain at 1 kHz. Additional gain, or attenuation can be introduced as in the RX path.
16	TXBIN	
17	BIAS	This is the internally generated $V_{DD}/2$ decoupling pin.
18	FILTR	This filter is the output of the Input Audio BPF and must be a.c. coupled into the Balanced Modulator Input through a 0.1 μF capacitor.
19	BALMOD	This is the input to the balanced modulator. It must be a.c. coupled to the Filter Output.
20	RXIN	This is a negative input of an op-amp at the input of the RX path. It can be used, along with RX Audio Feedback and two external resistors, to increase the signal to its optimum level prior to frequency inversion/filtering. This may improve the S/N.
21	RXFB	RX Audio Feedback is the output of an op-amp at the input of the RX path. See RXIN.
22	TXIN	The negative input of an op-amp at the input of the TX path. It can be used, along with TX Audio Feedback and two external resistors, to increase the signal to its optimum level prior to frequency inversion/filtering. This may improve S/N.
23	TXFB	TX Audio Feedback is the output of an op-amp at the input of the TX path. See TXIN.
24	V_{DD}	The positive supply pin.

Table 1: Signal List

3. External Components

Configuration for Radios with Existing Pre- and De-emphasis.

For Use in Radios without Pre- and De-emphasis.

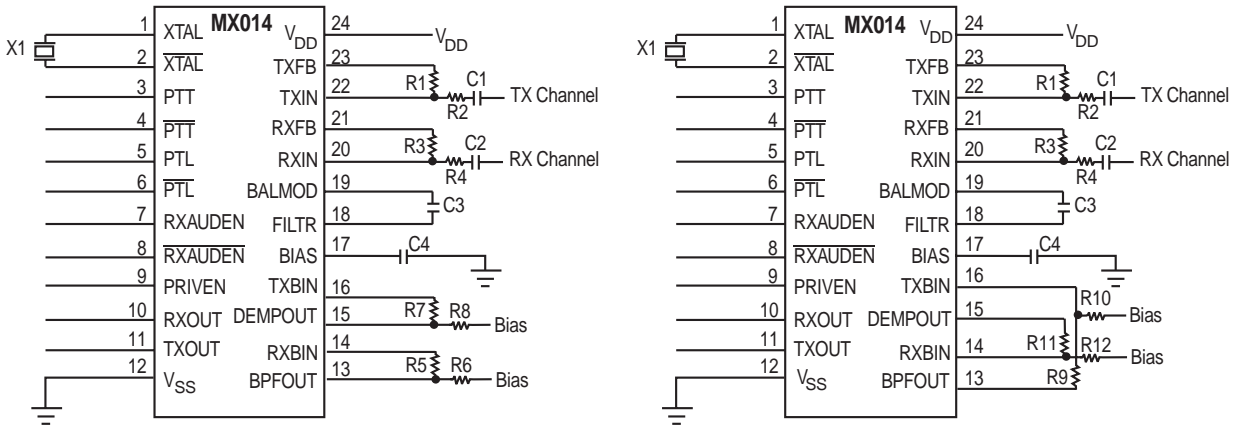


Figure 2: External Components Connections

$\text{TX Attenuation} = \frac{R8}{R7 + R8}$ <p>For a gain of 1, $R8 = \infty, R7 = 0$</p>
$\text{RX Attenuation} = \frac{R6}{R5 + R6}$ <p>For a gain of 1, $R6 = \infty, R5 = 0$</p>

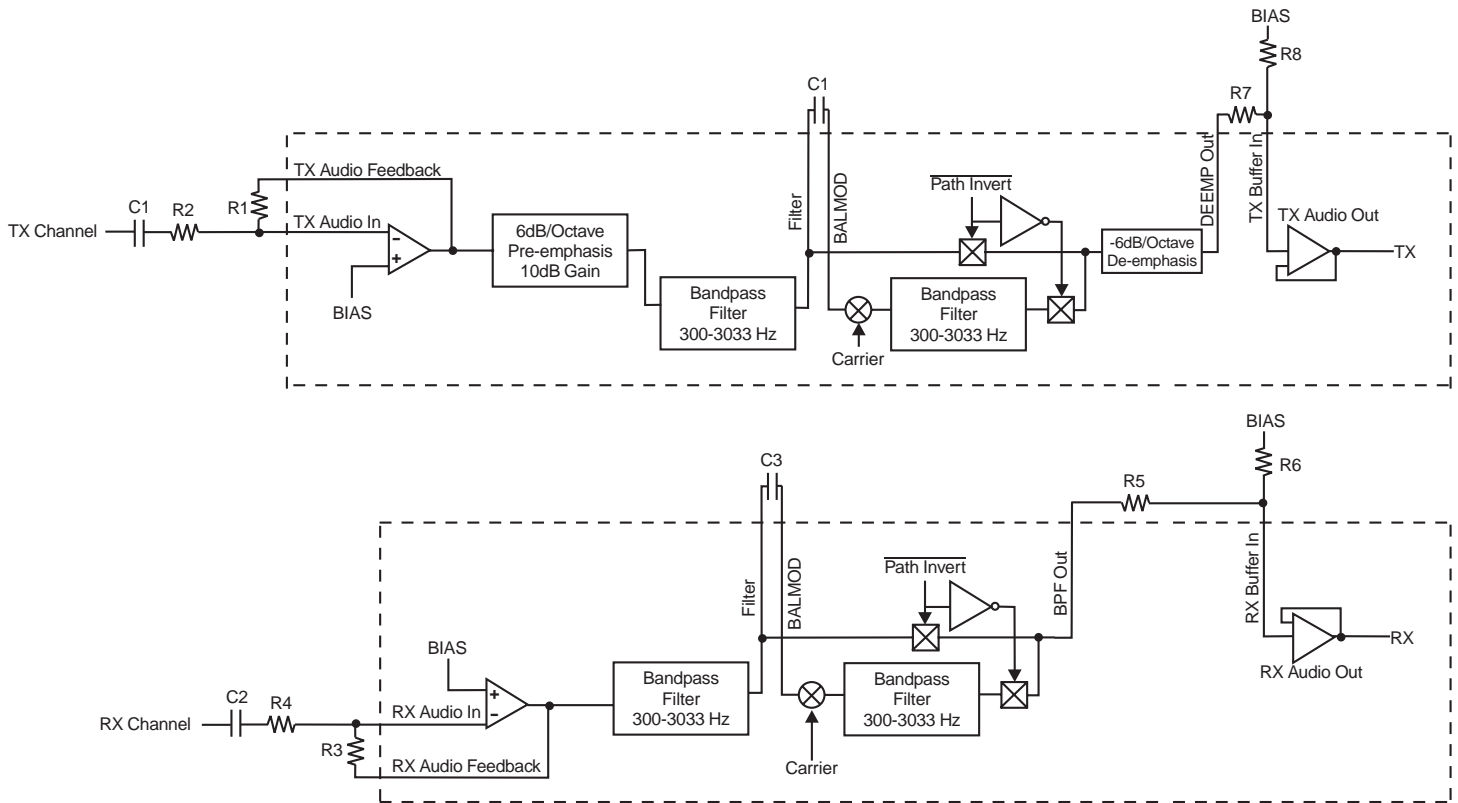
$\text{TX Attenuation} = \frac{R10}{R9 + R10}$ <p>For a gain of 1, $R9 = 0, R10 = \infty$</p>
$\text{RX Attenuation} = \frac{R12}{R11 + R12}$ <p>For a gain of 1, $R11 = 0, R12 = \infty$</p>

Table 2: Gain and Attenuation Calculations

Recommended External Component Notes:

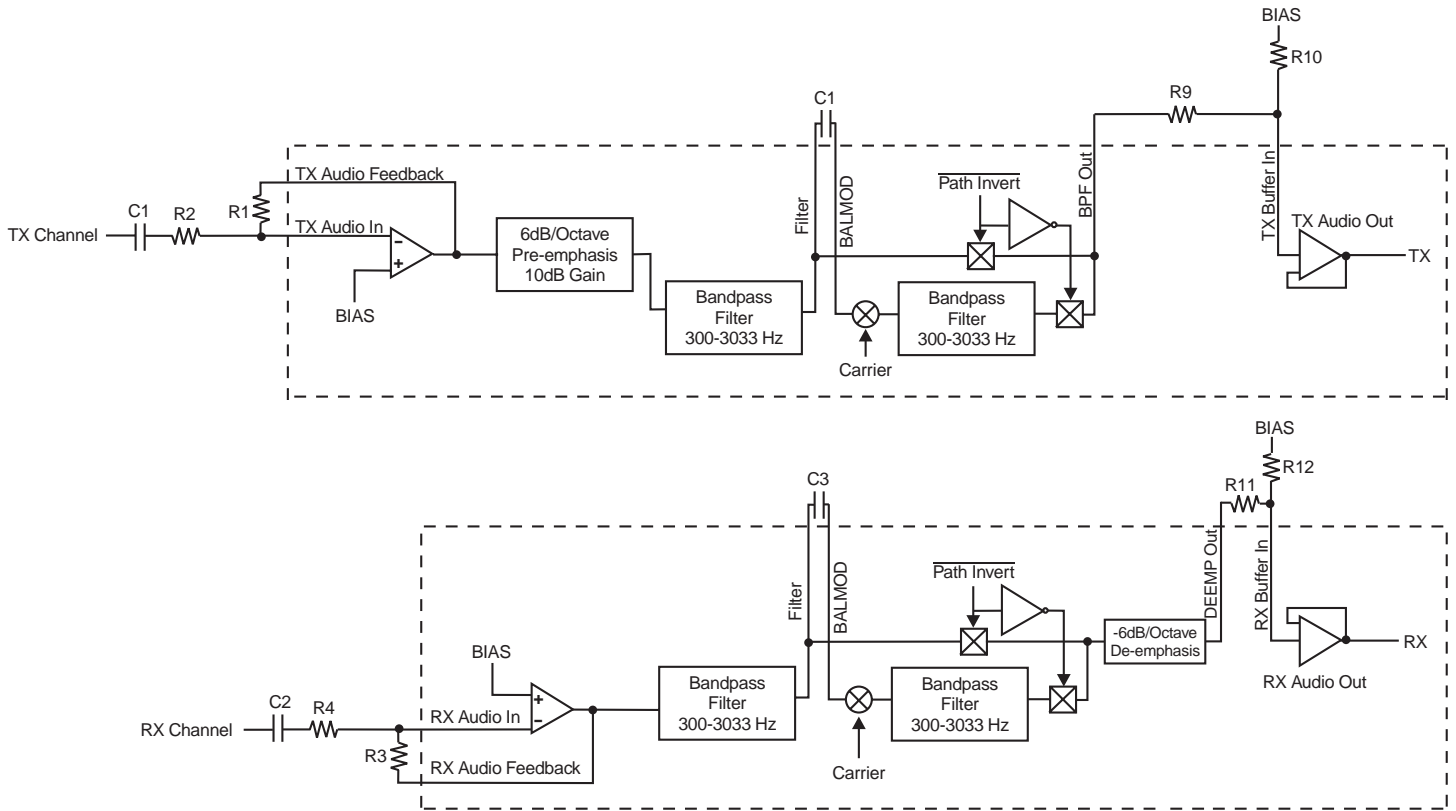
1. Component Values: C1- C3 = 0.1 μF, C4 = 1.0 μF, X1 = 4 MHz crystal
2. R1 to R12 values will depend on the configuration and the gain or attenuation required. However R1, R3, R5, R7, and R11 should be 100 kΩ or greater. To add gain or attenuate, use R5-R12 as shown. See pin descriptions for more information.
3. For best results, a crystal oscillator design should drive the clock inverter input with signal levels of at least 40% of VDD, peak to peak. Tuning fork crystals generally cannot meet this requirement. To obtain crystal oscillator design assistance, consult your crystal manufacturer.

4. Application



Note: Dotted Lines contain on-chip functions

Figure 3: Voice Privacy Application (Add-on)



Note: Dotted Lines contain on-chip functions

Figure 4: Voice Processing Application (OEM)

5. Performance Specification

5.1 Electrical Performance

5.1.1 Absolute Maximum Ratings

Exceeding these maximum ratings can result in damage to the device.

General	Min.	Max.	Units
Supply Voltage	-0.3	7.0	V
Input Voltage at any pin (ref. $V_{SS} + 0\text{ V}$)	-0.3	($V_{DD} + 0.3$)	V
Current:			
V_{DD}		30	mA
V_{SS}		30	mA
Any other pin		20	mA
J / P / LH Packages			
Maximum Device Dissipation at $T_{AMB} = 25^{\circ}\text{C}$		800	mW
Derating above 25°C		10	mW/ $^{\circ}\text{C}$ above 25°C
Operating Temperature Range:	-40	85	$^{\circ}\text{C}$
Storage Temperature Range:	-55	125	$^{\circ}\text{C}$

5.1.2 Operating Limits

Correct operation of the device outside these limits is not implied.

	Min.	Typ.	Max.	Units
V_{DD}	4.5	5.0	5.5	V
Clock Frequency		4.0		MHz
Operating Temperature	-40		85	$^{\circ}\text{C}$

5.1.3 Operating Characteristics

For the following conditions unless otherwise specified:

$V_{DD} = 5.0\text{V}$ at $T_{AMB} = 25^{\circ}\text{C}$

Clock Frequency = 4.0MHz, 0dB reference = $300\text{mV}_{\text{RMS}}$ (Note: Measured at pin 18, the FILTR output. This pin must not exceed $300\text{mV}_{\text{RMS}}$ at 1kHz in Tx and $500\text{mV}_{\text{RMS}}$ at any frequency in Rx, or clipping may occur. The difference in levels is due to the pre-emphasis filter in the Tx path.

	Notes	Min.	Typ.	Max	Units
Static Values					
Supply Current:					
RX/TX Operating (Private)				11.0	mA
RX/TX Operating (Clear)				8.0	mA
Standby	4			1.8	mA
Audio Input Impedance			10		$\text{M}\Omega$
Audio Output Impedance	5		0.5		$\text{k}\Omega$
Digital Output Impedance(Pulldown)		1			$\text{M}\Omega$
Digital I/O Impedance			100		$\text{k}\Omega$
Input Logic "1"		70%			V_{DD}
Input Logic "0"				30%	V_{DD}

	Notes	Min.	Typ.	Max	Units
RX Clear Performance					
Total Harmonic Distortion	1		2	5	%
Output Noise Level	2		2		mV _{RMS}
Passband Gain			0		dB
Passband Ripple (300-3033 Hz)	1	-3		+2	dB
Stopband Attenuation					
(fin > 3333 Hz)			20		dB
(fin > 3633 Hz)			45		dB
(fin < 250 Hz)			42		dB
RX Inverted					
Total Harmonic Distortion	1,3		4		%
Output Noise Level	2,3		4		mV _{RMS}
Passband Ripple (300 - 3033 Hz)	3			4	dB
Stopband Attenuation					
(fin > 3333 Hz)			50		dB
(fin > 3633 Hz)			60		dB
Highpass Attenuation					
(fin < 250 Hz)			60		dB
TX Clear					
Total Harmonic Distortion	1		2	5	%
Output Noise Level	2		2		mV _{rms}
Passband Gain					
(fin = 300 - 3033 Hz)	1		0		dB
Passband ripple					
(fin = 300 - 3033 Hz)	1			4	dB
Stopband Attenuation					
(fin > 3333 Hz)	2		20		dB
(fin > 3633 Hz)			45		dB
(fin < 250 Hz)			42		dB
TX Inverted					
Total Harmonic Distortion	1,3		4		%
Output Noise Level	2		4		mV _{rms}
Passband Ripple					
(fin = 300 - 3333 Hz)	1,3			4	dB
Stopband Attenuation					
(fin > 3333 Hz)	3		50		dB
(fin > 3633 Hz)	3		60		dB
(fin < 250 Hz)	3		60		dB
Pre-Emphasis					
Frequency Response			6		dB/Octave
Gain at 1 kHz			10		dB
De-emphasis					
Frequency response			-6		dB/Octave
Gain at 1 kHz			0		dB

Operating Characteristics Notes:

1. Input signal = 1kHz tone 0dB (300 mV_{RMS})
2. Input AC short circuit, audio path enabled. Measured in 30 kHz band
3. Due to frequency inversion (and pre- and de-emphasis), this refers to deviation from expected ideal response
4. Standby occurs in RX with RX Audio Enable = 0, RX Audio Enable = 1, and PTL = 1
5. TX Audio Out and RX Audio Out only

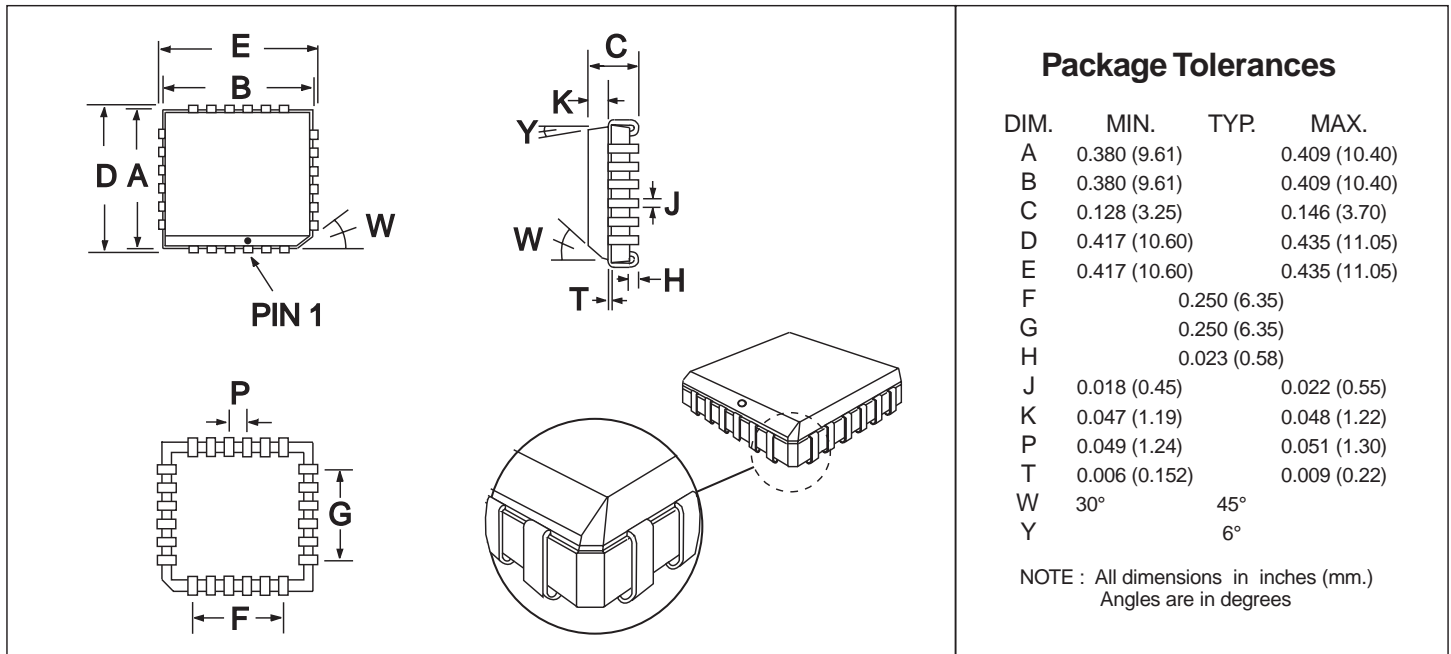
5.2 Packaging

Figure 5: 24-pin PLCC Mechanical Outline: Order as part no. MX014LH

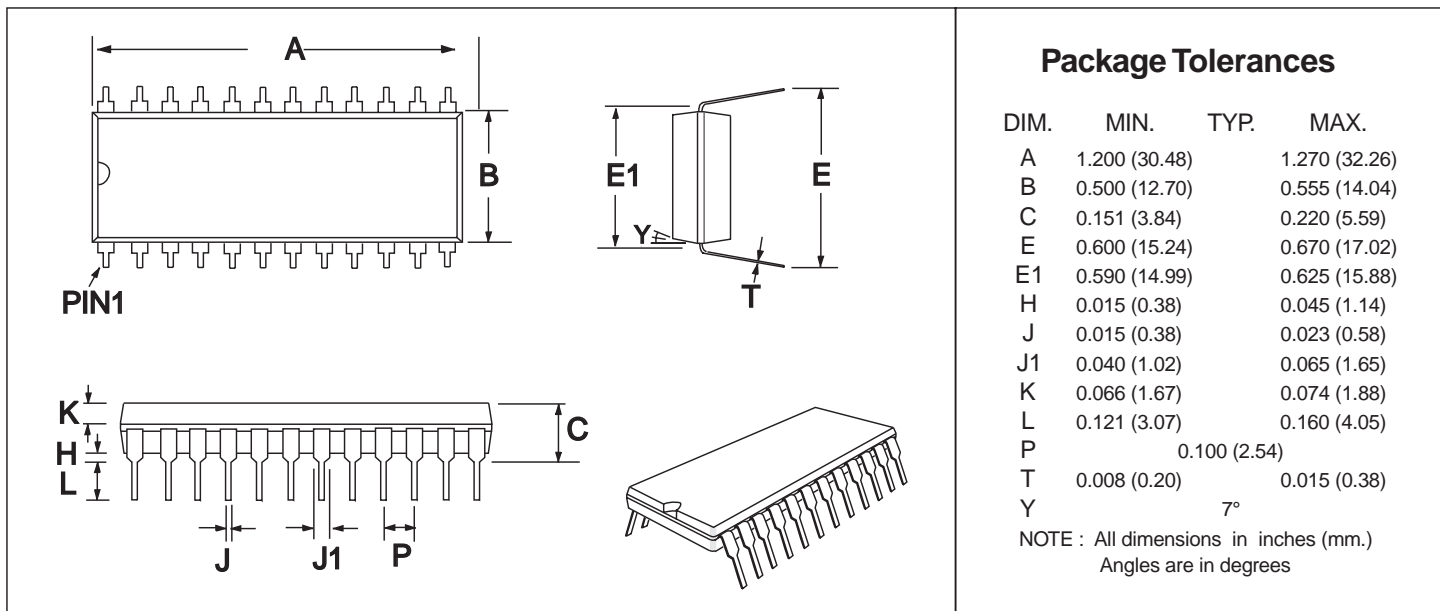


Figure 6: 24-pin PDIP Mechanical Outline: Order as part no. MX014P

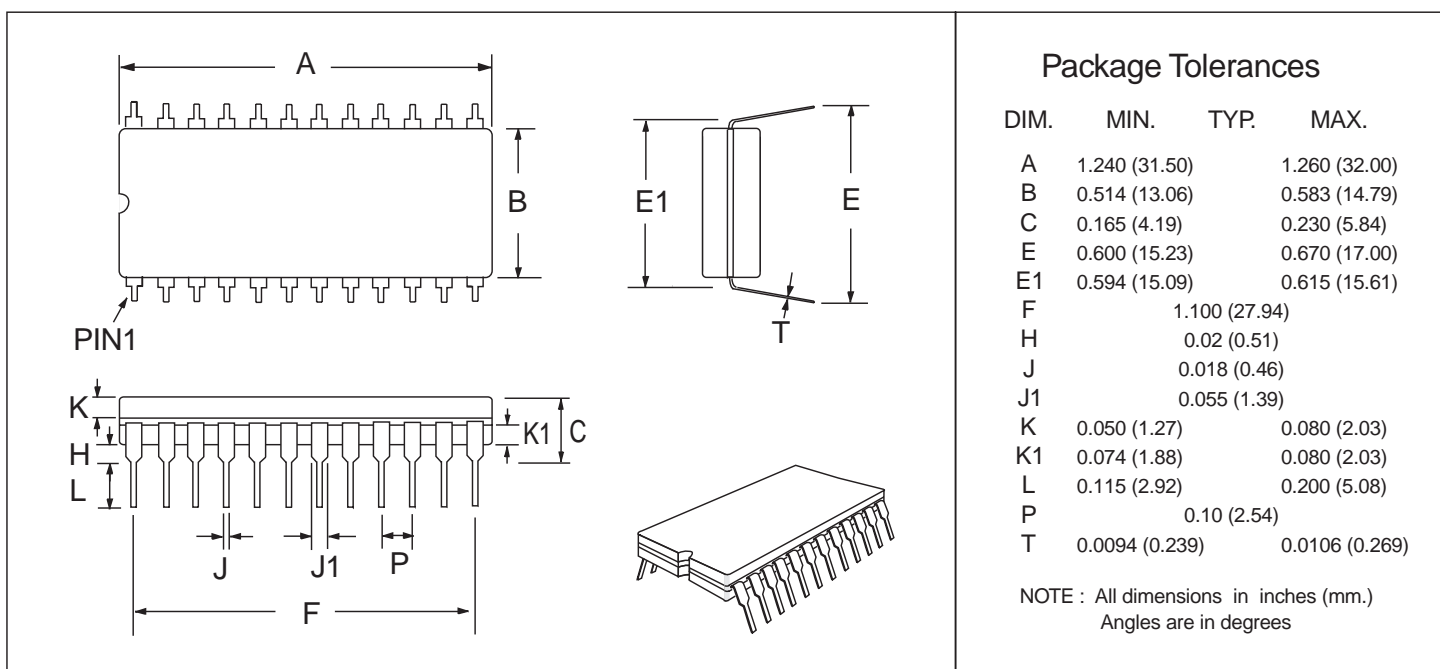


Figure 7: 24-pin CDIP Mechanical Outline: Order as part no. MX014J