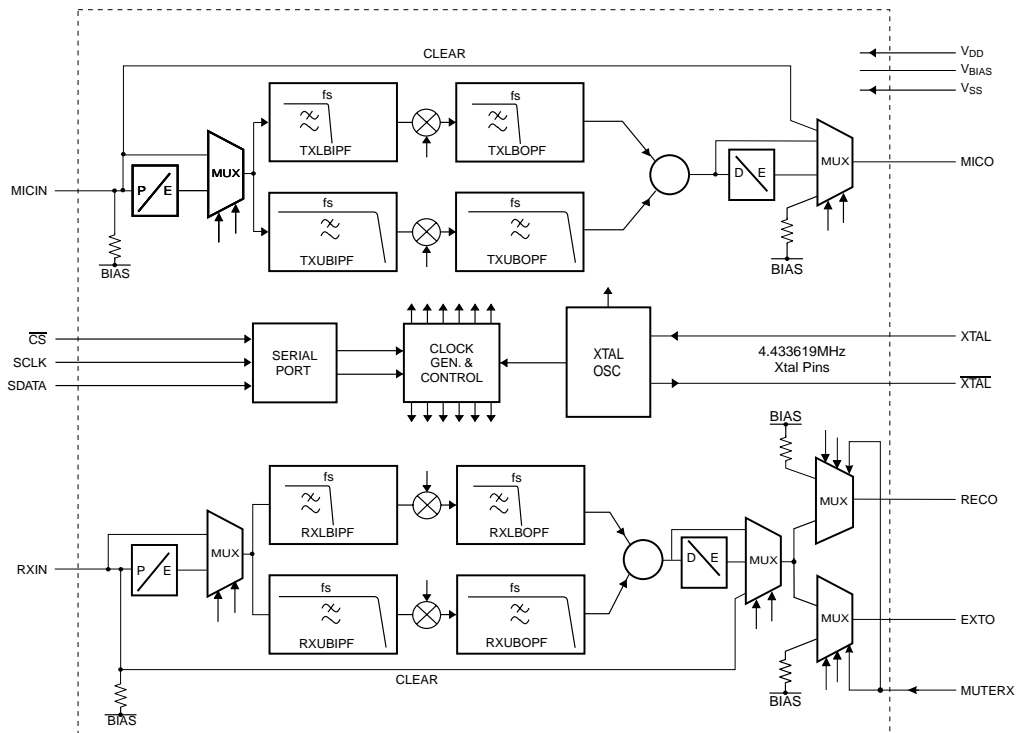


**Features and Applications**

- Ensures Privacy
- Full Duplex Operation
- High Quality Recovered Audio
- Low Height, Surface Mount Package
- 3.0V, Low Power Operation
- Fixed or Rolling Code
- Standby Mode
- Uses Split Band Inversion
- Low Current, Low Voltage
- 4.433619MHz Operation



The CMX264 is a frequency domain scrambler for use in analog cellular phone systems. It contains separate Tx and Rx paths for full duplex operation and operates under  $\mu$ Processor control via a simple serial interface.

In the Tx path, scrambling is achieved by splitting the audio band into two parts, or sub-bands, and frequency inverting each one. The frequency at which the signal is split, the "split-point", can be either fixed or rolling between four possible settings resulting in a transmitted audio signal which is unintelligible to eavesdroppers.

Descrambling is achieved by a receive device set to the same split point as the remote transmitter. Thus if the Tx and Rx devices are synchronously cycled through the same sequence of split points, a clear recovered signal will emerge at the output of the receiver.

A 4.433619MHz crystal is used allowing up to four split points to be programmed. The device is designed to be compatible with existing cell-phone circuitry.

The CMX264 operates at 3.0V and is available in a 24-pin SSOP (CMX264D5).

# CONTENTS

| Section  | Page      |
|--|-----------|
| <b>1 Block Diagram</b> .....                               | <b>4</b>  |
| <b>2 Signal List</b> .....                                 | <b>5</b>  |
| <b>3 External Components</b> .....                         | <b>6</b>  |
| <b>4 General Description</b> .....                         | <b>7</b>  |
| 4.1 Tx Channel .....                                       | 7         |
| 4.1.1 Tx Channel Pre-Emphasis .....                        | 7         |
| 4.1.2 Tx Lowerband Input Filter (TXLBIPF).....             | 7         |
| 4.1.3 Tx Lowerband Balanced Modulator.....                 | 7         |
| 4.1.4 Tx Lowerband Output Filter (TXLBOPF).....            | 7         |
| 4.1.5 Tx Upperband Input Filter (TXUBIPF).....             | 7         |
| 4.1.6 Upperband Balanced Modulator.....                    | 7         |
| 4.1.7 Tx Upperband Output Filter (TXUBOPF) .....           | 8         |
| 4.1.8 Tx Summer .....                                      | 8         |
| 4.1.9 Tx Channel De-Emphasis .....                         | 8         |
| 4.2 Rx Channel.....  | 8         |
| 4.2.1 Rx Channel Pre-Emphasis .....                        | 8         |
| 4.2.2 Rx Lowerband Input Filter (RXLBIPF).....             | 8         |
| 4.2.3 Rx Lowerband Balanced Modulator .....                | 8         |
| 4.2.4 Rx Lowerband Output Filter (RXLBOPF) .....           | 8         |
| 4.2.5 Rx Upperband Input Filter (RXUBIPF) .....            | 8         |
| 4.2.6 Rx Upperband Balanced Modulator .....                | 8         |
| 4.2.7 Rx Upperband Output Filter (RXUBOPF).....            | 9         |
| 4.2.8 Rx Summer .....                                      | 9         |
| 4.2.9 Rx Channel De-Emphasis .....                         | 9         |
| 4.3 Serial Interface .....                                 | 9         |
| 4.3.1 General Operation.....                               | 9         |
| 4.3.2 Powersave Mode (D10).....                            | 9         |
| 4.3.3 Clear/Scramble Modes (D9).....                       | 9         |
| 4.3.4 Output Select (D8, D7, D6) .....                     | 10        |
| 4.3.5 Pre/De-Emphasis Select (D5, D4, D3, D2) .....        | 11        |
| 4.3.6 Scramble Mode - Split Point Selection (D1, D0) ..... | 11        |
| <b>5 Application Notes</b> .....                           | <b>11</b> |
| 5.1 General Use .....                                      | 11        |
| 5.2 Input Anti-Alias and Output Smoothing Filters.....     | 12        |
| 5.2.1 Input Anti-Alias Filtering .....                     | 12        |
| 5.2.2 Output Smoothing .....                               | 12        |

|          |                                       |           |
|----------|---------------------------------------|-----------|
| <b>6</b> | <b>Performance Specification.....</b> | <b>12</b> |
| 6.1      | Electrical Performance .....          | 12        |
| 6.1.1    | Absolute Maximum Ratings.....         | 12        |
| 6.1.2    | Operating Limits .....                | 12        |
| 6.1.3    | Operating Characteristics.....        | 13        |
| 6.2      | Packaging.....                        | 22        |

|  |
|--|
| MX-COM, Inc. reserves the right to change specifications at any time and without notice. |
|--|

# 1 Block Diagram

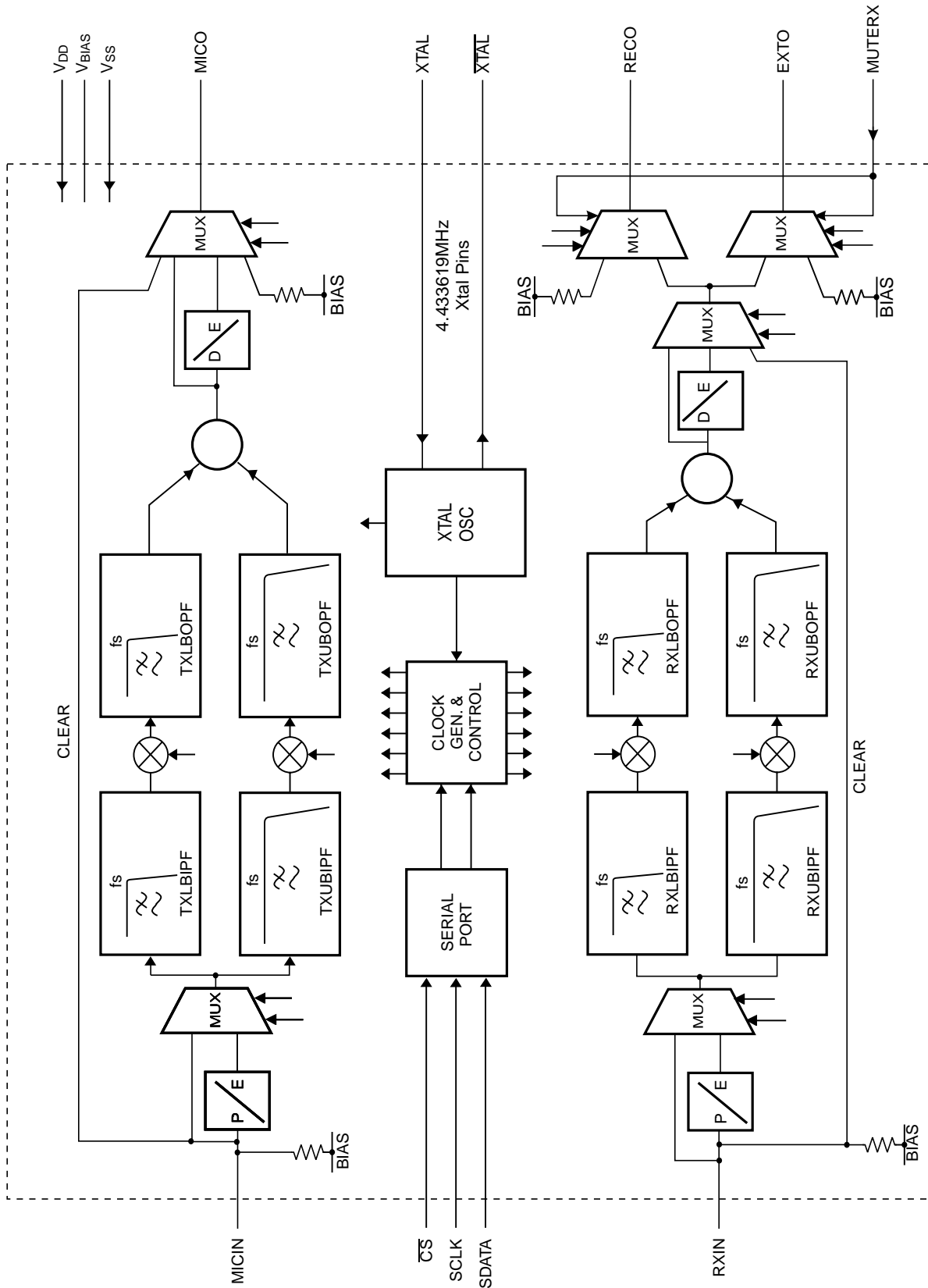


Figure 1: Block Diagram

## 2 Signal List

| Packages<br>Pin No. | Signal                   |        | Description   |
|---------------------|--------------------------|--------|---|
|                     | Name                     | Type   |   |
| 1                   | N/C                      |        | This pin should be left unconnected.  |
| 2                   | N/C                      |        | This pin should be left unconnected.  |
| 3                   | XTAL                     | input  | A 4.433619MHz crystal is connected to these pins with the appropriate external components (see Figure 2).   |
| 4                   | $\overline{\text{XTAL}}$ | output | Alternatively, an externally derived clock signal may be applied to the XTAL pin. In this case, the $\overline{\text{XTAL}}$ pin should be left unconnected.  |
| 5                   | N/C                      |        | This pin should be left unconnected.  |
| 6                   | MICO                     | output | The Tx audio output from the scrambler. This signal may be scrambled or clear. If scrambled it may come from the variable split-band (VSB) scrambler direct or via the Tx de-emphasis block. All signal paths depend upon the internal state selected.  |
| 7                   | N/C                      |        | This pin should be left unconnected.  |
| 8                   | V <sub>BIAS</sub>        | output | A bias line for the internal circuitry, internally held at V <sub>DD</sub> /2. This pin must be decoupled to V <sub>SS</sub> by a capacitor mounted close to the device pins.   |
| 9                   | N/C                      |        | This pin should be left unconnected.  |
| 10                  | N/C                      |        | This pin should be left unconnected.  |
| 11                  | MICIN                    | input  | The input for the signal from the microphone amplifier/limiter. This pin may be the input to the Tx pre-emphasis circuit, the VSB scrambler or the clear path, depending upon the internal state selected.  |
| 12                  | V <sub>SS</sub>          | power  | The negative supply rail (ground)   |
| 13                  | N/C                      |        | This pin should be left unconnected.  |
| 14                  | RXIN                     | input  | The input for the received audio signal, whether scrambled or clear. This pin may be routed to the Rx pre-emphasis circuit, the flatband frequency descrambler or the clear path, according to the internal state selected via the serial interface.  |
| 15                  | N/C                      |        | This pin should be left unconnected.  |
| 16                  | MUTERX                   | input  | A logic input which when high (V <sub>DD</sub> ) immediately de-activates the two Rx outputs (RECO and EXT0), overriding the serial data previously loaded. When this input is low (V <sub>SS</sub> ), the Rx outputs are controlled by the serial data port.   |
| 17                  | EXT0                     | output | One of two Rx outputs. This is used for routing the recovered audio to external devices, e.g. a speakerphone. This output may be independently activated or de-activated by selecting the appropriate internal state. When de-activated, either by the serial data or by the MUTERX pin, the output is set to V <sub>BIAS</sub> . |
| 18                  | N/C                      |        | This pin should be left unconnected.  |
| 19                  | RECO                     | output | The other Rx output. This is used for routing the recovered audio to the telephone loudspeaker. This output may be independently activated or de-activated by selecting the appropriate internal state. When de-activated, either by the serial data or by the MUTERX pin, the output is set to V <sub>BIAS</sub> .               |

| Packages |                 | Signal |  | Description   |
|----------|-----------------|--------|--|---|
| Pin No.  | Name            | Type   |  |   |
| 20       | NC              |        |  | This pin should be left unconnected.  |
| 21       | $\overline{CS}$ | input  |  | The serial port input pins. Data applied here sets up the internal state of the device, e.g. split point, scramble/clear, etc. See Figure 10. |
| 22       | SCLOCK          | input  |  |   |
| 23       | SDATA           | input  |  |   |
| 24       | $V_{DD}$        | power  |  | The positive supply rail. This pin must be decoupled to $V_{SS}$ by a capacitor mounted close to the device.                                  |

Table 1: Signal List

### 3 External Components

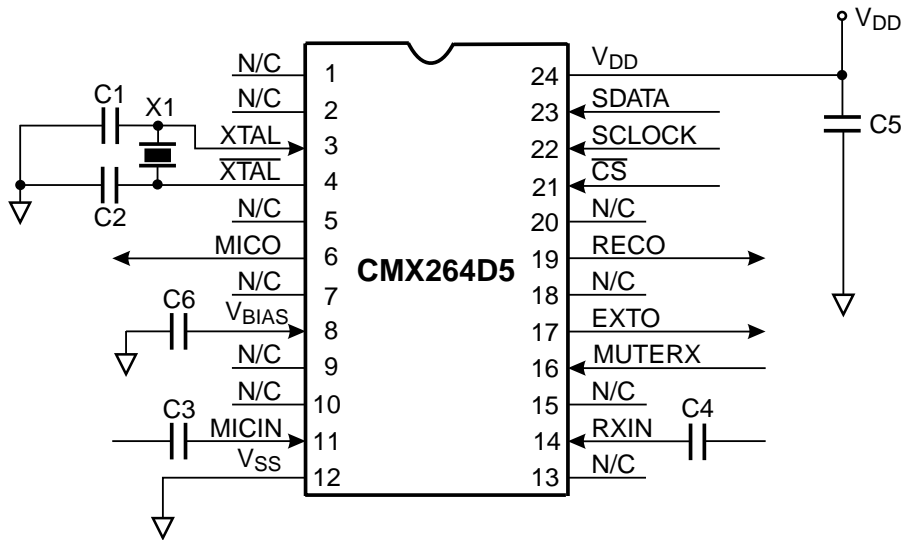


Figure 2: Recommended External Components

|    |             |      |
|----|-------------|------|
| C1 | 10pF        | ±10% |
| C2 | 10pF        | ±10% |
| C3 | 100nF       | ±20% |
| C4 | 100nF       | ±20% |
| C5 | 100nF       | ±20% |
| C6 | 100nF       | ±20% |
| X1 | 4.433619MHz |      |

Table 2: Recommended External Components

**Recommended External Components Notes:**

1. C5 and C6 should be low inductance types which are mounted close to their respective device pins.
2. For best results, a crystal oscillator design should drive the clock inverter input with signal levels of at least 40% of  $V_{DD}$ , peak to peak. Tuning fork crystals generally cannot meet this requirement. To obtain crystal oscillator design assistance, please consult your crystal manufacturer.

## 4 General Description

This device has been designed to be compatible with mobile station baseband channels. All signal processing blocks such as lowpass filters, pre-emphasis, de-emphasis, and balanced modulators use switched capacitor (SWC) techniques.

In each mode of operation, all blocks not in the signal path are turned off in order to minimize power consumption. All internal settings and signal paths are selected by means of the serial interface according to Section 1.5.3.

### 4.1 Tx Channel

#### 4.1.1 Tx Channel Pre-Emphasis

A pre-emphasis circuit at the input of the Tx scramble block. It has a slope of 6dB per octave between 280Hz and 3140Hz. In scramble mode, it may be selected to "whiten" the audio signal prior to split band inversion. It may be used in conjunction with the optional de-emphasis at the Rx output of the descrambler.

#### 4.1.2 Tx Lowerband Input Filter (TXLBIPF)

A lowpass filter whose input is the externally amplified and limited baseband audio signal from the microphone. It selects that part of the audio spectrum which is below the split point. Its output signal is processed by the lowerband balanced modulator and output filter to form the transmitted lowerband.

The bandwidth of the lowerband is controlled according to the split point chosen by varying the bandwidth of this filter. The bandwidth is proportional to the sampling clock frequency and so an appropriate clock frequency is internally selected for each split point.

#### 4.1.3 Tx Lowerband Balanced Modulator

This modulates the output of the Tx Lowerband Input Filter (TXLBIPF) to form a frequency shifted upper sideband and a frequency inverted lower sideband. It is the frequency inverted lower sideband which is eventually transmitted as the lower frequency part of the scrambled signal, i.e. the lowerband.

The lower carrier frequency varies with split point and is always about 230Hz above the corner frequency of the preceding lowpass filter (TXLBIPF). This means that baseband frequencies around 230Hz below the lower carrier frequency are translated to approximately 230Hz in the scrambled audio. These frequencies form the lowest corner frequency of the transmit spectrum.

#### 4.1.4 Tx Lowerband Output Filter (TXLBOPF)

A lowpass filter whose input is the output signal from the lowerband balanced modulator. Its function is to select the frequency inverted lower sideband and remove the upper sideband. The resulting output signal from this filter forms the lowerband part of the scrambled audio. It is summed with the output of the Tx upperband channel to form the complete scrambled signal for transmission. This filter's corner response also eventually defines the lower corner frequency of the recovered audio.

#### 4.1.5 Tx Upperband Input Filter (TXUBIPF)

A lowpass filter whose cutoff frequency represents the upper limit of the baseband audio which is scrambled, transmitted and descrambled. The output from this filter is processed by the upperband balanced modulator, the output filter and any external channel filtering to form the transmitted upperband.

#### 4.1.6 Upperband Balanced Modulator

This modulates the output of the Tx Upperband Input Filter (TXUBIPF) to form two sidebands, a frequency inverted lower sideband and a non-inverted upper sideband. Part of the inverted lower sideband is selected by the Tx Upperband Output Filter (TXUPOPF) to form the transmitted upperband, i.e. that part of the audio spectrum above the split point.

For each split point setting, the upper carrier frequency is chosen so that baseband frequencies close to 2770Hz are shifted to just above the split point. Conversely, baseband frequencies just above the split point are shifted to the upper transmission limit of the channel. The result is that the upper carrier is the same (approximate) distance above the lower carrier at all split point settings. The approximation arises because of the need to have frequencies derivable from the crystal frequency and the fact that only certain divisors of associated filter sample rates have been chosen as carriers, in order to avoid aliasing.

#### 4.1.7 Tx Upperband Output Filter (TXUBOPF)

A lowpass filter whose input is the output signal from the upperband balanced modulator. Its function is to select that part of the frequency inverted lower sideband which will form the upperband part of the transmitted scrambled audio. This output is summed with the output of the lowerband Tx channel to form the complete scrambled signal for transmission.

This filter's response, together with any external filtering e.g. a lowpass filter used to ensure compliance with statutory transmission requirements, defines the upper frequency of the transmitted scrambled signal.

#### 4.1.8 Tx Summer

This sums the lowerband and upperband to form the complete scrambled audio signal prior to transmission.

#### 4.1.9 Tx Channel De-Emphasis

A de-emphasis circuit at the output of the Tx scramble block. It has a slope of -6dB per octave between 280Hz and 3140Hz. It may be used to compensate for pre-emphasis in the transmission channel.

### 4.2 Rx Channel

#### 4.2.1 Rx Channel Pre-Emphasis

A pre-emphasis circuit at the input of the Rx descramble block. It has a slope of 6dB per octave between 280Hz and 3140Hz. In descramble mode, it may be selected to pre-emphasize the received audio signal prior to signal recovery. It may, for example, be used to compensate for de-emphasis in the transmission channel.

#### 4.2.2 Rx Lowerband Input Filter (RXLBIPF)

A lowpass filter whose function is to select the lowerband part of the received scrambled signal. Its bandwidth is controlled by the split point setting, which should be chosen to match the spectrum of the received lowerband.

#### 4.2.3 Rx Lowerband Balanced Modulator

This modulates the output of the preceding Rx Lowerband Input Filter (RXLBIPF). The carrier is identical to that of the lowerband carrier in the transmitter section. The output consists of two sidebands.

The lower sideband is inverted with respect to the received lowerband, i.e. returned to its original frequency with respect to the original baseband signal. If the Tx and Rx carriers are the same frequency, the lower sideband is the desired recovered lowerband.

The upper sideband is not required in the final descrambled output. It is removed by the Rx Lowerband Output Filter (RXLBOPF)

#### 4.2.4 Rx Lowerband Output Filter (RXLBOPF)

A lowpass filter whose function is to select the lower sideband output of the preceding balanced modulator. Its output is the lowerband part of the descrambled signal which is summed with the output of the upperband Rx channel to form the complete descrambled signal.

#### 4.2.5 Rx Upperband Input Filter (RXUBIPF)

A lowpass filter whose cutoff frequency is close to the upper corner frequency of the transmit channel. Its function is to select the received scrambled signal and reject channel noise at frequencies above this signal.

It is assumed that any transmitted 4kHz SAT tone has been attenuated prior to the Rx channel input of the CMX264.

#### 4.2.6 Rx Upperband Balanced Modulator

This modulates the output of the preceding Rx Upperband Input Filter (RXUBIPF). The carrier is identical to that of the upperband carrier in the transmitter section. The output consists of two sidebands.

The lower sideband is inverted with respect to the received lowerband, i.e. non-inverted with respect to the original baseband signal. If the Tx and Rx carriers are the same frequency, the lower sideband is the desired recovered upperband.

The upper sideband is a non-inverted, frequency shifted signal and is not required in the final descrambled output. It is removed by the Rx Upperband Output Filter (RXUBOPF).



### 4.2.7 Rx Upperband Output Filter (RXUBOPF)

A lowpass filter whose function is to select the lower sideband output of the Rx upperband balanced modulator. Its output is the upperband part of the descrambled signal which is summed with the output of the lowerband Rx channel to form the complete descrambled signal.

### 4.2.8 Rx Summer

This sums the lowerband and upperband to form the complete descrambled audio signal.

### 4.2.9 Rx Channel De-Emphasis

A de-emphasis circuit at the output of the Rx descramble block. It has a slope of -6dB per octave between 280Hz and 3140Hz. It may be selected to de-emphasise the recovered (descrambled) audio signal. It may be selected in conjunction with the pre-emphasis circuit at the input of the Tx scramble block.

## 4.3 Serial Interface

### 4.3.1 General Operation

The serial interface controls the internal states and modes of operation of the CMX264. Data is input to the SDATA pin MSD (D10) first and is clocked into the device on the rising edge of SCLK. Only the last 11 bits of data is loaded on the rising edge of CS. The bit functions are shown in Table 3. Also refer to the timing diagram of Figure 10.

| D10       | D9             | D8                  | D7                  | D6                  | D5                            | D4 | D3 | D2                 | D1 | D0 |
|-----------|----------------|---------------------|---------------------|---------------------|-------------------------------|----|----|--------------------|----|----|
| Powersave | Clear/Scramble | MICO Output Control | RECO Output Control | EXTO Output Control | Pre/De-Emphasis Select/Bypass |    |    | Split Point Select |    |    |

Table 3: General Operation

### 4.3.2 Powersave Mode (D10)

| D10 | D9 | D8 | D7 | D6 | D5 | D4 | D3 | D2 | D1 | D0 |
|-----|----|----|----|----|----|----|----|----|----|----|
| 1   | X  | X  | X  | X  | X  | X  | X  | X  | X  | X  |

Table 4: Powersave Mode

D10 = 1 powersaves the whole device, including the oscillator. All other bits become DON'T CARE when this mode is selected.

On power up, the CMX264 automatically sets itself into the powersave state.

The host equipment should then select the operating mode via the serial interface at least 3ms after initial power up. The delay is to allow the reset circuit to become dormant. This is the only occasion on which it operates.

### 4.3.3 Clear/Scramble Modes (D9)

| D10 | D9 | D8                  | D7                  | D6                  | D5 | D4 | D3 | D2 | D1 | D0 |
|-----|----|---------------------|---------------------|---------------------|----|----|----|----|----|----|
| 0   | 1  | MICO Output Control | RECO Output Control | EXTO Output Control | X  | X  | X  | X  | X  | X  |

Table 5: Clear Mode

D9 = 1 selects **clear** mode. The scramble, descramble, pre-emphasis and de-emphasis blocks in both Tx and Rx channels are all bypassed. No signal processing or filtering is carried out.

All other bits become DON'T CARE except the output select bits (D8, D7, D6).

| D10 | D9 | D8                  | D7                  | D6                  | D5                           | D4 | D3 | D2                 | D1 | D0 |
|-----|----|---------------------|---------------------|---------------------|------------------------------|----|----|--------------------|----|----|
| 0   | 0  | MICO Output Control | RECO Output Control | EXTO Output Control | Pre/De-Emphasis Block Select |    |    | Split Point Select |    |    |

Table 6: Scramble Mode

D9 = 0 selects **scramble** mode, i.e. the scrambler and descrambler blocks in the Tx and Rx channels are selected.

In this mode, the split point is controlled by bits D1, D0. The four Pre-De-Emphasis blocks are independently selectable by means of bits D5, D4, D3, D2.

#### 4.3.4 Output Select (D8, D7, D6)

| D10 | D9 | D8 | D7 | D6 | D5              | D4                    | D3     | D2     | D1                    | D0                    | MICO   | RECO   | EXTO   |        |        |        |
|-----|----|----|----|----|-----------------|-----------------------|--------|--------|-----------------------|-----------------------|--------|--------|--------|--------|--------|--------|
| 0   | 0  | 0  | 0  | 0  | Pre/De-Emphasis |                       |        |        | Split Point<br>Select |                       | Bias   | Bias   | Bias   |        |        |        |
|     |    | 0  | 0  | 1  | Select/Bypass   |                       |        |        |                       |                       |        | Active | Active |        |        |        |
|     |    | 0  | 1  | 0  |                 |                       |        |        |                       |                       |        | Active | Bias   | Bias   |        |        |
|     |    | 0  | 1  | 1  |                 |                       |        |        |                       |                       |        |        | Active | Active |        |        |
|     |    | 1  | 0  | 0  |                 |                       |        |        |                       |                       | Active | Bias   | Bias   |        |        |        |
|     |    | 1  | 0  | 1  |                 |                       |        |        |                       |                       |        | Active | Active |        |        |        |
|     |    | 1  | 1  | 0  |                 |                       |        |        |                       |                       |        | Active | Bias   | Bias   |        |        |
|     |    | 1  | 1  | 1  |                 |                       |        |        |                       |                       |        |        | Active | Active |        |        |
|     | 1  | 1  | 0  | 0  | 0               | Pre/De-Emphasis       |        |        |                       | Scrambler<br>Bypassed |        | Bias   | Bias   | Bias   |        |        |
|     |    |    | 0  | 0  | 1               | Blocks all Powersaved |        |        |                       |                       |        |        | Active | Active |        |        |
|     |    |    | 0  | 1  | 0               | and Bypassed          |        |        |                       |                       |        |        | Active | Bias   | Bias   |        |
|     |    |    | 0  | 1  | 1               | X                     | X      | X      | X                     |                       |        | X      |        | X      | Active | Active |
|     |    |    | 1  | 0  | 0               |                       |        |        |                       |                       |        | Active |        | Bias   | Bias   |        |
|     |    |    | 1  | 0  | 1               |                       |        |        |                       |                       |        |        | Active | Active |        |        |
| 1   | 1  | 0  |    |    |                 |                       | Active | Bias   | Bias                  |                       |        |        |        |        |        |        |
| 1   | 1  | 1  |    |    |                 |                       |        | Active | Active                |                       |        |        |        |        |        |        |

Table 7: Output Select

Bits D8, D7, D6 activate or de-activate the audio outputs in both **clear** (D9 = 1) and **scramble** (D9 = 0) modes:

Bit D8 controls the Tx output MICO.

Bit D7 controls the Rx output RECO.

Bit D6 controls the Rx output EXTO.

In all cases, the output is activated by setting the relevant data bit to logic 1 and is de-activated by setting the bit to logic 0. The Rx outputs (RECO and EXTO) can also be de-activated by the MUTERX pin, which asynchronously overrides bits D6 and D7.

When activated, the signal output at an output pin is determined by the internal state of the device, e.g. in **clear** mode (D9 = 1), the MICO pin will output the signal from the MICIN pin. In **scramble** mode, when the Tx de-emphasis circuit is selected, the MICO pin will carry the signal from the de-emphasis output, and so on.

When de-activated, an output is pulled to  $V_{BIAS}$  by means of an internal high impedance.

#### 4.3.5 Pre/De-Emphasis Select (D5, D4, D3, D2)

| D10 | D9 | D8                     | D7                     | D6                     | D5   | D4 | D3 | D2 | D1                    | D0 |
|-----|----|------------------------|------------------------|------------------------|--|----|----|----|-----------------------|----|
| 0   | 0  | MICO<br>Output Control | RECO<br>Output Control | EXTO<br>Output Control | Pre/De-Emphasis<br>Select/Bypass<br>(See Text) |    |    |    | Split Point<br>Select |    |

**Table 8: Pre/De-Emphasis Select**

Bits D5, D4, D3, D2 have an effect in **scramble** mode only and are used to select or bypass the pre-emphasis and de-emphasis blocks.

The bits are used as follows:

|    |            |                    |
|----|------------|--------------------|
| D2 | Tx Channel | Input Pre-Emphasis |
| D3 | Tx Channel | Output De-Emphasis |
| D4 | Rx Channel | Input Pre-Emphasis |
| D5 | Rx Channel | Output De-Emphasis |

In all cases, setting the relevant bit to 1 selects the block. Resetting the bit to 0 bypasses and powersaves it.

#### 4.3.6 Scramble Mode - Split Point Selection (D1, D0)

| D10 | D9 | D8                        | D7                        | D6                        | D5                               | D4 | D3 | D2 | D1 | D0 | Split Point<br>(Hz) | Lower Carrier<br>(Hz) | Upper Carrier<br>(Hz) |
|-----|----|---------------------------|---------------------------|---------------------------|----------------------------------|----|----|----|----|----|---------------------|-----------------------|-----------------------|
| 0   | 0  | MICO<br>Output<br>Control | RECO<br>Output<br>Control | EXTO<br>Output<br>Control | Pre/De-Emphasis<br>Select/Bypass |    |    |    | 0  | 0  | 1966                | 2244                  | 5132                  |
|     |    |                           |                           |                           |                                  |    |    |    | 0  | 1  | 1482                | 1759                  | 4618                  |
|     |    |                           |                           |                           |                                  |    |    |    | 1  | 0  | 1276                | 1551                  | 4398                  |
|     |    |                           |                           |                           |                                  |    |    |    | 1  | 1  | 1027                | 1304                  | 4198                  |

**Table 9: Scramble Mode - Split Point Selection**

Bits D1, D0 operate in **scramble** mode only and are used to select the split point.

## 5 Application Notes

### 5.1 General Use

The transmit scramble function may be implemented by connecting the device in the microphone line. The receive function is achieved by connecting the device in the earpiece line. Some external pre- and post-amplification and limiting may be necessary to ensure good signal to noise and dynamic range performance.

Many existing cellphones incorporate the functions of SAT tone filtering and anti-splatter filtering so these features are not included in the CMX264. The transmit and receive spectral shaping is designed to make this interfacing easy.

It is anticipated that statutory transmission requirements will be met by filtering within the host equipment e.g. for removal of a SAT tone at 4kHz. The filtering required for this is quite stringent (see Figure 8) and so the Tx Upperband Output Filter (TXUBOPF) has been designed to avoid unnecessary signal loss in the region of 3kHz. (see Figure 7).

Because this filter does not completely remove unwanted harmonics from the output of the upperband balanced modulator, transmit output distortion and noise is specified at the output of the host transmit filter (see Section 6.1.3).

It is desirable to introduce any channel control signals (whether in-band or sub-audio) after the scramble function and to remove the signals before descrambling.

## 5.2 Input Anti-Alias and Output Smoothing Filters

### 5.2.1 Input Anti-Alias Filtering

The internal circuitry of the device uses sampled techniques and so anti-alias filtering and post-filtering (smoothing) may be required.

Input anti-alias filtering is supplied on chip at the MICIN and RXIN inputs. The filtering is first order with a corner frequency of 25kHz.

Possible alias frequencies are:

|   |            |                                |
|---|------------|--------------------------------|
| <b>With input pre-emphasis selected</b>     | 63.337kHz  |                                |
| <b>With input pre-emphasis not selected</b> | 85.261kHz  | (Split point 1)                |
|   | 63.337kHz  | (Split point 2 and clear mode) |
|   | 52.780kHz  | (Split point 3)                |
|   | 44.336kHz  | (Split point 4)                |
|   | 184.734kHz | (All split points)             |

### 5.2.2 Output Smoothing

All output buffers are sampled circuits clocked at 63.337kHz but no post-filtering is provided on chip. This is not included in this product as such circuitry is normally included elsewhere, so it may be necessary for the host equipment to provide this filtering either to comply with transmission requirements or to prevent aliasing within other sampled circuits in the system.

## 6 Performance Specification

### 6.1 Electrical Performance

#### 6.1.1 Absolute Maximum Ratings

Exceeding these maximum ratings can result in damage to the device.

|   | Min. | Max.           | Units   |
|---|------|----------------|---|
| Supply ( $V_{DD} - V_{SS}$ )  | -0.3 | 7.0            | V   |
| Voltage on any pin to $V_{SS}$                                      | -0.3 | $V_{DD} + 0.3$ | V   |
| Current into or out of $V_{DD}$ and $V_{SS}$ pins                   | -30  | +30            | mA  |
| Current into or out of any other pin                                | -20  | +20            | mA  |
| <b>D5 Package</b>   |      |                |   |
| Total Allowable Power Dissipation at $T_{AMB} = 25^{\circ}\text{C}$ |      | 550            | mW  |
| Derating above $25^{\circ}\text{C}$                                 |      | 9              | mW/ $^{\circ}\text{C}$ above $25^{\circ}\text{C}$ |
| Storage Temperature   | -55  | +125           | $^{\circ}\text{C}$                                |
| Operating Temperature   | -40  | +85            | $^{\circ}\text{C}$                                |

#### 6.1.2 Operating Limits

Correct operation of the device outside these limits is not implied.

|                              | Notes | Min.    | Max.    | Units              |
|------------------------------|-------|---------|---------|--------------------|
| Supply ( $V_{DD} - V_{SS}$ ) |       | 2.7     | 3.75    | V                  |
| Operating Temperature        |       | -40     | +85     | $^{\circ}\text{C}$ |
| Xtal Frequency               |       | 4.43229 | 4.43495 | MHz                |

### 6.1.3 Operating Characteristics

For the following conditions unless otherwise specified:

Xtal Frequency = 4.433619MHz, Noise Bandwidth = 25kHz.

$V_{DD} = 3.0V$ ,  $T_{AMB} = -40^{\circ}C$  to  $+85^{\circ}C$ .

Input Signal 0dB = 250mV (Tx Channel), 100mV (Rx Channel) @1kHz, scramble mode selected.

Neither pre nor de-emphasis enabled.

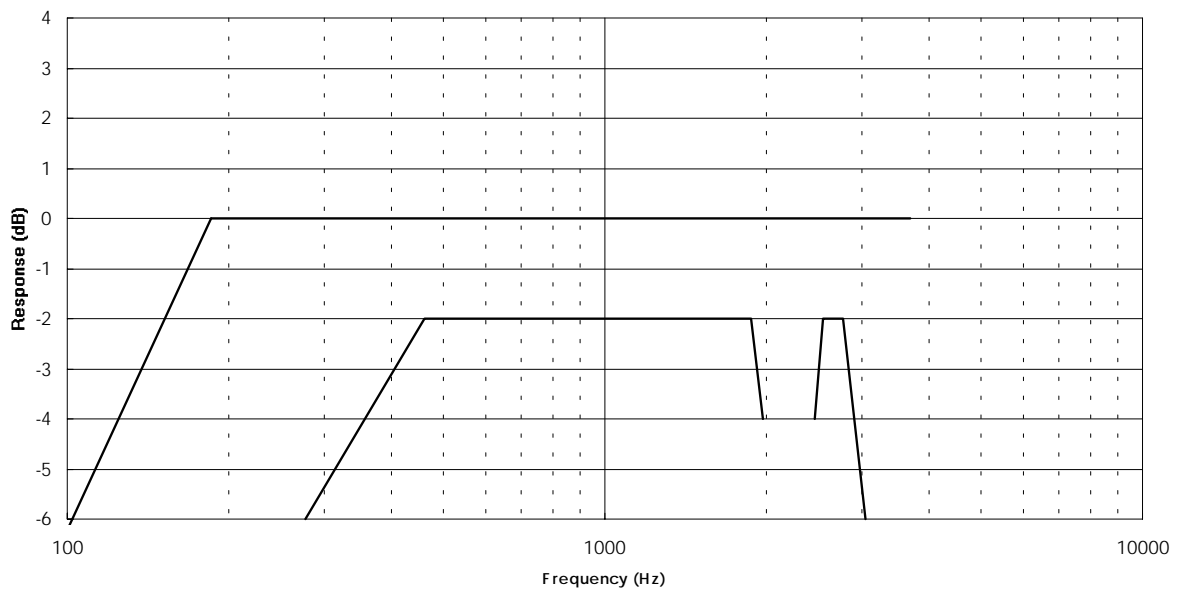
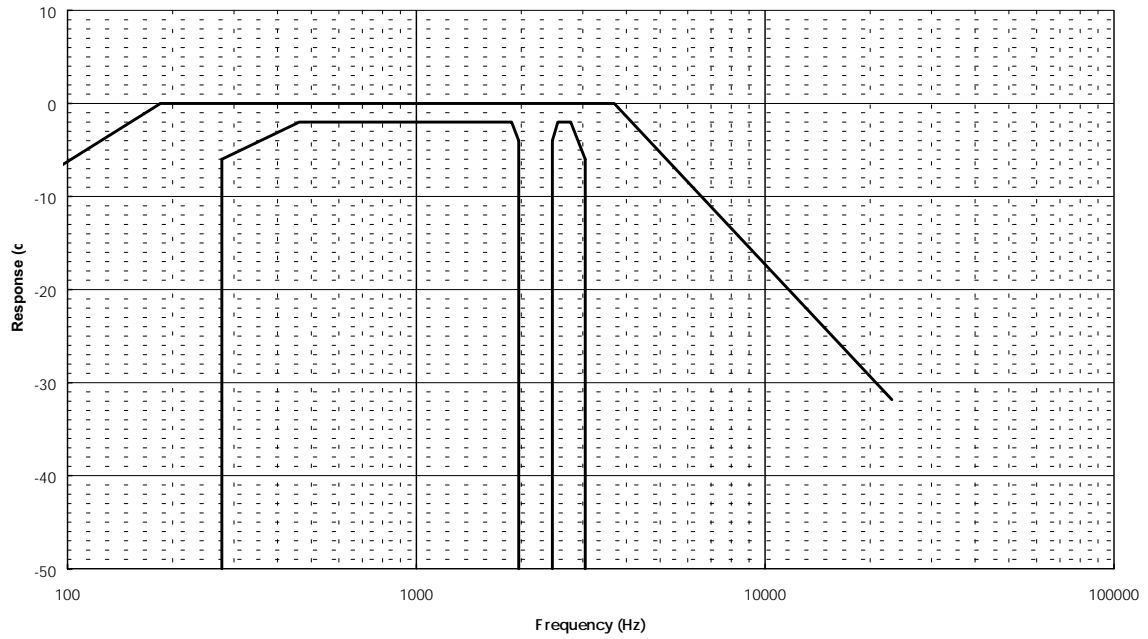
Typical radio channel filtering employed between transmitting (scrambling) and receiving (descrambling) device (such as shown in Figure 8).

|   | Notes   | Min. | Typ.  | Max.  | Units             |
|---|---------|------|-------|-------|-------------------|
| <b>DC Parameters</b>                      |         |      |       |       |                   |
| $V_{DD}$                                  |         | 2.7  |       | 3.3   | V                 |
| $I_{DD}$ (powersaved)                     | 1       |      |       | 0.3   | mA                |
| $I_{DD}$ (not powersaved)                 | 1       |      | 3.0   |       | mA                |
| <b>AC Parameters</b>                      |         |      |       |       |                   |
| <b>Tx Channel</b>                         |         |      |       |       |                   |
| Audio In (MICIN)                          |         |      |       |       |                   |
| Input Impedance                           |         | 100  |       |       | k $\Omega$        |
| Signal Level                              |         |      | 250   | 1000  | mV <sub>RMS</sub> |
| Audio Baseband Signal Lower 3dB Point     | 2       |      | 230   |       | Hz                |
| Audio Baseband Signal Upper 3dB Point     | 2       |      | 2700  |       | Hz                |
| Scrambled Audio Out (MICO)                |         |      |       |       |                   |
| Scrambled Spectrum Lower 3dB Point        | 2,3     |      | 230   |       | Hz                |
| Scrambled Spectrum Upper 3db Point        | 2,3,4   |      | 3200  |       | Hz                |
| Scrambled Spectrum Signal Level at 4000Hz | 2,3,4   |      | -26.0 |       | dB                |
| Tx Channel Passband Gain                  | 2,3,4,5 |      | -1.0  |       | dB                |
| Output Impedance (output active)          | 6       |      | 1.0   | 2.5   | k $\Omega$        |
| Output Impedance (output not active)      | 6       | 300  | 500   |       | k $\Omega$        |
| Any Spurious Output                       | 7,8,9   |      |       | -40.0 | dB                |
| Noise and Distortion                      | 7,9,10  |      |       | 2.0   | %                 |
| <b>Rx Channel</b>                         |         |      |       |       |                   |
| Scrambled Audio In (RXIN)                 |         |      |       |       |                   |
| Input Impedance                           |         | 100  |       |       | k $\Omega$        |
| Signal Level                              |         |      | 250   | 1000  | mV <sub>RMS</sub> |
| Audio Out (RECO or EXTO)                  |         |      |       |       |                   |
| Recovered Spectrum Lower 3dB Point        | 2,11    |      | 230   |       | Hz                |
| Recovered Spectrum Upper 3dB Point        | 2,11    |      | 2700  |       | Hz                |
| Rx Channel Passband Gain                  | 2,11,12 |      | -2.0  |       | dB                |
| Output Impedance (output active)          | 6       |      | 1.0   | 2.5   | k $\Omega$        |
| Output Impedance (output not active)      | 6       | 300  | 500   |       | k $\Omega$        |
| Any Spurious Output                       | 7,8     |      |       | -30.0 | dB                |
| Noise and Distortion                      | 7,10    |      |       | 4.0   | %                 |
| <b>Pre-emphasis Filters</b>               |         |      |       |       |                   |
| Slope                                     |         |      | 6.0   |       | dB/Octave         |
| Gain at 1kHz                              |         |      | 0.7   |       | dB                |

|                                       | Notes | Min. | Typ.                         | Max. | Units                |
|---------------------------------------|-------|------|------------------------------|------|----------------------|
| <b>De-emphasis Filters</b>            | 13    |      |                              |      |                      |
| Slope                                 |       |      | -6.0                         |      | dB/Octave            |
| Gain at 1kHz                          |       |      | -0.7                         |      | dB                   |
| <b>Operating Split Points</b>         | 14    |      | 1027<br>1276<br>1482<br>1966 |      | Hz<br>Hz<br>Hz<br>Hz |
| <b>Clear Mode Overall Signal Gain</b> | 15    |      | 0                            |      | dB                   |
| <b>Reset Circuit Delay</b>            | 14    |      | 3.0                          |      | Ms                   |
| <b>Serial Data Clock Frequency</b>    | 14    |      | 1.0                          |      | MHz                  |
| <b>Digital Inputs</b>                 |       |      |                              |      |                      |
| Input Logic "1" Level                 |       | 80%  |                              |      | $V_{DD}$             |
| Input Logic "0" Level                 |       |      |                              | 20%  | $V_{DD}$             |

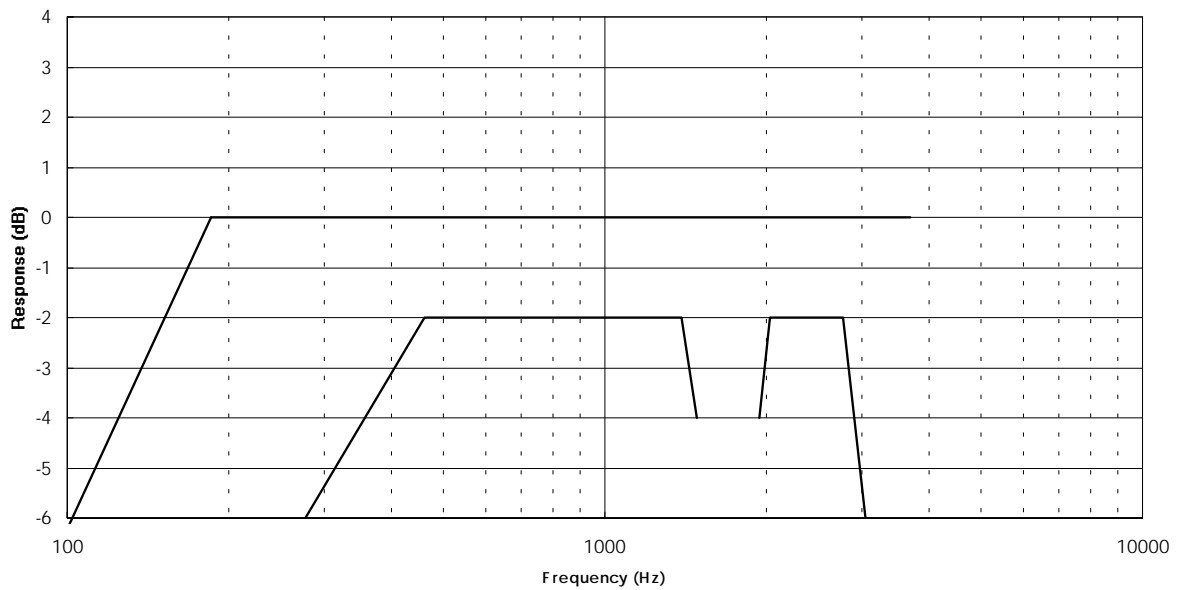
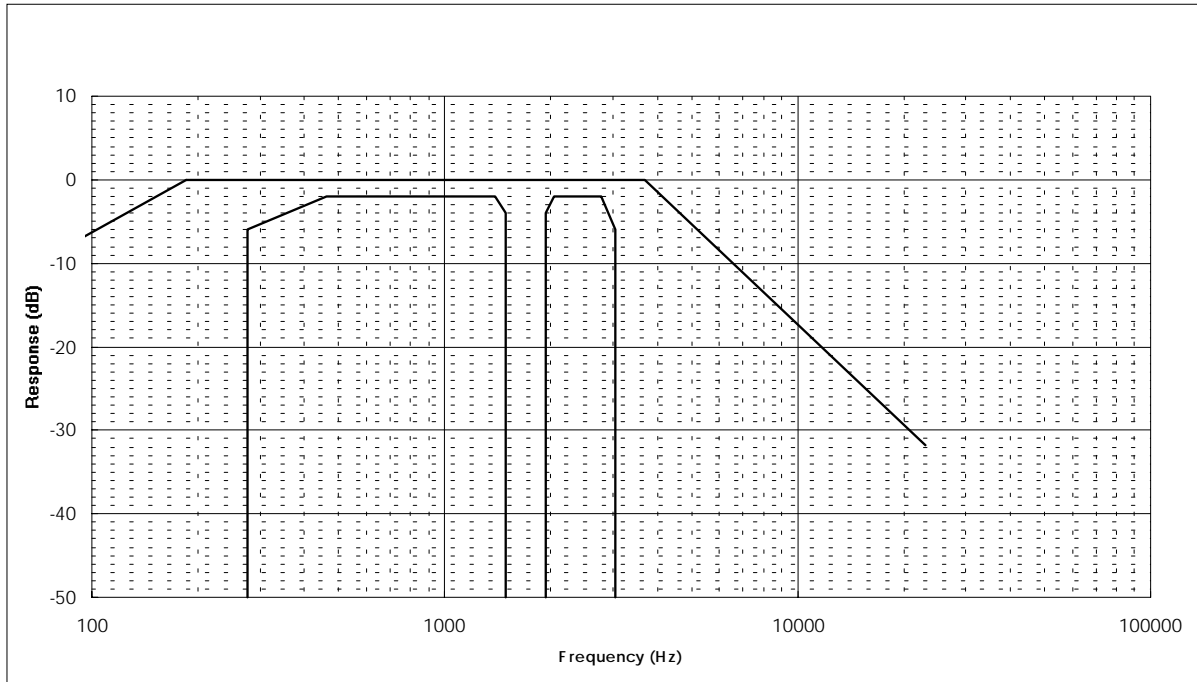
**Operating Characteristics Notes:**

1. Not including any current drawn from the device pins by external circuitry.
2. This ignores the effects of pre-emphasis and de-emphasis, if selected.
3. Relative to a single tone at the MICIN pin. Because of the frequency inversion of the scrambling process, the output frequency will not in general be equal to the input frequency. However, the scramble signal output MICO will typically be within the limits given by Figure 3, Figure 4, Figure 5, or Figure 6. The scrambled signal upper roll-off is defined by the filter TXUBOPF (Figure 7).
4. Filtering within the host equipment should ensure compliance with statutory transmission requirements e.g. removal of a 4kHz SAT tone. See Figure 8 for a typical transmit filter which would be used to accomplish this.
5. Not applicable within the region of the split point.  
In transmit, the upperband is shifted upwards away from the lowerband so that there is a gap in the scrambled spectrum. This avoids aliasing between the two bands in the recovered audio. See Figure 3, Figure 4, Figure 5, and Figure 6 which show these gaps for each split point.
6. An output may be de-activated by powersaving the whole device (D10 = 0) or by deselecting it by means of the relevant control bit (D6, D7 or D8) or, for the RECO and EXTO outputs, by setting the MUTERX pin to logic '1'
7. With a single tone at the relevant input pin (MICIN or RXIN).
8. This parameter specifies the level of any unwanted spurious tones relative to the expected output tone, whether that wanted tone is frequency shifted or not. The unwanted tones may be the result of carrier breakthrough, baseband breakthrough or other aliasing effects.
9. Measured at the output of the host transmit radio filter, such as shown in Figure 8.
10. The distortion figure of the expected output tone, whether that wanted tone is frequency shifted or not. This parameter is defined as the rms value of the spurious tones specified in Note 8 plus the noise within the measurement bandwidth, divided by the rms value of the total signal, i.e. the wanted signal plus noise plus spurious tones.
11. Specified over the complete scrambling/descrambling process i.e. scrambling by the Tx channel of the transmitting device, typical radio channel filtering such as shown in Figure 8 and descrambling by the Rx channel of the receiving device. The typical Rx channel passband gain of the CMX264 receive section only is -1.0dB.
12. Not applicable in the region of the split point.  
The response may exceed these limits within  $\pm 0.3$  octaves of the frequencies 1950Hz, 1420Hz, 1180Hz and 980Hz (for split points 1 to 4, respectively). Also, it may be outside  $\pm 3$ dB within  $\pm 0.15$  octaves of the frequencies 1900Hz, 1450Hz, 1210Hz and 1000Hz (for split points 1 to 4, respectively). In the recovered audio, some of the energy at the split point will have been transmitted in the lowerband and some will have been transmitted in the upperband. When the Rx device reconstitutes the signal, frequencies in the vicinity of the split point will consist of signals summed together which have a random phase in relation to each other. The relative phase will change over time so that the signals will vary between reinforcing each other or canceling each other, thus taking the response outside the given limits.
13. See Figure 9 for typical responses of the pre/de-emphasis circuits.
14. The internal state of the device is controlled by the data D0-D10 input at the serial interface. Data should not be loaded until 3ms after initial power up to allow the reset circuit to complete its operation and exit the RESET state.
15. No filtering is performed in clear mode, however there is a possibility of aliasing at 63.337kHz (see Section 5.2.1).

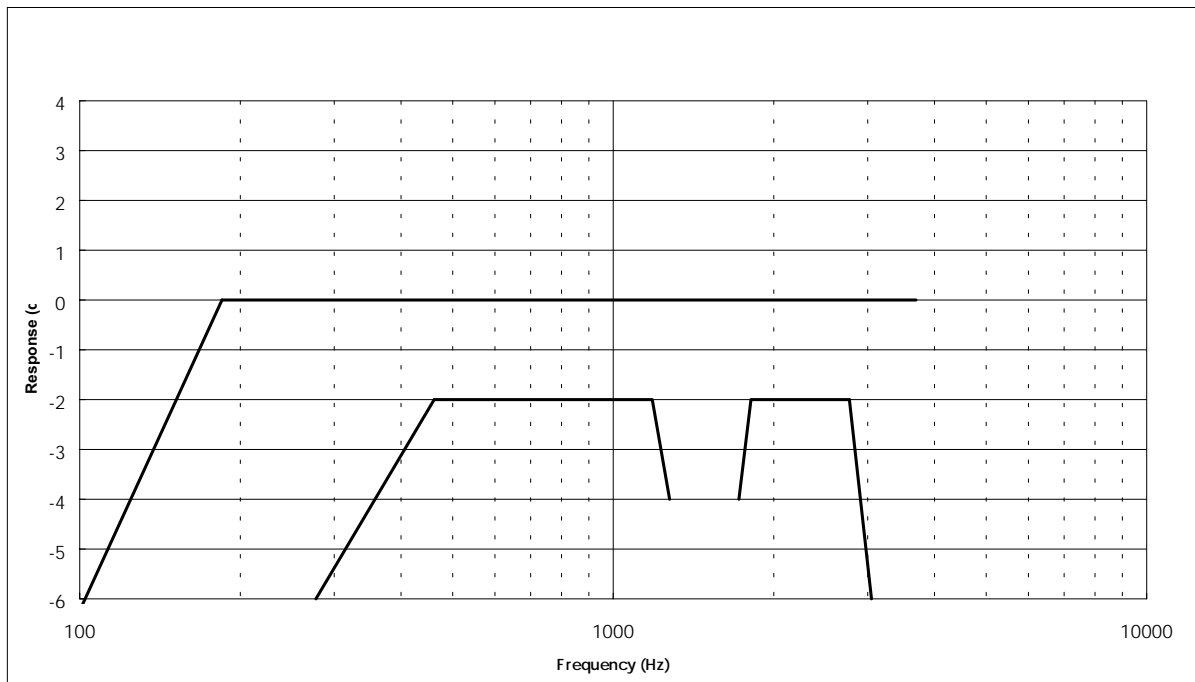
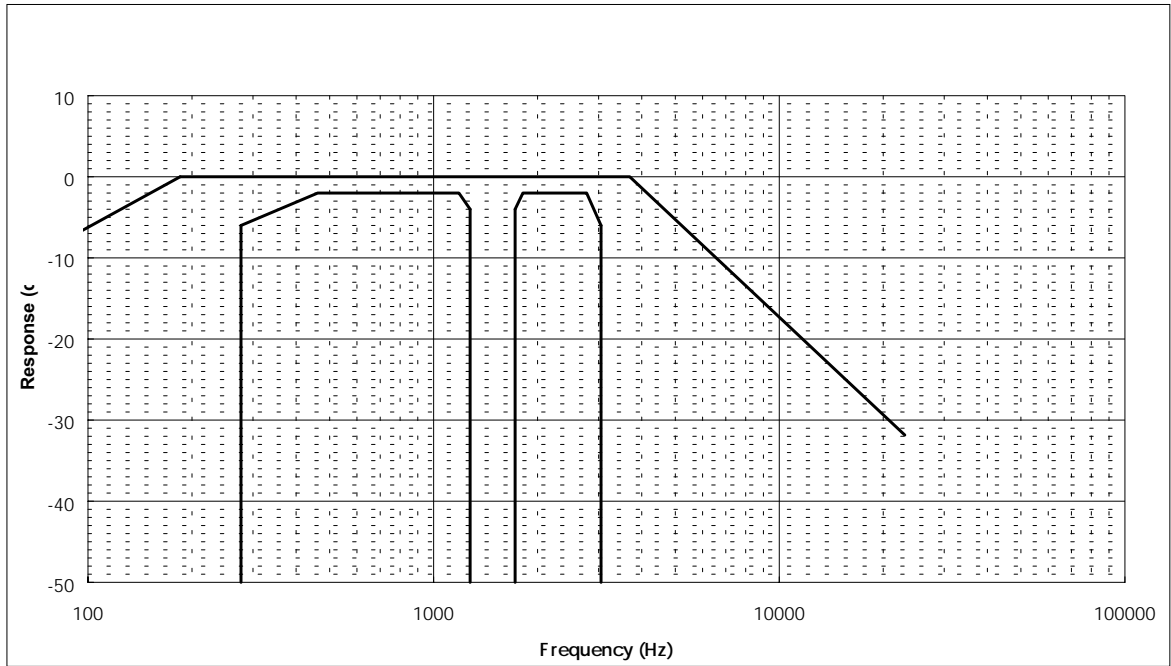


**Figure 3: Typical Response Envelope of Scramble Signal at MICO pin, relative to MICIN, with Split Point 1 Selected**

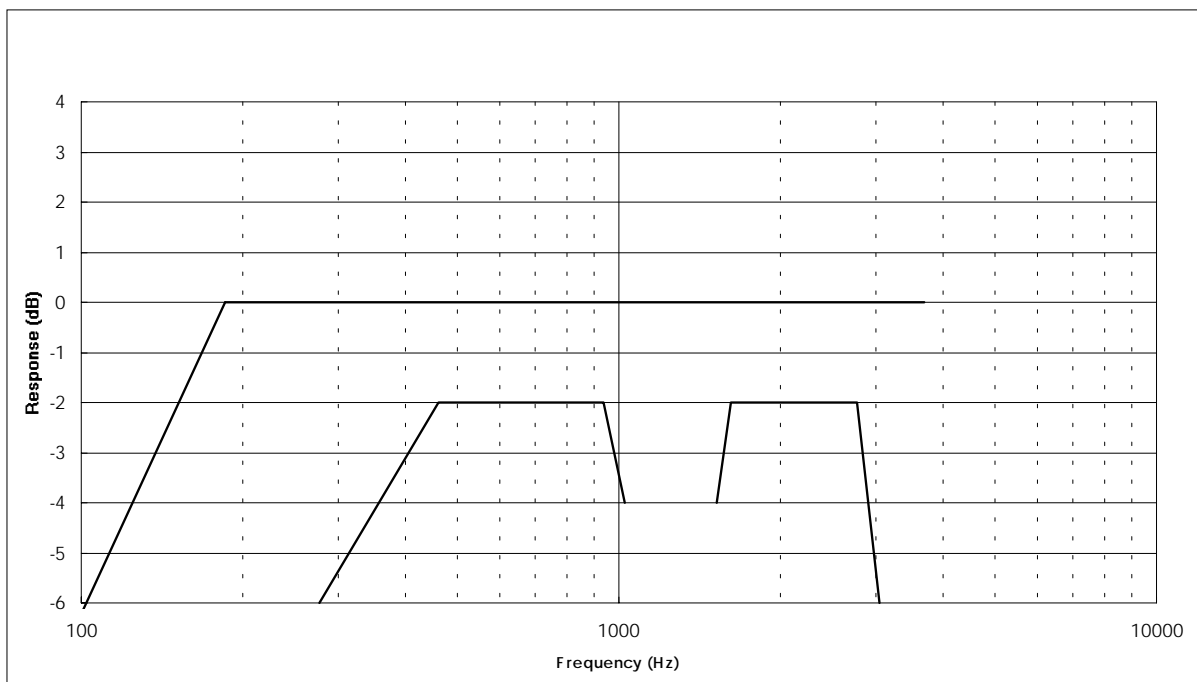
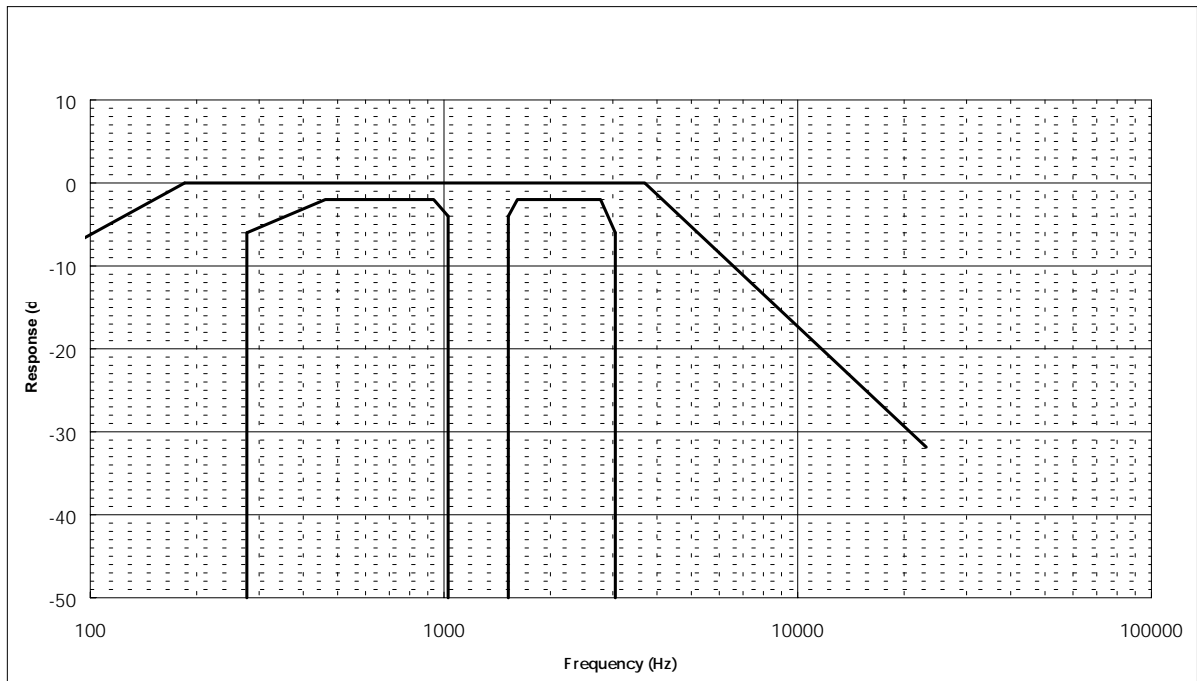




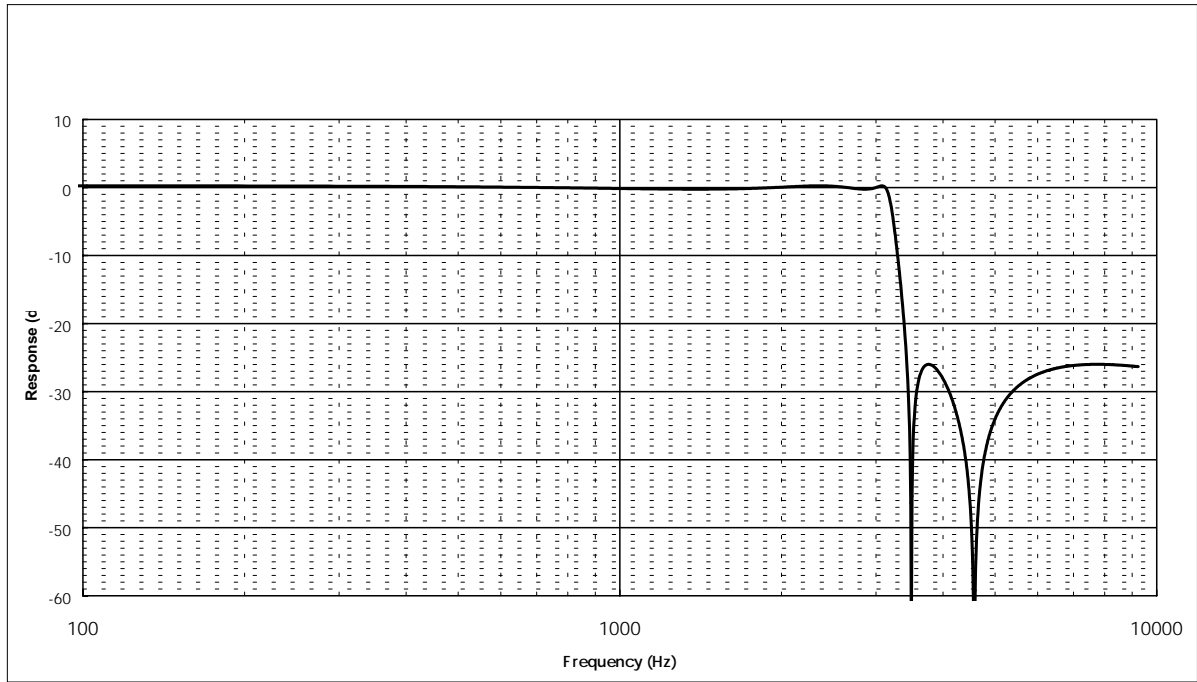
**Figure 4: Typical Response Envelope of Scramble Signal at MICO pin, relative to MICIN, with Split Point 2 Selected**



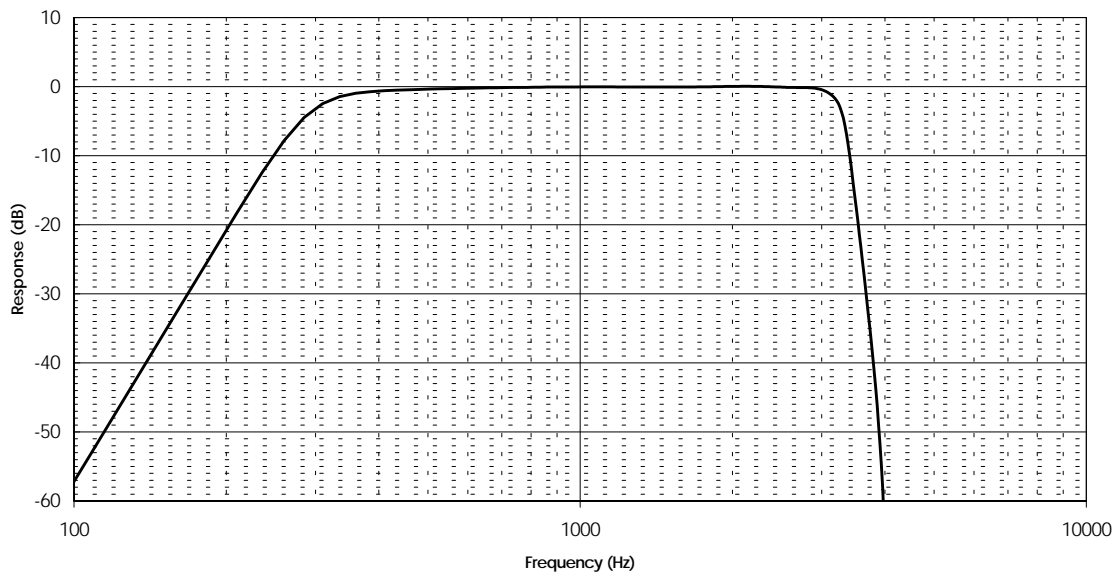
**Figure 5: Typical Response Envelope of Scrambled Signal at MICO pin, relative to MICIN, with Split Point 3 Selected**



**Figure 6: Typical Response Envelope of Scramble Signal at MICO pin, relative to MICIN, with Split Point 4 Selected**



**Figure 7: Typical Response of Upperband Transmit Output filter (TXUBOPF)**



**Figure 8: Typical Transmission Channel Filtering to Ensure Compliance with Statutory Transmission Requirement**

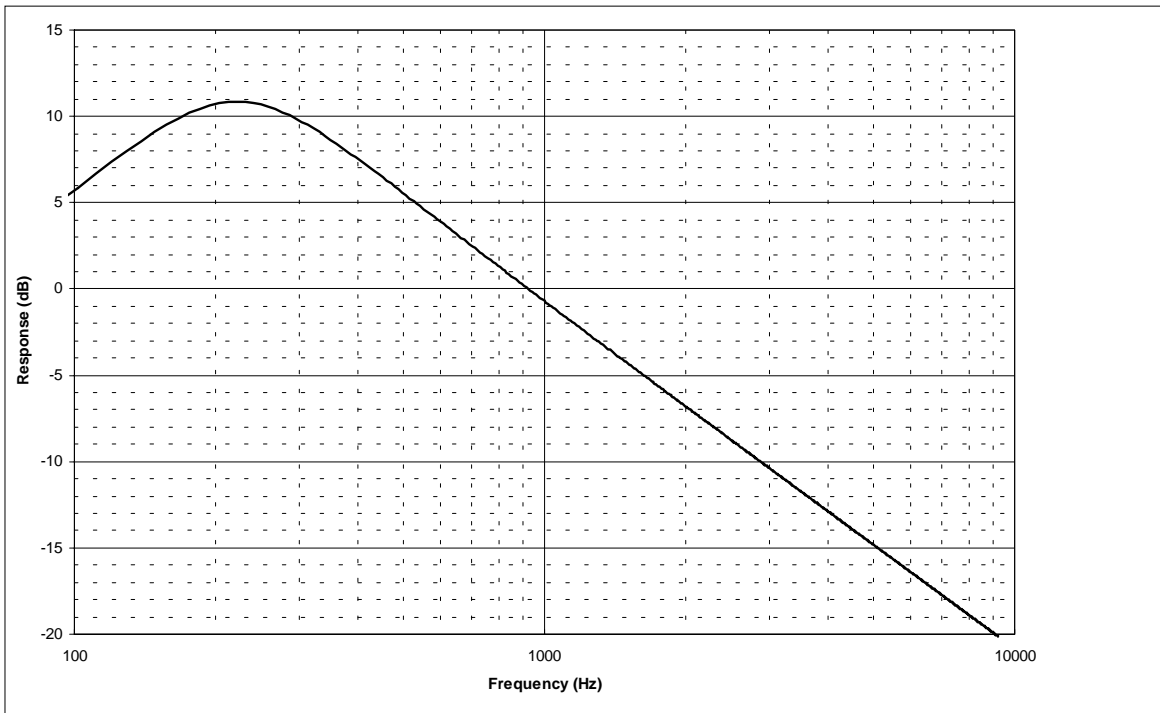
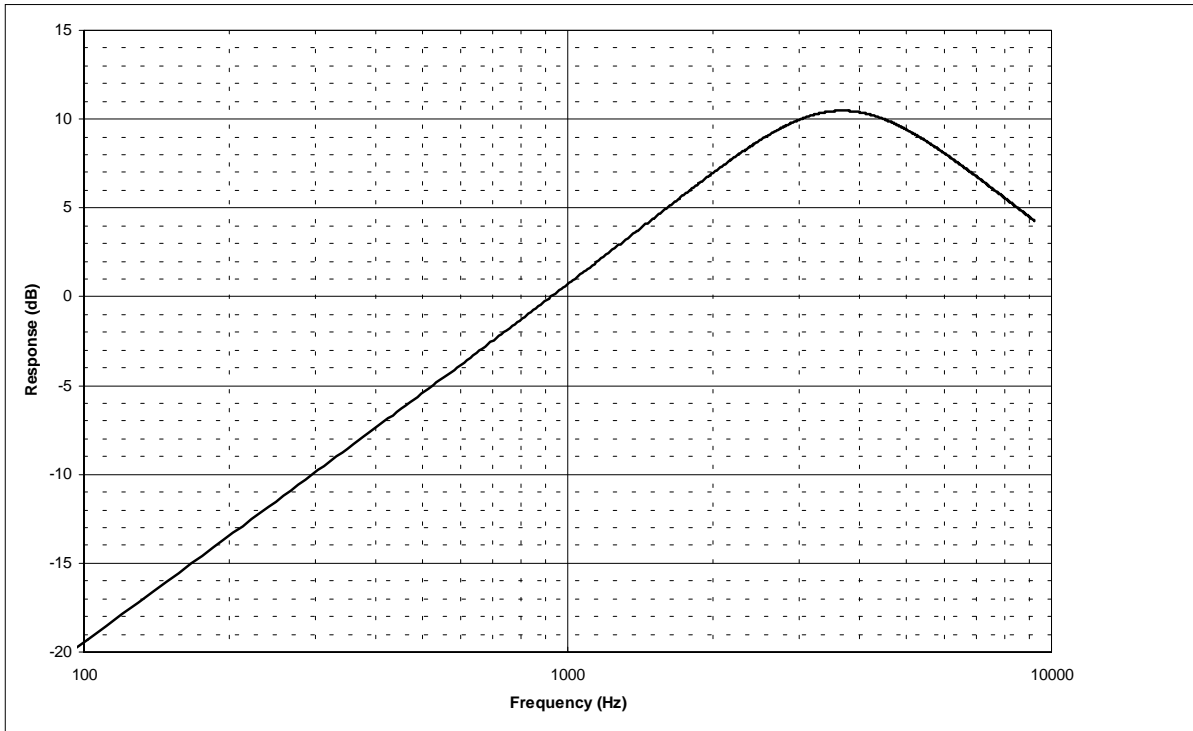


Figure 9: Typical Response of Pre-Emphasis and De-Emphasis Circuits

6.1.3.1 Timing Diagram

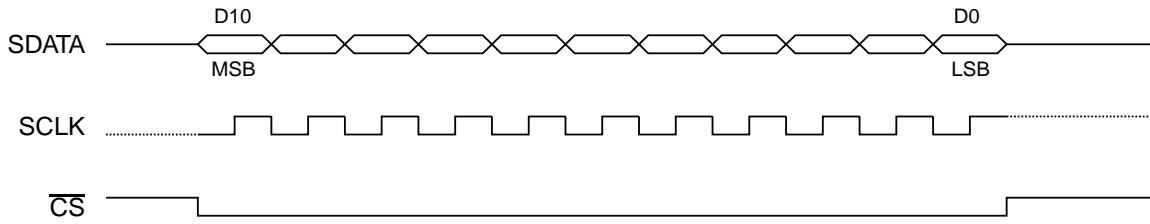
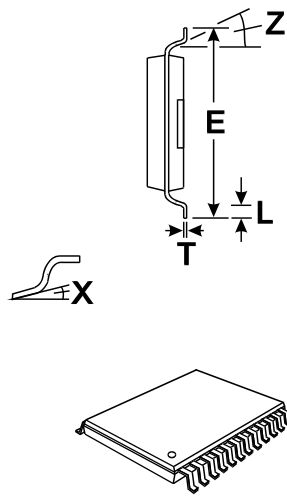
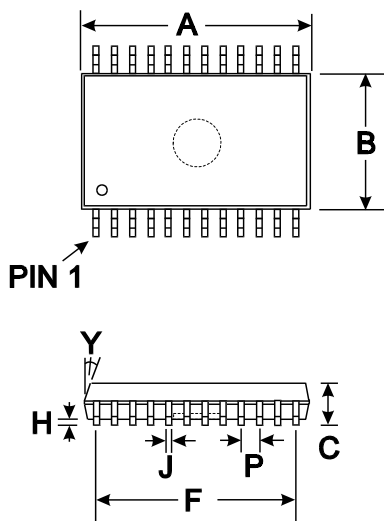


Figure 10: Serial Port Timing Diagram

6.2 Packaging



| DIM. | MIN.         | TYP.         | MAX.         |
|------|--------------|--------------|--------------|
| * A  | 0.318 (8.08) |              | 0.328 (8.33) |
| * B  | 0.205 (5.21) |              | 0.213 (5.39) |
| C    | 0.066 (1.67) |              | 0.079 (2.00) |
| E    | 0.301 (7.65) |              | 0.312 (7.90) |
| F    |              | 0.281 (7.15) |              |
| H    | 0.002 (0.05) |              | 0.008 (0.21) |
| J    | 0.010 (0.25) |              | 0.015 (0.38) |
| L    | 0.022 (0.56) |              | 0.037 (0.94) |
| P    |              | 0.026 (0.65) |              |
| T    | 0.005 (0.13) |              | 0.009 (0.23) |
| X    | 0°           |              | 8°           |
| Y    | 7°           |              | 9°           |
| Z    | 4°           |              | 10°          |

NOTE :

\* A & B are reference datum's and do not include mold flash or protrusions.

All dimensions in inches (mm).  
Angles are in degrees

Figure 11: 24-pin SSOP (D5) Mechanical Outline: Order as part no. CMX264D5