

MX-COM, INC. MiXed Signal ICs

DATA BULLETIN

MX609

PCN/PCS DELTA MODULATION CODEC

Features

- Single Chip full Duplex CVSD CODEC
- On-chip Input and Output Filters
- Programmable Sampling Clocks
- 3- or 4-bit Companding Algorithm
- Powersave Capabilities
- Low Power, 5.0V Operation

Applications

- Digital PCN/PCS Systems
- Digital Cordless Phones
- Digital Delay Lines
- Digital Voice Storage
- Multiplexers, Switches, and Phones
- Time Domain Scramblers

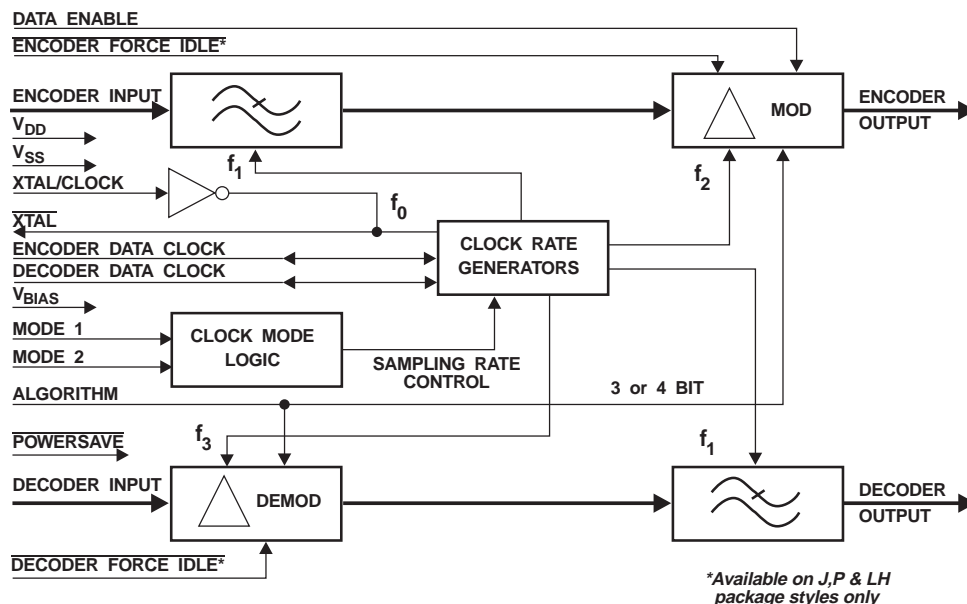

The MX609 is a Continuously Variable Slope Delta Modulation (CVSD) Codec designed for use in cordless telephones. The device is suitable for applications in delta multiplexers, switches and phones. Encoder input and decoder output switched capacitor filters are incorporated on-chip.

Sampling clock rates can be programmed to 16, 32 or 64K bits/second from an internal clock generator or externally injected in the 8 to 64K bits/second range. The internal clocks are derived from an on-chip reference oscillator driven by an externally connected crystal. The sampling clock frequency is output for the synchronization of external circuits.

The encoder has an enable function for use in multiplexer applications. When not enabled the encoder output remains in a high-impedance "tri-state" mode.

Companding circuits may be operated with an externally selectable 3- or 4-bit algorithm. The device may be put in standby mode when Powersave is selected.

The MX609 operates with a supply voltage of 5.0V and is available in the following packages: 24-pin PLCC (MX609LH), 16-pin SOIC (MX609DW), 22-pin Cerdip (MX609J), and 22-pin PDIP (MX609P).

CONTENTS

Section	Page
1 Block Diagram	3
2 Signal List	4
3 External Components	6
4 General Description	6
5 Application	7
5.1 CODEC Integration.....	7
5.2 CODEC Performance	7
6 Performance Specification	9
6.1 Electrical Performance	9
6.1.1 Absolute Maximum Ratings.....	9
6.1.2 Operating Limits	9
6.1.3 Operating Characteristics	10
6.1.4 TIMING.....	11
6.2 Packaging.....	12

MX-COM, Inc. reserves the right to change specifications at any time and without notice.

1 Block Diagram

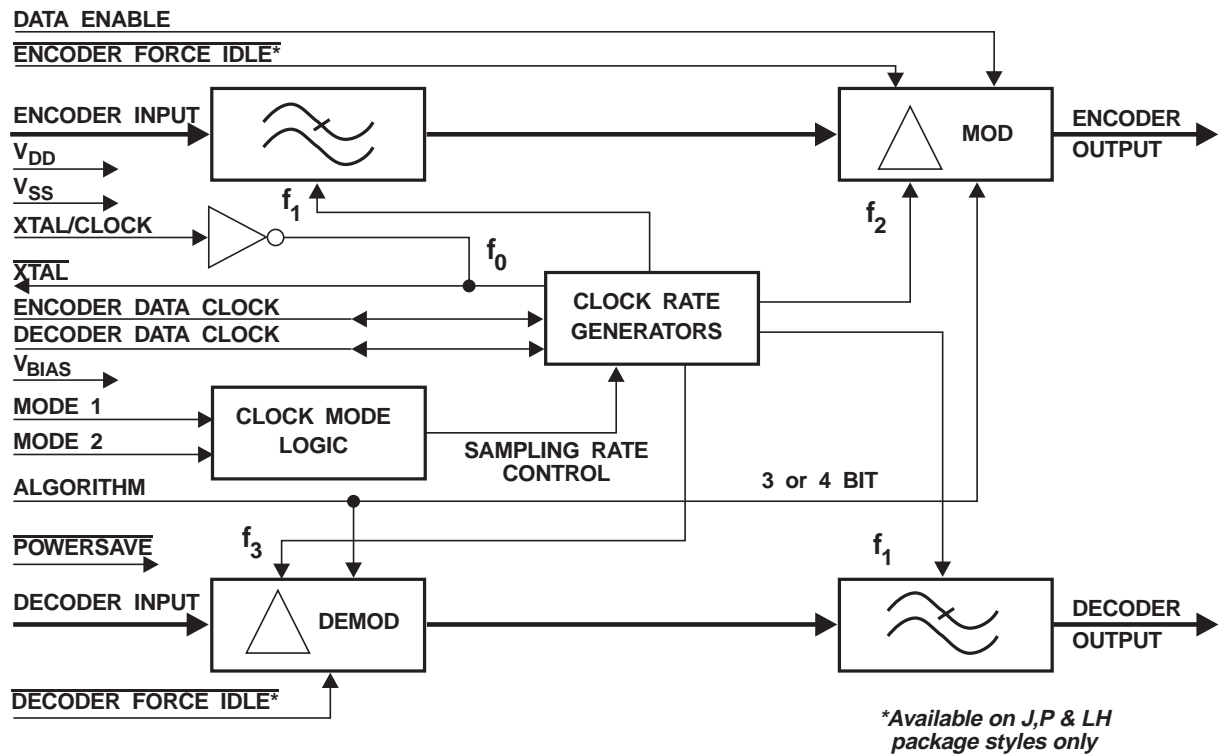

Figure 1: Block Diagram

2 Signal List

1	1	1	Xtal/Clock	input	Input to the clock oscillator inverter. A 1.024MHz Xtal input or externally derived clock is injected here. See Clock Mode pins and figure 3.
	2		N/C		
2	3	2	$\overline{\text{Xtal}}$	output	The 1.024 MHz output of the clock oscillator inverter.
3	4		N/C		No Connection
4	5	3	Encoder Data Clock	input/output	A logic I/O port. External encode clock input or internal data clock output. Clock frequency is dependent upon Clock Mode 1, 2 inputs and Xtal frequency (see Clock Mode pins).
5	6	4	Encoder Output	output	The encoder digital output. This is a three-state output whose condition is set by the Data Enable and Powersave inputs. See Table 2:
6	7	-	Encoder Force Idle		When this pin is at a logical "0" the encoder is forced to an idle state and the encoder digital output is 0101, a perfect idle pattern. When this pin is a logical "1" the encoder encodes as normal. Internal 1M Ω pullup.
7	8	5	Data Enable	input	Data is made available at the encoder output pin by control of this input. See Encoder Output pin. Internal 1 M Ω pullup.
8	9		N/C		No Connection
9	10	6	Bias		Normally at $V_{DD}/2$ bias, this pin should be externally decoupled by capacitor C4. Internally pulled to V_{SS} when "Powersave" is a logical "0".
10	11	7	Encoder Input	input	The analog signal input. Internally biased at $V_{DD}/2$, this input requires an external coupling capacitor. The source impedance should be less than 100 Ω . Output channel noise levels will improve with an even lower source impedance. See Figure 3.
11	12	8	V_{SS}	power	Negative Supply
12	13	-	N/C		No Connection
13	14	9	Decoder Output	output	The recovered analog signal is output at this pin. It is the buffered output of a lowpass filter and requires external components. During "Powersave" this output is open circuit.
14	15		N/C		No Connection
15	16	10	$\overline{\text{Powersave}}$		A logic "0" at this pin puts most parts of the codec into a quiescent non-operational state. When at a logical "1", the codec operates normally. Internal 1 M Ω pullup.
	17				No Connection
16	18	-	Decoder Force Idle		A logic "0" at this pin gates a 0101... pattern internally to the decoder so that the Decoder Output goes to $V_{DD}/2$. When this pin is a logical "1" the decoder operates as normal. Internal 1M Ω pullup.
17	19	11	Decoder Input		The received digital signal input. Internal 1 M Ω pullup.
18	20	12	Decoder Data Clock	input/output	A logic I/O port. External decode clock input or internal data clock output, dependent upon clock mode 1,2 inputs. See Clock Mode pins.
19	21	13	Algorithm		A logic "1" at this pin sets this device for a 3-bit companding algorithm. A logical "0" sets a 4-bit companding algorithm. Internal 1 M Ω pullup.

20	22	14	Clock Mode 2		Clock rates refer to $f = 1024\text{MHz}$ Xtal/Clock input. During internal operation the data clock frequencies are available at the ports for external circuit synchronization. Independent or common data rate inputs to Encode and Decode data clock ports may be employed in the External Clocks mode. Internal $1\text{M}\Omega$ pullups.
21	23	15	Clock Mode 1		
22	24	16	V_{DD}	power	Positive Supply. A single 5.0V supply is required.

Table 1: Signal List

Data Enable	Powersave	Encoder Output
1	1	Enable
0	1	High Z (open circuit)
1	0	V_{SS}

Table 2: Encoder Output

Clock Mode 1	Clock Mode 2	Facility
0	0	External Clocks
0	1	Internal, $64\text{kbps} = f/16$
1	0	Internal, $32\text{kbps} = f/32$
1	1	Internal, $16\text{kbps} = f/64$

Table 3: Clock Mode

3 External Components

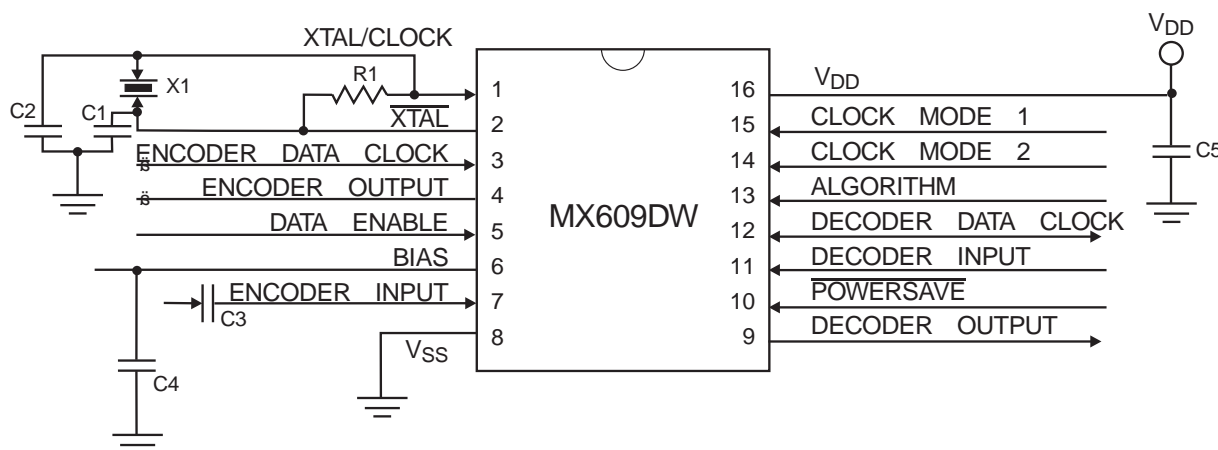

Figure 2: Recommended External Components for Typical Application

R1	Note 1	1M Ω	$\pm 10\%$	C4	Note 4	1.0 μ F	$\pm 20\%$
C1	Note 2	33pF	$\pm 20\%$	C5	Note 5	1.0 μ F	$\pm 20\%$
C2	Note 2	68pF	$\pm 20\%$	X1	Note 6, 7	1.024MHz	
C3	Note 3	1.0 μ F	$\pm 20\%$				

Table 4: Recommended External Components for Typical Application

Notes:

- Oscillator inverter bias resistor
- Xtal circuit load capacitor
- Encoder input coupling capacitor. The drive source impedance to this input should be less than 100 Ω . Output idle channel noise levels will improve with even lower source impedance.
- Bias decoupling capacitor
- VDD decoupling capacitor
- A 1.024MHz Xtal/Clock input will yield exactly 16/32/64kbps data clock rates. Xtal circuitry shown is in accordance with MX-COM's Xtal Oscillator Application Note.
- For best results, a crystal oscillator design should drive the clock inverter input with signal levels of at least 40% of V_{DD} , peak to peak. Tuning fork crystals generally cannot meet this requirement. To obtain crystal oscillator design assistance, please consult your crystal manufacturer.

4 General Description

The MX609 is a Continuously Variable Slope Delta Modulation (CVSD) Codec designed for use in cordless telephones. The device is suitable for applications in delta multiplexers, switches and phones. Encoder input and decoder output switched capacitor filters are incorporated on-chip.

Sampling clock rates can be programmed to 16, 32 or 64K bits/second from an internal clock generator or externally injected in the 8 to 64K bits/second range. The internal clocks are derived from an on-chip reference oscillator driven by an externally connected crystal. The sampling clock frequency is output for the synchronization of external circuits.

The encoder has an enable function for use in multiplexer applications. When not enabled the encoder output remains in a high-impedance "tri-state" mode.

Companding circuits may be operated with an externally selectable 3- or 4-bit algorithm. The device may be put in standby mode when Powersave is selected.

5 Application

5.1 CODEC Integration

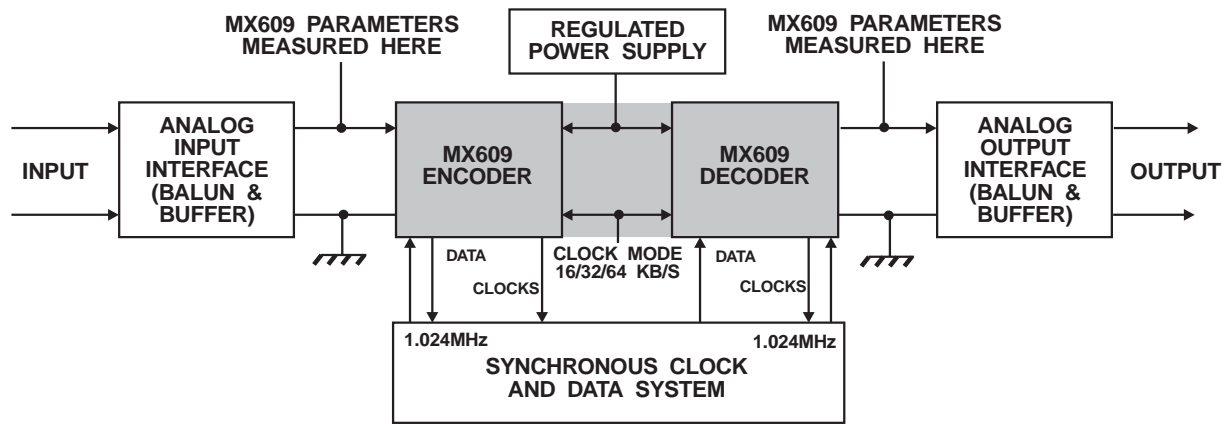

Figure 3: System Configuration using the MX609

5.2 CODEC Performance

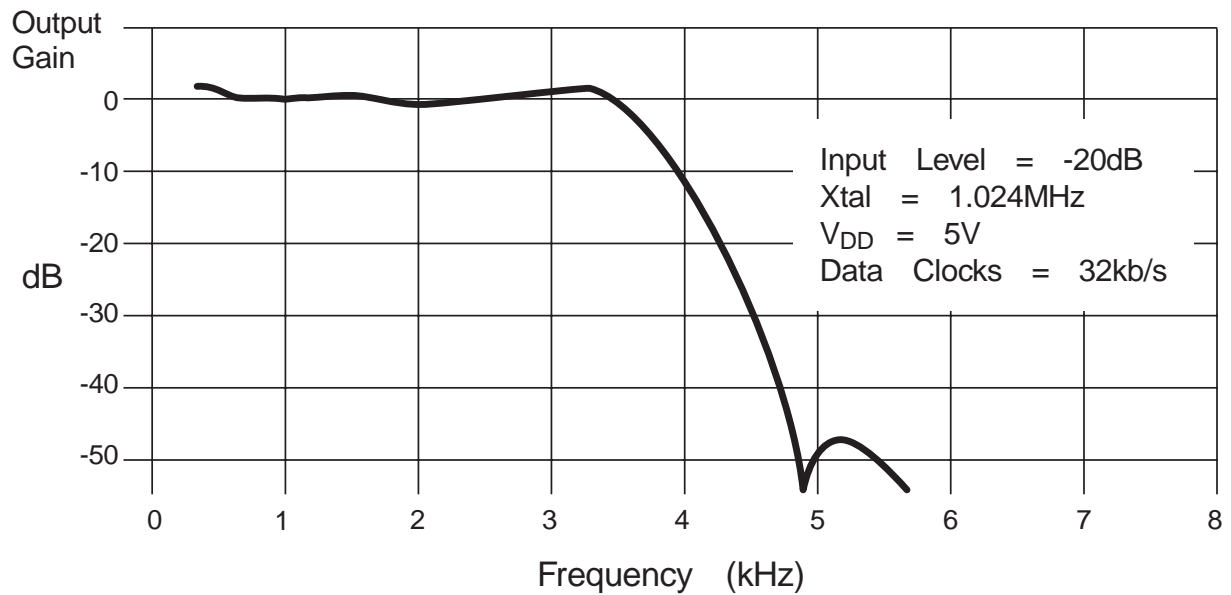

Figure 4: Typical CODEC Frequency Response

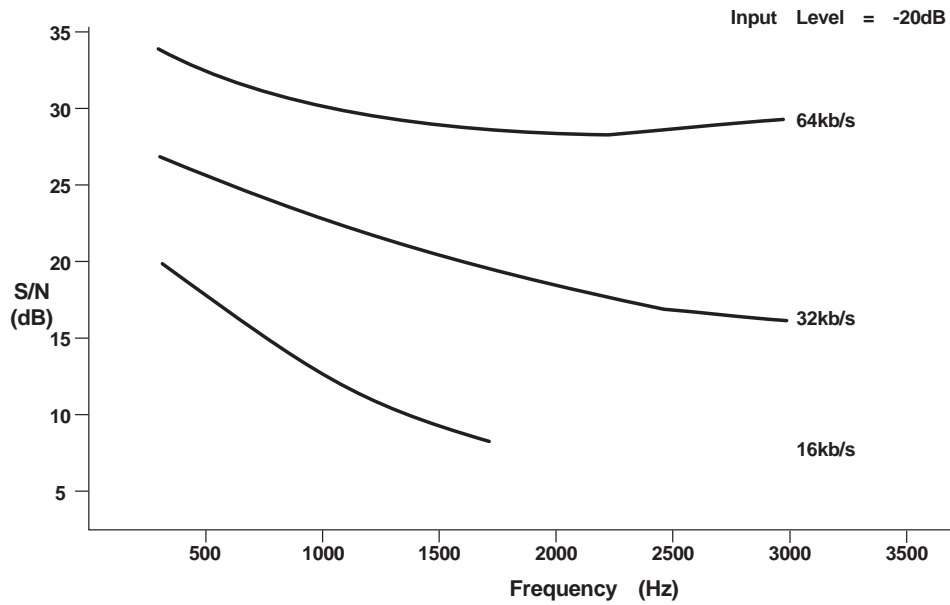

Figure 5: Typical S/N Ratio with Input Frequency

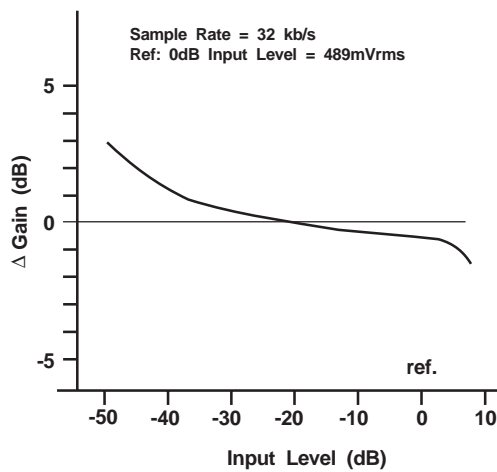

Figure 6: Typical Variation of Gain with Input Level

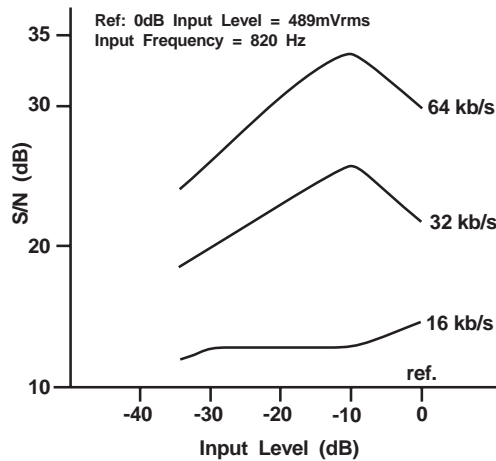

Figure 7: Typical S/N Ratio with Input Level

6 Performance Specification

6.1 Electrical Performance

6.1.1 Absolute Maximum Ratings

Exceeding these maximum ratings can result in damage to the device.

	Min.	Max.	Units
Supply ($V_{DD} - V_{SS}$)	-0.3	7.0	V
Voltage on any pin to V_{SS}	-0.3	$V_{DD} + 0.3$	V
Current			
V_{DD}	-30	30	mA
V_{SS}	-30	30	mA
any other pin	-20	20	mA
J / P / LH / DW Packages			
Total Allowable Power Dissipation at $T_{AMB} = 25^{\circ}\text{C}$	-	800	mW
Derating above 25°C	-	10	mW/ $^{\circ}\text{C}$ above 25°C
Storage Temperature	-40	85	$^{\circ}\text{C}$
Operating Temperature	-40	85	$^{\circ}\text{C}$

6.1.2 Operating Limits

Correct operation of the device outside these limits is not implied.

	Min	Typ.	Max.	Units
Supply ($V_{DD} - V_{SS}$)	4.5	5.0	5.5	V
Operating Temperature	-30		70	$^{\circ}\text{C}$
Xtal Frequency	500	1.024	1500	MHz

6.1.3 Operating Characteristics

For the following conditions unless otherwise specified:

$V_{DD} = 5.0V$ at $T_{AMB} = 25^{\circ}C$, Audio Test Frequency = 820Hz Xtal/Clock $f_0 = 1.024MHz$

Sample Clock Rate = 32kbps, Audio level 0dB ref (0 dBm0) = 489mV_{RMS}.

	Note s	Min.	Typ.	Max.	Units
Static Values					
Supply Voltage	1	4.5	5.0	5.5	V
Supply Current (Enabled)			3.5		mA
Supply Current (Powersave)			500		μA
Input logic '1'		3.5			V
Input Logic '0'				1.5	V
Output Logic '1'		4.0			V
Output Logic '0'				1.0	V
Digital input Impedance					
Logic I/O pins			10		M Ω
Logic Input pins, Pullup Resistor	2	300			k Ω
Digital output impedance			4		k Ω
Analog Input Impedance			100		k Ω
Analog Output Impedance	6		800		Ω
Three State Output Leakage			± 4		μA
Insertion Loss	2		0		dB
Dynamic Values					
Encoder	1				
Analog signal Input levels	6	-30		8	dB
Principal Integrator Frequency			275		Hz
Encoder passband			3400		Hz
Compand Time Constant			4		ms
Decoder					
Analog Signal Output Levels	6	-30	0	8	dB
Decoder Passband	3		3400		Hz
Encoder Decoder (Full Codec)					
Passband		300		3400	Hz
Stopband		6		10	KHz
Stopband Attenuation			60		dB
Passband Gain			0		dB
Passband Ripple		-3		3	dB
Output Noise (Input Short Circuit)			-60		dB
Perfect Idle Channel Noise					
(Encode Forced)	7		-63		dB
Group Delay Distortion	4				
(1000Hz-2600Hz)				450	μs
(600Hz-2800Hz)				750	μs
(500Hz-3000Hz)				1.5	μs
Xtal/clock Frequency		500	1024	1500	kHz

Notes:

1. Dynamic characteristics specified at 5.0V only.
2. All logic inputs except Encoder and Decoder Data clocks
3. With passband gain of ± 1 dB.
4. Group Delay Distortion for the full codec is relative to the delay with and 820Hz, -20dB signal at the encoder input
5. Relative timings are shown in figure 4
6. Recommended values
7. Forced idle Encode/Decode not available on DW package.

6.1.4 TIMING

Serial Bus Timings (See Figure 8)		Min.	Typ.	Max.	Units
t_{CH}	Clock 1 pulse width	1.0			μ S
t_{CL}	Clock 0 pulse width	1.0			μ S
t_{IR}	Clock rise time	0	100		ns
t_{IF}	Clock fall time		100		ns
t_{SU}	Data set-up time			450	ns
t_H	Data hold time	600			ns
$t_{SU} + t_H$	Data true time		1.5		μ S
t_{PCO}	Clock to output delay time		750		ns
t_{DR}	Data rise time		100		ns
t_{DF}	Data fall time		100		ns

Xtal input frequency = 1.024MHz

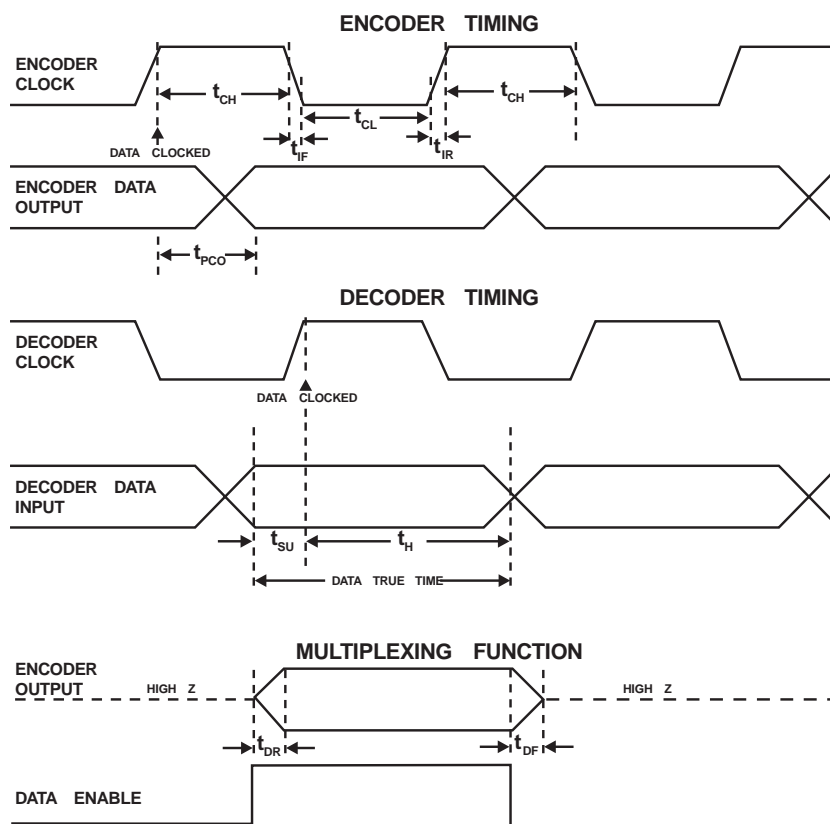
**Figure 8: Serial Bus Timing**

6.2 Packaging

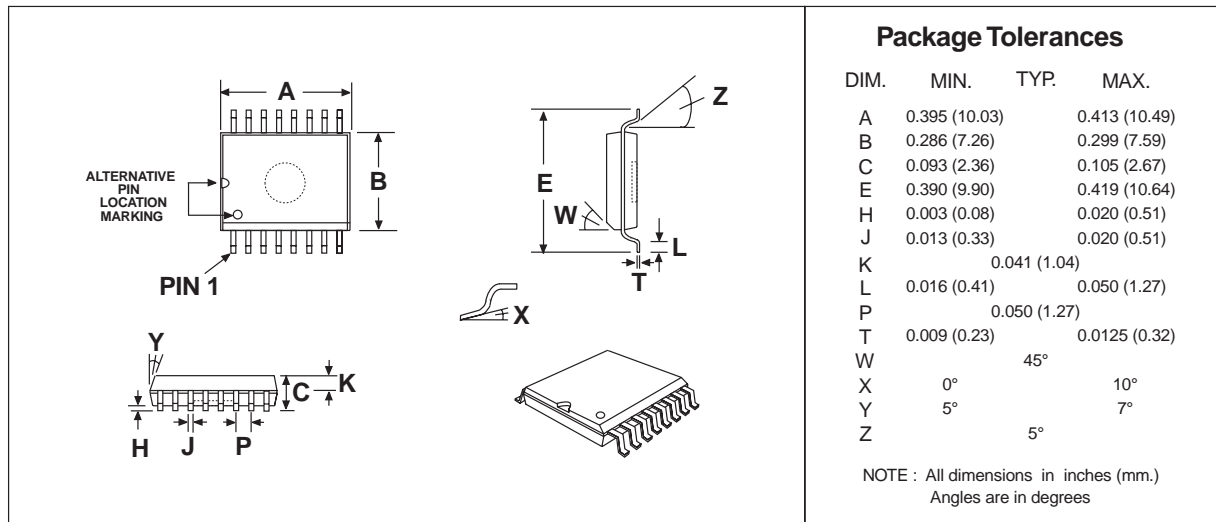

Figure 9: 16-pin SOIC (DW) Mechanical Outline: *Order as part no. MX609DW*

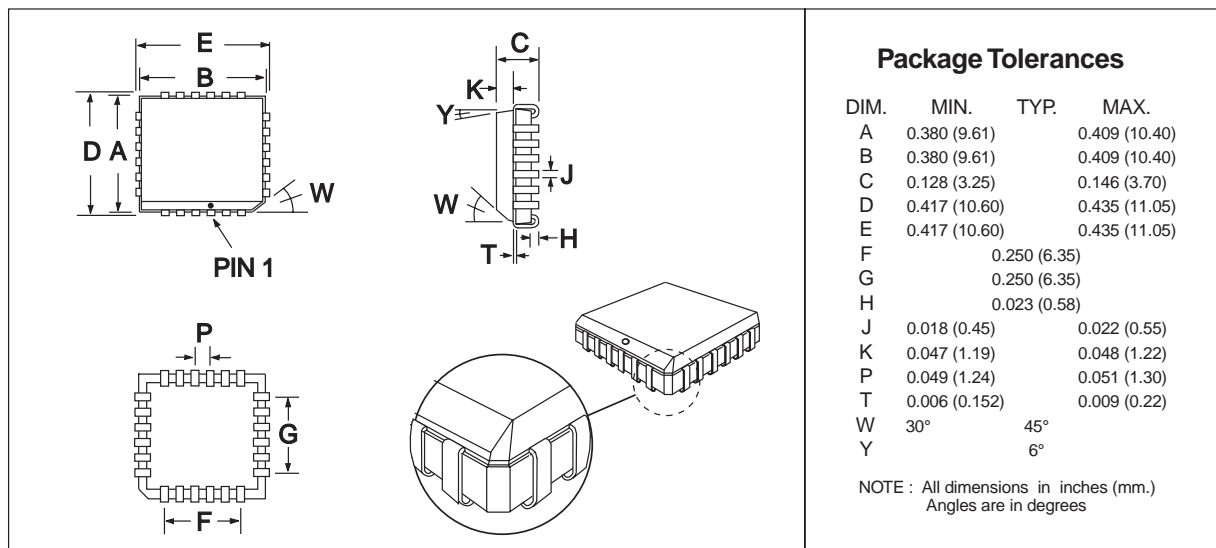

Figure 10: 24-pin PLCC (LH) Mechanical Outline: *Order as part no. MX609LH*

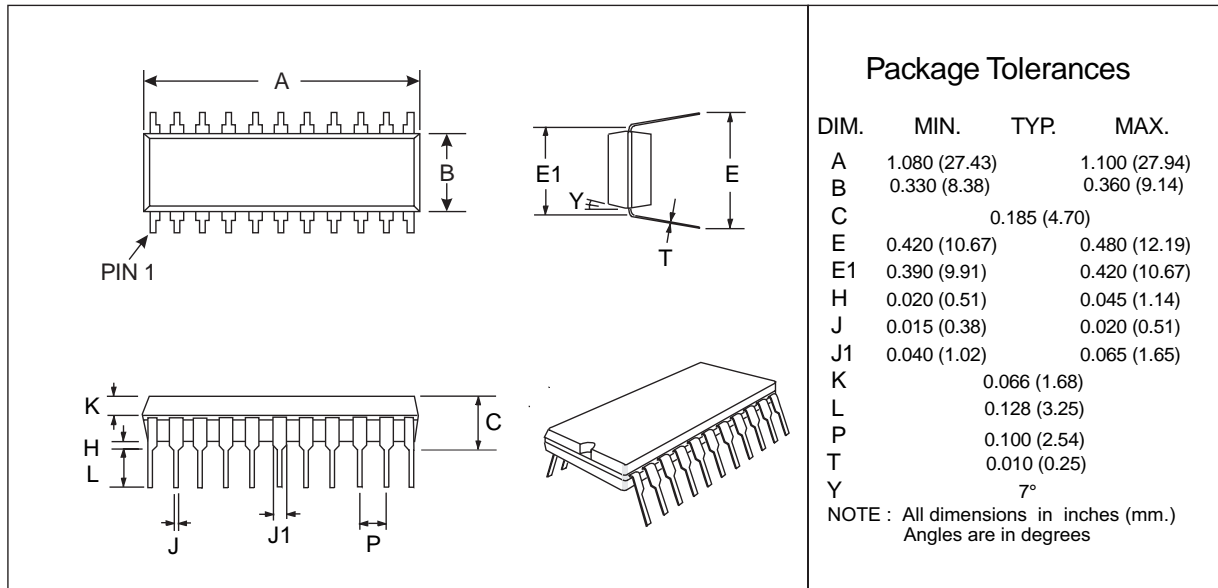

Figure 11: 22-pin PDIP (P) Mechanical Outline: Order as part no. MX609P

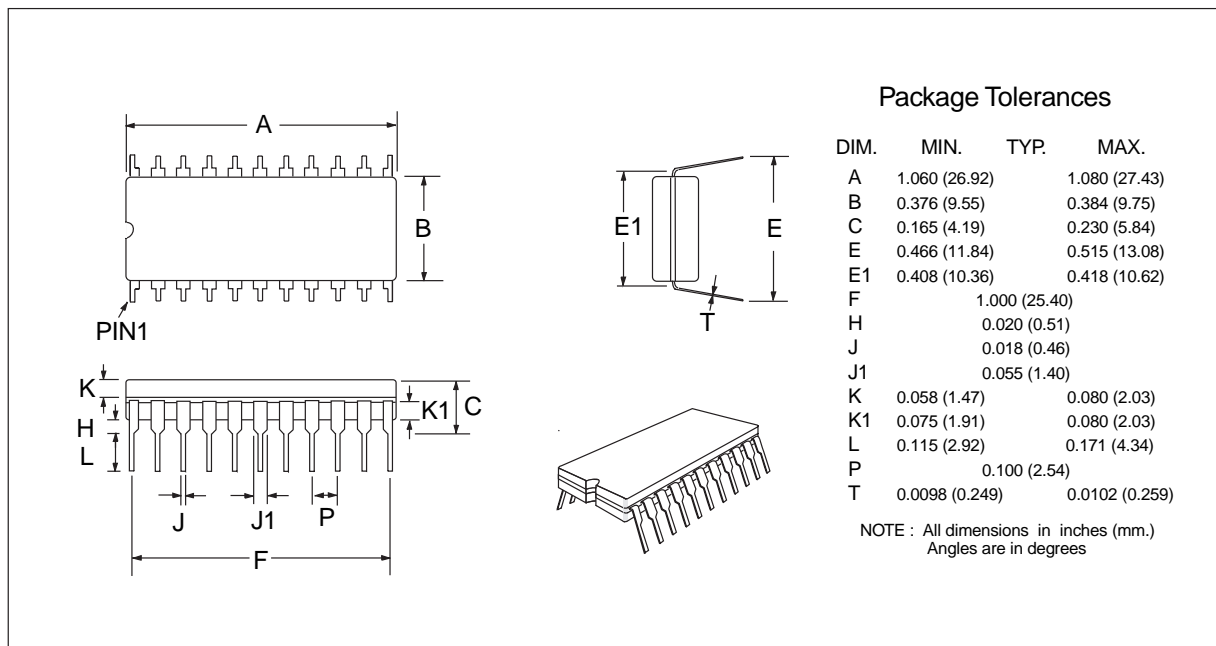

Figure 12: 22-pin Cerdip (J) Mechanical Outline: Order as part no. MX609J