

MX-COM, INC. MiXed Signal ICs

DATA BULLETIN

MX806A

Audio Processor

Features

- Half-Duplex Audio Processor
- Dynamic Control of Signal Levels
- Performs Signal Conditioning and Filtering requirements for both Transmit and Receive
- Three separate signal sections:
 - Input process
 - Main Process
 - Mixing and Output Drives
- Low Power Operation
- Member of DBS800 Family (C-BUS Compatible)

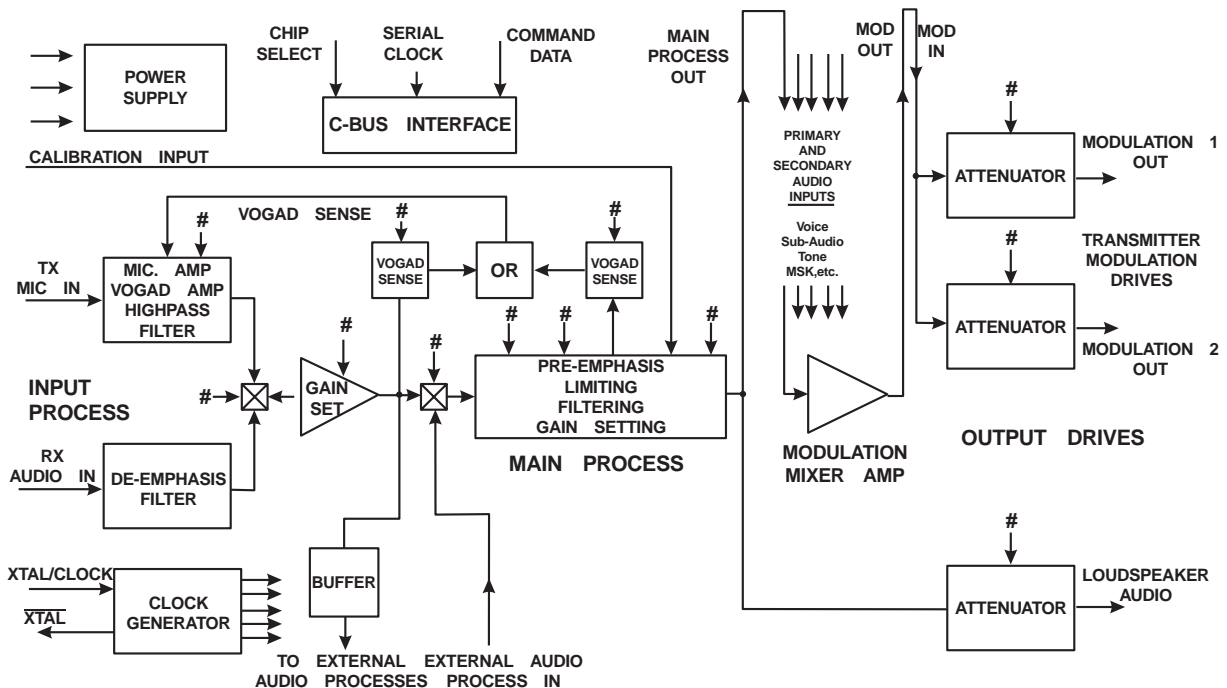

The MX806A LMR audio processor is intended too primarily to operate as the “Audio Terminal” or radio systems using the DBS800 Digitally Integrated Baseband Subsystem.

The MX806A half-duplex device has signal paths and level setting elements that are configured and adjusted by digital information sent from the radio microcontroller using C-BUS protocol. (C-BUS is the serial interface for all DBS 800 ICs.)

The Signal Path is divided into three sections: Input Process, Main process, and Mixing and Output Drives.

If selected, signal level stability and output accuracy of the MX806A is maintained by a voltage-controlled gain system using selectable signal-level detectors. Signal levels can be dynamically controlled to provide “dynamic compensation” for factors such as temperature drift, VCO non-linearity, etc.

The MX806A audio stages can be completely disabled – or the whole IC can be placed into powersave mode, leaving only clock and C-BUS circuitry active.

The MX806A may be used with a 5.0V power supply and is available in the following packages: 24-pin SOIC (MX806ADW), 24-pin PLCC (MX806ALH), and 24-pin PDIP (MX806AP).

Contents

| Section | Page |
|--|-----------|
| 1 Block Diagram | 3 |
| 2 Signal List | 4 |
| 3 External Components | 6 |
| 4 General Description | 7 |
| 4.1 Signal Path | 7 |
| 4.2 VOGAD..... | 7 |
| 4.2.1 VOGAD Components Calculations – Figure 2 and Figure 5..... | 8 |
| 4.3 Calibration Methods..... | 8 |
| 4.3.1 TX Calibration: From Mic. In to Modulator Drives Out | 8 |
| 4.3.2 RX Calibration: From RX Audio In to Audio Out | 8 |
| 5 Controlling Protocol | 10 |
| 5.1.1 Control Command – (Preceded by A/C 10H)..... | 11 |
| 5.1.2 Mode Command – (Preceded by A/C 11H) | 12 |
| 5.1.3 Modulator Levels – (Preceded by A/C 12H) | 13 |
| 5.1.4 Volume Set – (Preceded by A/C 13H) | 15 |
| 6 Application Notes | 16 |
| 7 Performance Specifications | 17 |
| 7.1 Electrical Specifications..... | 17 |
| 7.1.1 Absolute Maximum Limits | 17 |
| 7.1.2 Operating Limits..... | 17 |
| 7.1.3 Operating Characteristics | 18 |
| 7.1.4 Timing | 21 |
| 7.2 Packages..... | 22 |

| |
|---|
| MXCOM, Inc. reserves the right to change specifications at any time without notice. |
|---|

1 Block Diagram

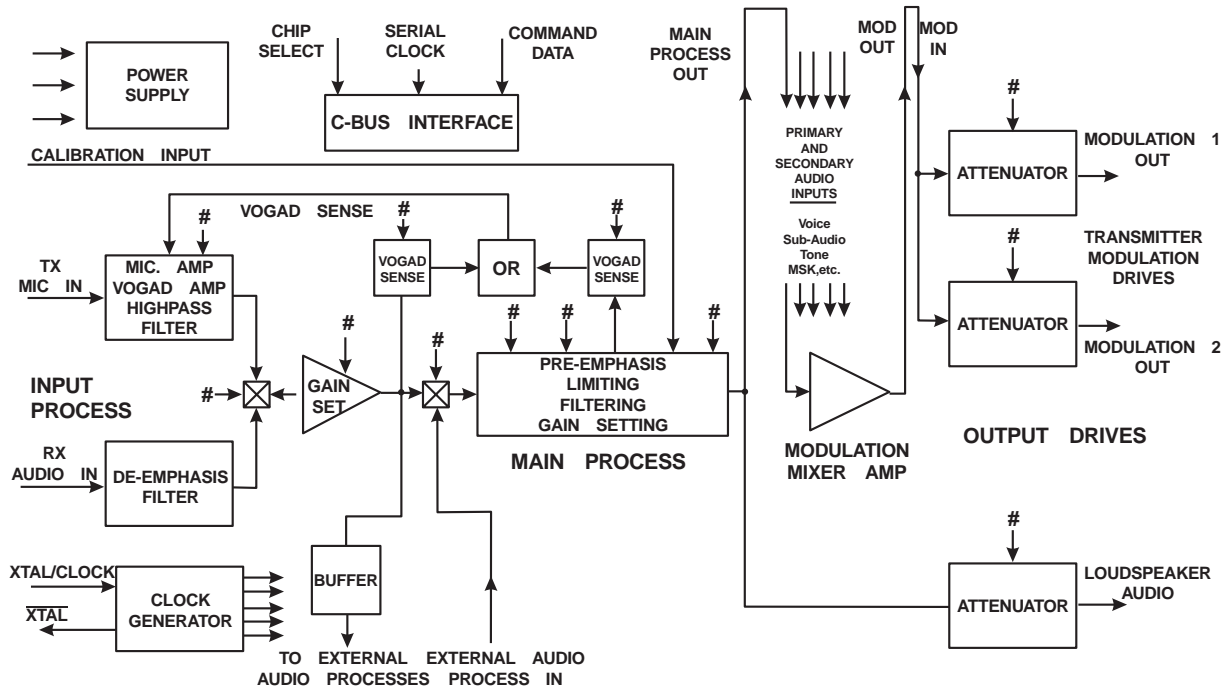

Figure 1: Block Diagram

2 Signal List

| Pin | Signal | Description |
|-----|--------------------------|--|
| 1 | $\overline{\text{Xtal}}$ | The output of the 4.032MHz on-chip clock oscillator. External components are required at this output when a Xtal is used. See Figure 2. |
| 2 | Xtal/Clock | The input to the on-chip 4.032MHz clock oscillator inverter. A 4.032MHz Xtal or externally derived clock should be connected here. See Figure 2. This clock provides timing for on-chip elements, filters, etc. |
| 3 | Serial Clock | This is the 'C-BUS' serial Clock input. This clock, produced by the microcontroller, is used for transfer timing of commands and data to and from the MX805A. See Section 6 and Section 7.1.4. |
| 4 | Command Data | This is the 'C-BUS' serial data input from the microcontroller. Command Data is loaded to this device in 8-bit bytes, MSB (bit 7) first and LSB (bit 0) last, synchronized to the Serial Clock. The Command/Data instruction is acted upon at the end of loading the whole instruction. Command information is detailed in Table 3 through Table 7. See Section 6 and Section 7.1.4. |
| 5 | $\overline{\text{CS}}$ | Chip Select. This is the 'C-BUS' data loading control function. This input is provided by the microcontroller. Command Data transfer sequences are initiated, completed or aborted by the $\overline{\text{CS}}$ signal. See Section 6 and Section 7.1.4. |
| 6 | VOGAD OUT | The error-voltage output of the selected VOGAD sensor. This output, with external attack and decay setting components, should be connected as in Figure 2 and Figure 3, to the VOGAD In pin. |
| 7 | RX Audio In | The audio input to the MX806A from the radio receiver's demodulator circuits. This input, which requires AC coupling with capacitor C12, is selected via a Control Command bit. |
| 8 | VOGAD In | The gain control signal from the selected VOGAD sensor (VOGAD Out) to the Input Process voltage-controlled amplifier. The required sensor is selected via a Mode Command. The choice of two sensors enables gain control from either the Input Process or an External Process. External attack and decay setting components should be applied as recommended. See Figure 2 and Figure 3. |
| 9 | V_{BIAS} | The output of the on-chip analog circuitry bias system, held internally at $V_{\text{DD}}/2$. This pin should be decoupled to V_{SS} by capacitor C10. See Figure 2. |
| 10 | Mic In (+) | The non-inverting input to the microphone Op-Amp. This input requires external components for Op-Amp gain/attenuation setting as shown in Figure 2. |
| 11 | Mic In (-) | The inverting input to the microphone Op-Amp. This input requires external components for Op-Amp gain/attenuation setting as shown in Figure 2. |
| 12 | V_{SS} | Negative Supply (GND) |
| 13 | Mic Out | The output of the Microphone Op-Amp, used with the Mic In (-) input to provide the required gain/attenuation using external components as shown in Figure 2. The external components shown are to assist in the use of this amplifier with either inverting or non-inverting inputs. During Powersave (Volume Command this output is placed at V_{SS} .) |
| 14 | Processed Audio In | The input to the device from such external audio processed as Voice Store and Retrieve or Frequency Domain Scrambling. This input, which requires AC Coupling with capacitor C13, is selected by a Mode Command bit. |
| 15 | External Audio Process | The buffered output of the Input Processing Stage. Its purpose is to further external audio processing stages prior to re-introduction at the Processed Audio In Pin. |
| 16 | Calibration Input | A unique audio input to be used for dynamic balancing of the modulator drives for measuring Deviation Limiter levels. A CUE (beep) input from the MX803 Audio Tone Processor can be entered on this line. This audio input must be externally biased. It is selected via a Mode Command bit. |
| 17 | Main Process Out | The output of the Main Process stage. This output should be mixed with any additional system audio inputs (Audio, Sub-Audio Signaling, MSK) in the on-chip Modulation Summing Amplifier. External components shown in Figure 2 should be used as required. |

| Pin | Signal | Description |
|-----|--------------------|--|
| 18 | Sum In | The input and output terminals of the on-chip Modulation Summing Amplifier. External components are required for input signals and gain/attenuation setting as shown in Figure 2. For single-signal, no gain requirements, Main Process Out may be linked directly to Modulation In. |
| 19 | Sum Out | |
| 20 | Modulation In | The final, composite modulating signal to VCO (Mod 1) and Reference (Mod 2) Output Drives |
| 21 | Audio Output | The processed audio signal output intended as a received audio (volume) output. Though normally used in the RX mode, operation in TX is permitted. The output level of this attenuator is controlled via a Volume Set command. During Powersave this output is placed at V_{SS} . |
| 22 | Modulation 1 Drive | The drive to the radio modulator Voltage Controlled Oscillator (VCO) from the composite audio summing stage. |
| 23 | Modulation 2 Drive | The drive to the radio modulator Reference Oscillator from the composite audio summing stage. Note: These VCO output attenuators are individually adjustable using the Modulator Level command. During Powersave these outputs are placed at V_{SS} . |
| 24 | V_{DD} | Positive Supply. A single 5.0V regulated supply is required. Levels and voltages within this Audio Processor are dependent upon this supply. |

Table 1: Signal List

3 External Components

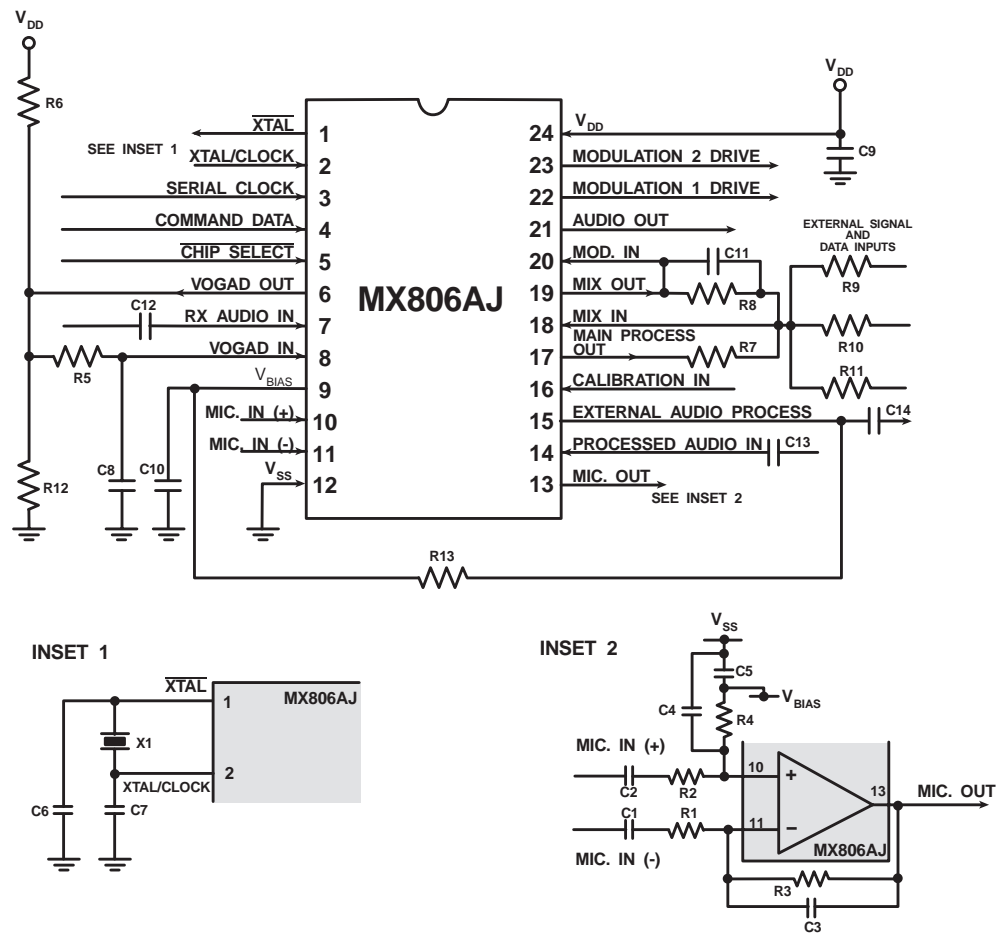

Figure 2: Recommended External Components

| Component | Notes | Value | Tolerance |
|-----------|-------|-------|-----------|
| R1 | | 10kΩ | ±10% |
| R2 | | 10kΩ | ±10% |
| R3 | | 20kΩ | ±10% |
| R4 | | 20kΩ | ±10% |
| R5 | | 10kΩ | ±10% |
| R6 | | 2.2MΩ | ±10% |
| R7 | | 100kΩ | ±10% |
| R8 | | 100kΩ | ±10% |
| R9 | | 100kΩ | ±10% |
| R10 | | 100kΩ | ±10% |
| R11 | | 100kΩ | ±10% |
| R12 | | 2.2MΩ | ±10% |
| R13 | | 470kΩ | ±10% |
| C1 | | .47μF | ±20% |

| Component | Notes | Value | Tolerance |
|-----------|-------|---------|-----------|
| C2 | | .47μF | ±20% |
| C3 | | 270pF | ±20% |
| C4 | | 270pF | ±20% |
| C5 | | 0.1μF | ±20% |
| C6 | | 33pF | ±20% |
| C7 | | 5-65pF | ±20% |
| C8 | | 1.0μF | ±20% |
| C9 | | 1.0μF | ±20% |
| C10 | | 1.0μF | ±20% |
| C11 | | 22pF | ±20% |
| C12 | | 0.1μF | ±20% |
| C13 | | 0.01μF | ±20% |
| C14 | | 0.01μF | ±20% |
| X1 | | 4.00MHz | |

Table 2: Recommended External Components

Recommended External Component Notes:

1. Input Op-Amp gain/attenuation components (voltage gain = 6.0dB) are shown in Inset 1 is a differential configuration to demonstrate the versatility of this input. Components for a single (+ or -) input may be used.
2. Resistor values R7 to R11 (summation components) are dependent upon application and configuration requirements.
3. Xtal circuit capacitors C6 (CD) and C7 (CG) shown in Inset 2 are recommended in accordance with MX-COM's Crystal Oscillator Application Note. Circuit drive and drain resistors are incorporated on-chip. Operation of any MX-COM IC without a Xtal clock input may cause device damage. To minimize damage in the event of a Xtal/drive failure, you should install a current limiting device (resistor or fast-reaction fuse) on the power-input (V_{DD}).

4 General Description

The MX806A LMR audio processor is intended too primarily to operate as the "Audio Terminal" or radio systems using the DBS800 Digitally Integrated Baseband Subsystem.

The MX806A half-duplex device has signal paths and level setting elements that are configured and adjusted by digital information sent from the radio microcontroller using C-BUS protocol. (C-BUS is the serial interface for all DBS 800 ICs.)

4.1 Signal Path

The Signal path is divided into three sections:

Input Process: This stage has selectable TX/RX paths. Transmits voice signals pass through microphone pre-amplifier, voltage controlled gain (VOGAD) and highpass filter stages. Received audio is de-emphasized. This initial audio, after line-in gain adjustment, may be switched to external audio processes (such as scrambling) or to the internal Main Process stages.

Main Process: Conditioning for the input or external process signals is completed in this stage. It is comprised of pre-emphasis, high and lowpass switched capacitor filters and a deviation limiter.

Mixing and Output Drives: Main audio for transmission is mix with signaling and data from external sources (other DBS 800 ICs) to provide the composite signal for the digitally adjustable transmitter modulation drives. Received audio level is adjusted for output to loudspeaker circuitry.

If selected, signal level stability and output accuracy of the MX806A is maintained by a voltage-controlled gain system using selectable signal-level detectors. Signal levels can be dynamically controlled to provide "dynamic compensation" for factors such as temperature drift, VCO non-linearity, etc.

The MX806A audio stages can be completely disabled – or the whole IC can be placed into powersave mode, leaving only clock and C-BUS circuitry active.

4.2 VOGAD

The overall Gain Control system of the MX806A consists of 2 selectable signal peak detectors whose output is fed via external integrating components to adjust the gain of the Voltage Controlled Amplifier positioned in the TX Input Process Path. The transmit input signals is presented to Peak Detector 1 or 2. The Peak Detectors are enabled individually by a Mode Command. When the input signal exceeds the peak - to - peak threshold of the detector, a 5-volt level is produced at the VOGAD Out pin. This level remains for as long as the signal exceeds the threshold. The integrated level to the VOGAD In pin causes the Voltage Controlled Amplifier gain to be reduced. As can be seen from Figure 3 and Figure 5, Peak Detector 1 allows control of the audio level to the external audio process and Peak Detector 2 allows control of transmit deviation levels.

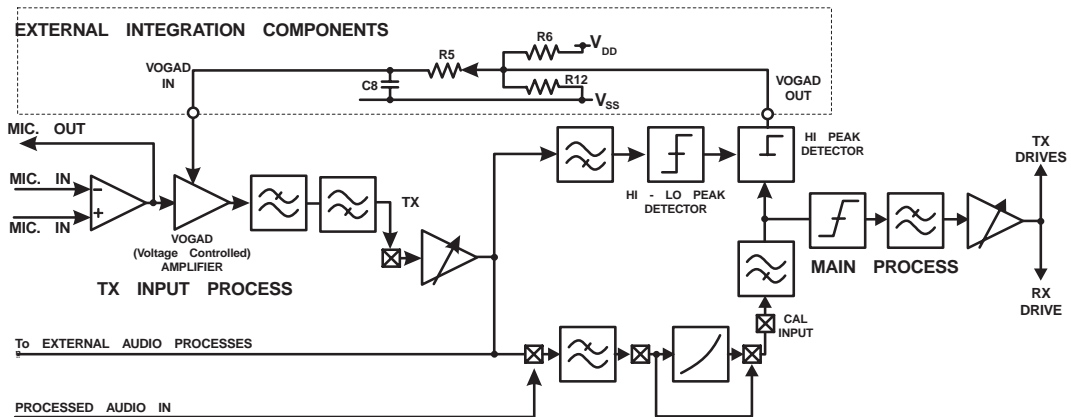

Figure 3: VOGAD Sensors and Timing Components (from Figure 5)

VOGAD attack and decay times are set using the external components shown in Figure 2 and Figure 3. They are calculated as described below.

4.2.1 VOGAD Components Calculations – Figure 2 and Figure 5

Provided $R5 \gg 1.0k$ and $R6 = R12 \gg R5$

Then

$$\text{Attack Time } (T_A) = R5 \times C8$$

$$\text{Decay Time } (T_D) = \frac{R6 \times C8}{2}$$

4.3 Calibration Methods

To effectively null all internal IC tolerance, the following initial calibration routine is suggested.

4.3.1 TX Calibration: From Mic. In to Modulator Drives Out

Disable Peak Detectors (Mode Command)

Set Transmitter Drives to 0dB (Mod. Levels Set)

Pre-emphasis may be employed as required (Control Command)

Set Input Level Amp to 0dB Control Command)

1. Mic. In = 250mVRMS at 1kHz. Set Process Gain Amp for output of 1440mV_{P-P} (100% deviation).
2. With Process Gain Amp set as 1 and with Mic. In = 25mV_{RMS} at 1kHz, set the Input Level Amp for an output level of 308mV_{RMS} (60% deviation)

4.3.2 RX Calibration: From RX Audio In to Audio Out

Set Audio Output Drive In to Audio Out

Leave Process Gain Amp set as 1 (See Section 4.3.1)

3. With and RX Audio In level of between 154mV_{RMS} and 308mV_{RMS} (See Section 7) at 1kHz, set the Input Level Amp for and output level of 308mV_{RMS}.

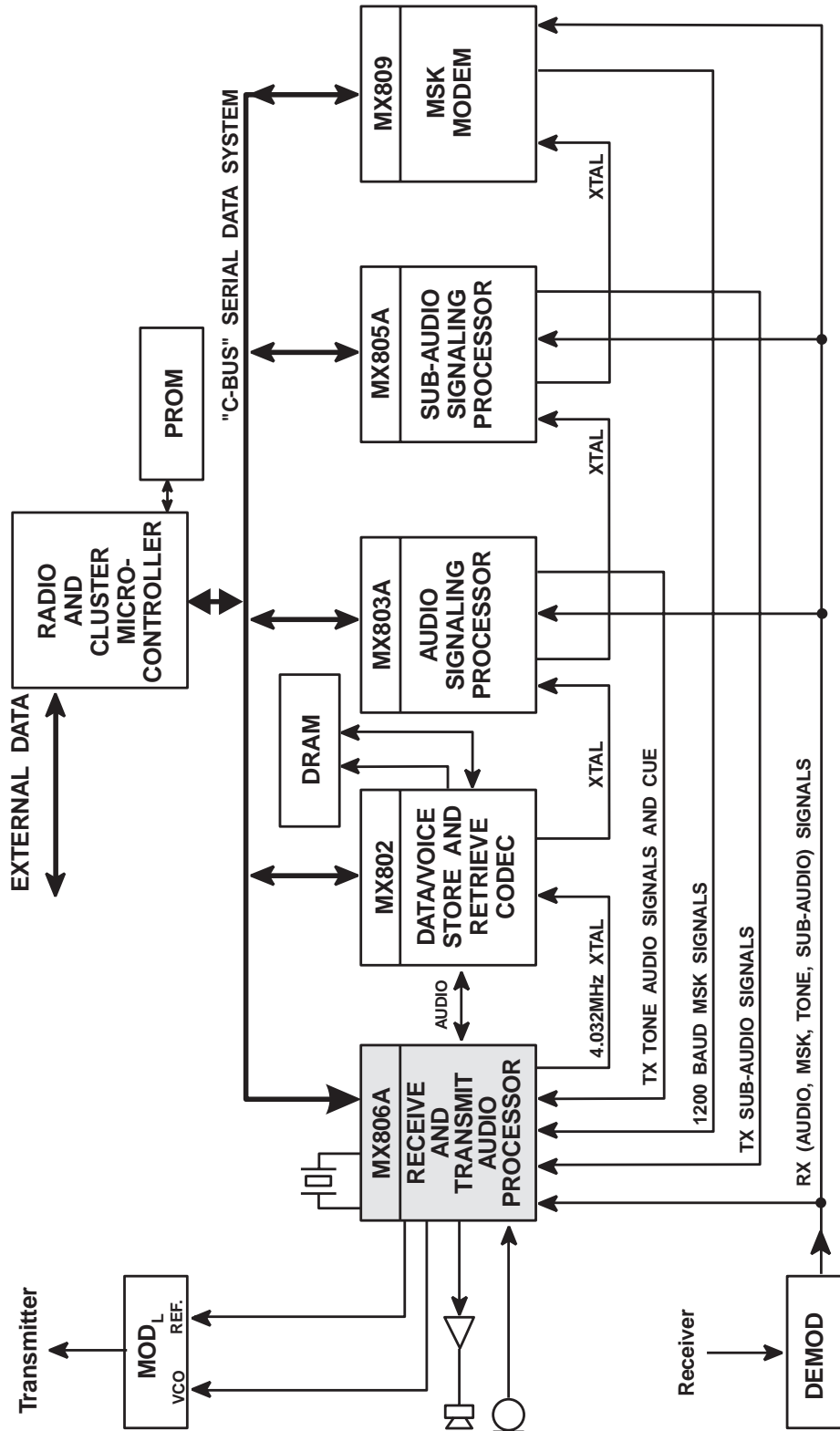
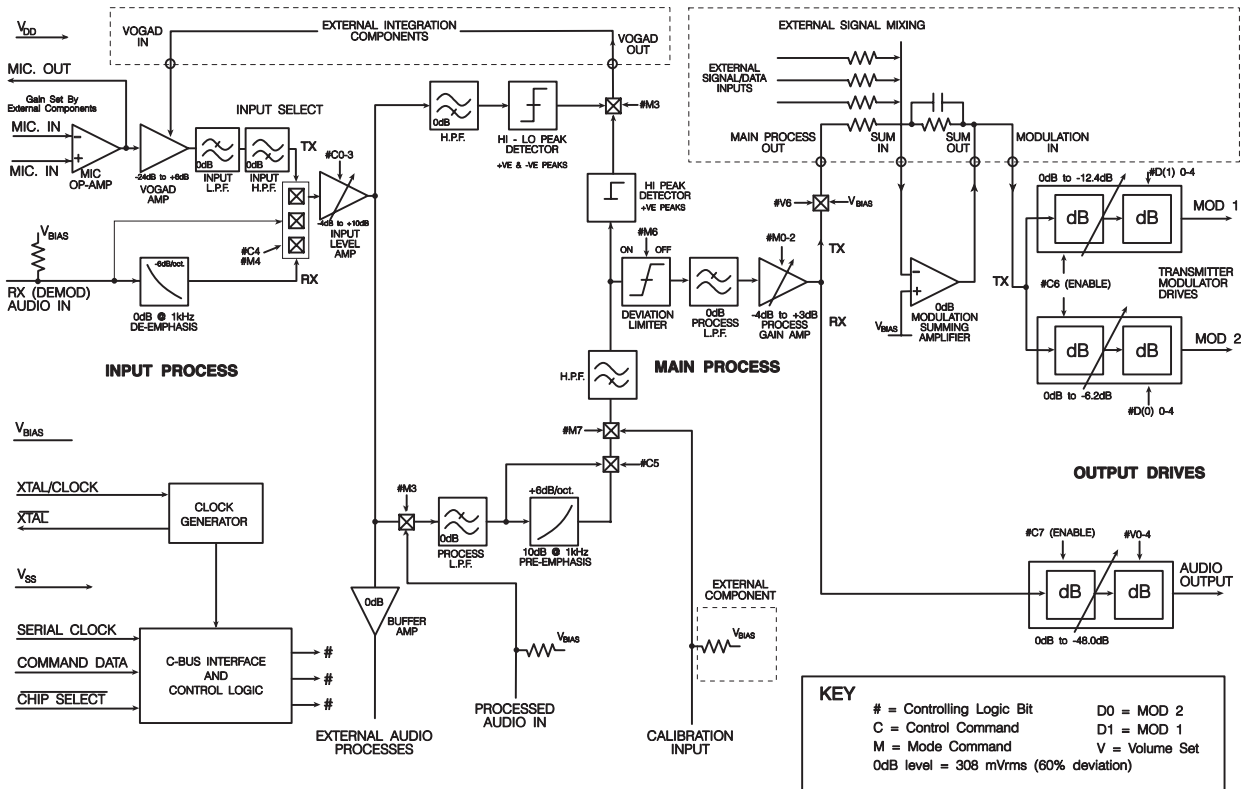

Figure 4 - MX806A Interfaced with Other DBS800 Elements

Figure 4: MX806A Interfaced with Other DBS 800 Elements



MX806A - LMR Audio Processor Explanatory Block Diagram

Reprinted courtesy of MX-COM, INC. (800 638-5577)

Figure 5: LMR Audio Processor Explanatory Block Diagram

5 Controlling Protocol

Control of the functions and levels within the MX806A LMR Audio processor is by a group of Address/Commands and appended data instructions from the system microcontroller. The use of these instructions is detailed in the following paragraphs and tables.

| Command Assignment | HEX | Address/Command Binary | | Command Data | Table |
|--------------------|-----|------------------------|-----|--------------|-------|
| | | MSB | LSB | | |
| General Reset | 01 | 00000001 | | | |
| Control Command | 10 | 00010000 | | 1 byte | 2 |
| Mode Command | 11 | 00010001 | | 1 byte | 3 |
| Mod. Levels Set | 12 | 00010010 | | 2 bytes | 4 |
| Volume Set | 13 | 00010011 | | 1 byte | 5 |

Table 3: C-BUS Address/Commands

In "C-BUS" protocol the MX806A is allocated Address/Command values 10H and 13H. C-BUS Command Mode, Modulation and Volume assignments, and data requirements are given in Table 3 and illustrated in Figure 5.

Commands and Data are only to be loaded in the group configurations detailed since the "C-BUS" interface recognizes the first byte after Chip Select (logic "0") as an Address/Command.

Function or Level control data, which is detailed in Table 4, Table 5, Table 6, and Table 7, is acted upon at the end of the loaded instruction

Upon power-up the value of the “bits” in this device will be random (either “0” or “1”). A General Reset Command (01H) is required. This command is provided to “reset” all devices on the Command “Data line and has the following effect on the MX806A:

| | |
|-------------------------|---------------------------|
| Control Address Command | Loaded as 00 _H |
| Mode Address Command | Loaded as 00 _H |
| Volume Set | Loaded as 00 _H |

5.1.1 Control Command – (Preceded by A/C 10_H)

| Settings | | | | Control Bits |
|----------|----------|----------|----------|--------------------------|
| MSB | | | | |
| 7 | | | | Audio Output (RX) |
| 0 | | | | Disabled |
| 1 | | | | Enabled |
| 6 | | | | Modulation Drives |
| 0 | | | | Disabled |
| 1 | | | | Enabled |
| 5 | | | | Pre-Emphasis |
| 0 | | | | Bypass |
| 1 | | | | Enabled |
| 4 | | | | Input Select |
| 0 | | | | RX In |
| 1 | | | | Mic. In |
| 3 | 2 | 1 | 0 | Input Level Set |
| 0 | 0 | 0 | 0 | Input Amp Disabled |
| 0 | 0 | 0 | 1 | -4.0dB |
| 0 | 0 | 1 | 0 | -3.0dB |
| 0 | 0 | 1 | 1 | -2.0dB |
| 0 | 1 | 0 | 0 | -1.0dB |
| 0 | 1 | 0 | 1 | 0dB |
| 0 | 1 | 1 | 0 | 1.0dB |
| 0 | 1 | 1 | 1 | 2.0dB |
| 1 | 0 | 0 | 0 | 3.0dB |
| 1 | 0 | 0 | 1 | 4.0dB |
| 1 | 0 | 1 | 0 | 5.0dB |
| 1 | 0 | 1 | 1 | 6.0dB |
| 1 | 1 | 0 | 0 | 7.0dB |
| 1 | 1 | 0 | 1 | 8.0dB |
| 1 | 1 | 1 | 0 | 9.0dB |
| 1 | 1 | 1 | 1 | 10.0dB |

Table 4: Control Commands

5.1.2 Mode Command – (Preceded by A/C 11_H)

| Setting | | | Mode Bits |
|----------|----------|----------|--------------------------|
| MSB | | | |
| 7 | | | Drive Source |
| 0 | | | Signals |
| 1 | | | Calibration |
| 6 | | | Deviation Limiter |
| 0 | | | Disabled |
| 1 | | | Enabled |
| 5 | | | VOGAD |
| 0 | | | Disabled |
| 1 | | | Enabled |
| 4 | | | De-Emphasis |
| 0 | | | Enabled |
| 1 | | | Bypassed |
| 3 | | | Signal Select |
| 0 | | | Internal |
| 1 | | | External |
| 2 | 1 | 0 | Process Gain Set |
| 0 | 0 | 0 | -4.0dB |
| 0 | 0 | 1 | -3.0dB |
| 0 | 1 | 0 | -2.0dB |
| 0 | 1 | 1 | -1.0dB |
| 1 | 0 | 0 | 0dB |
| 1 | 0 | 1 | 1.0dB |
| 1 | 1 | 0 | 2.0dB |
| 1 | 1 | 1 | 3.0dB |

Table 5: Mode Commands

5.1.3 Modulator Levels – (Preceded by A/C 12_H)

| Setting | | | | | Modulator Drives |
|---------|---|---|---|---|-----------------------------|
| Byte 1 | | | | | First byte for transmission |
| MSB | | | | | |
| 7 | 6 | 5 | | | |
| 0 | 0 | 0 | | | Must be "0" |
| 4 | 3 | 2 | 1 | 0 | VCO Drive Attenuation |
| 0 | 0 | 0 | 0 | 0 | 12.4dB |
| 0 | 0 | 0 | 0 | 1 | 12.0dB |
| 0 | 0 | 0 | 1 | 0 | 11.6dB |
| 0 | 0 | 0 | 1 | 1 | 11.2dB |
| 0 | 0 | 1 | 0 | 0 | 10.8dB |
| 0 | 0 | 1 | 0 | 1 | 10.4dB |
| 0 | 0 | 1 | 1 | 0 | 10.0dB |
| 0 | 0 | 1 | 1 | 1 | 9.6dB |
| 0 | 1 | 0 | 0 | 0 | 9.2dB |
| 0 | 1 | 0 | 0 | 1 | 8.8dB |
| 0 | 1 | 0 | 1 | 0 | 8.4dB |
| 0 | 1 | 0 | 1 | 1 | 8.0dB |
| 0 | 1 | 1 | 0 | 0 | 7.6dB |
| 0 | 1 | 1 | 0 | 1 | 7.2dB |
| 0 | 1 | 1 | 1 | 0 | 6.8dB |
| 0 | 1 | 1 | 1 | 1 | 6.4dB |
| 1 | 0 | 0 | 0 | 0 | 6.0dB |
| 1 | 0 | 0 | 0 | 1 | 5.6dB |
| 1 | 0 | 0 | 1 | 0 | 5.2dB |
| 1 | 0 | 0 | 1 | 1 | 4.8dB |
| 1 | 0 | 1 | 0 | 0 | 4.4dB |
| 1 | 0 | 1 | 0 | 1 | 4.0dB |
| 1 | 0 | 1 | 1 | 0 | 3.6dB |
| 1 | 0 | 1 | 1 | 1 | 3.2dB |
| 1 | 1 | 0 | 0 | 0 | 2.8dB |
| 1 | 1 | 0 | 0 | 1 | 2.4dB |
| 1 | 1 | 0 | 1 | 0 | 2.0dB |
| 1 | 1 | 0 | 1 | 1 | 1.6dB |
| 1 | 1 | 1 | 0 | 0 | 1.2dB |
| 1 | 1 | 1 | 0 | 1 | 0.8dB |
| 1 | 1 | 1 | 1 | 0 | 0.4dB |
| 1 | 1 | 1 | 1 | 1 | 0dB |

| Setting | | | | | Modulator Drives |
|---------|---|---|---|---|----------------------------|
| Byte 0 | | | | | Last byte for transmission |
| MSB | | | | | |
| 7 | 6 | 5 | | | |
| 0 | 0 | 0 | | | Must be "0" |
| 4 | 3 | 2 | 1 | 0 | VCO Drive Attenuation |
| 0 | 0 | 0 | 0 | 0 | 6.2dB |
| 0 | 0 | 0 | 0 | 1 | 6.0dB |
| 0 | 0 | 0 | 1 | 0 | 5.8dB |
| 0 | 0 | 0 | 1 | 1 | 5.6dB |
| 0 | 0 | 1 | 0 | 0 | 5.4dB |
| 0 | 0 | 1 | 0 | 1 | 5.2dB |
| 0 | 0 | 1 | 1 | 0 | 5.0dB |
| 0 | 0 | 1 | 1 | 1 | 4.8dB |
| 0 | 1 | 0 | 0 | 0 | 4.6dB |
| 0 | 1 | 0 | 0 | 1 | 4.4dB |
| 0 | 1 | 0 | 1 | 0 | 4.2dB |
| 0 | 1 | 0 | 1 | 1 | 4.0dB |
| 0 | 1 | 1 | 0 | 0 | 3.8dB |
| 0 | 1 | 1 | 0 | 1 | 3.6dB |
| 0 | 1 | 1 | 1 | 0 | 3.4dB |
| 0 | 1 | 1 | 1 | 1 | 3.2dB |
| 1 | 0 | 0 | 0 | 0 | 3.0dB |
| 1 | 0 | 0 | 0 | 1 | 2.8dB |
| 1 | 0 | 0 | 1 | 0 | 2.6dB |
| 1 | 0 | 0 | 1 | 1 | 2.4dB |
| 1 | 0 | 1 | 0 | 0 | 2.2dB |
| 1 | 0 | 1 | 0 | 1 | 2.0dB |
| 1 | 0 | 1 | 1 | 0 | 1.8dB |
| 1 | 0 | 1 | 1 | 1 | 1.6dB |
| 1 | 1 | 0 | 0 | 0 | 1.4dB |
| 1 | 1 | 0 | 0 | 1 | 1.2dB |
| 1 | 1 | 0 | 1 | 0 | 1.0dB |
| 1 | 1 | 0 | 1 | 1 | 0.8dB |
| 1 | 1 | 1 | 0 | 0 | 0.6dB |
| 1 | 1 | 1 | 0 | 1 | 0.4dB |
| 1 | 1 | 1 | 1 | 0 | 0.2dB |
| 1 | 1 | 1 | 1 | 1 | 0dB |

Table 6: Modulator Drive Levels

5.1.4 Volume Set – (Preceded by A/C 13H)

| Setting | | | | | Volume Set |
|---------|---|---|---|---|-----------------------|
| MSB | | | | | |
| 7 | | | | 5 | Main Process Out |
| 0 | | | | 0 | Enabled |
| 0 | | | | 1 | Biased |
| 5 | | | | | Powersave |
| 0 | | | | | Chip Enabled |
| 1 | | | | | Powersaved |
| 4 | 3 | 2 | 1 | 0 | VCO Drive Attenuation |
| 0 | 0 | 0 | 0 | 0 | OFF |
| 0 | 0 | 0 | 0 | 1 | 48.0dB |
| 0 | 0 | 0 | 1 | 0 | 46.4dB |
| 0 | 0 | 0 | 1 | 1 | 44.8dB |
| 0 | 0 | 1 | 0 | 0 | 43.2dB |
| 0 | 0 | 1 | 0 | 1 | 41.6dB |
| 0 | 0 | 1 | 1 | 0 | 40.0dB |
| 0 | 0 | 1 | 1 | 1 | 38.4dB |
| 0 | 1 | 0 | 0 | 0 | 36.8dB |
| 0 | 1 | 0 | 0 | 1 | 35.2dB |
| 0 | 1 | 0 | 1 | 0 | 33.6dB |
| 0 | 1 | 0 | 1 | 1 | 32.0dB |
| 0 | 1 | 1 | 0 | 0 | 30.4dB |
| 0 | 1 | 1 | 0 | 1 | 28.8dB |
| 0 | 1 | 1 | 1 | 0 | 27.2dB |
| 0 | 1 | 1 | 1 | 1 | 25.6dB |
| 1 | 0 | 0 | 0 | 0 | 24.0dB |
| 1 | 0 | 0 | 0 | 1 | 22.4dB |
| 1 | 0 | 0 | 1 | 0 | 20.8dB |
| 1 | 0 | 0 | 1 | 1 | 19.2dB |
| 1 | 0 | 1 | 0 | 0 | 17.6dB |
| 1 | 0 | 1 | 0 | 1 | 16.0dB |
| 1 | 0 | 1 | 1 | 0 | 14.4dB |
| 1 | 0 | 1 | 1 | 1 | 12.8dB |
| 1 | 1 | 0 | 0 | 0 | 11.2dB |
| 1 | 1 | 0 | 0 | 1 | 9.6dB |
| 1 | 1 | 0 | 1 | 0 | 8.0dB |
| 1 | 1 | 0 | 1 | 1 | 6.4dB |
| 1 | 1 | 1 | 0 | 0 | 4.8dB |
| 1 | 1 | 1 | 0 | 1 | 3.2dB |
| 1 | 1 | 1 | 1 | 0 | 1.6dB |
| 1 | 1 | 1 | 1 | 1 | 0dB |

Table 7: Volume Set

Notes:

1. Command Loading: Address/Commands and data bytes must be loaded in accordance with the information given in Figure 7.
2. The powersave function is enabled by bit 5 of the Volume Set Command (Table 7). During Powersave all internal elements except the clock Generator and "C-BUS" interface are off. The Mic Op-Amp and output Drive stage outputs are connected to V_{SS} .
3. Modulator Drives are controlled separately, but the whole two-byte modulator Drive command must be loaded for each requirement adjustment.
4. $\overline{\text{Chip Select}}$ must be held at a logic "1" for the period " t_{CSOFF} " between transactions.

6 Application Notes

To assist in rapid setting, this quick-reference list should be used with Figure 5.

| | |
|-------------------------|------------------------------------|
| Control | A/C = 10_H |
| 7 | Audio Out (RX) Enable |
| 6 | Modulator Drive Enable |
| 5 | Pre-Emphasis Select |
| 4 | Input Select (RX/TX) |
| 3-0 | Input Level Set (-4dB to 10dB) |
| Mode | A/C = 11_H |
| 7 | Drive Source |
| 6 | Derivation Limiter Enable |
| 5 | VOGAD Enable |
| 4 | De-emphasis Enable |
| 3 | Signal Select |
| 2-0 | Process Gain Set |
| Modulator Levels | A/C = 12_H |
| Byte 1 | |
| 7-5 | "0" |
| 4-0 | Mod 1 Attenuation (0 to 12.4dB) |
| Byte 2 | |
| 7-5 | "0" |
| 4-0 | Mod 2 Attenuation (0 to 6.2dB) |
| Volume Set | A/C = 13_H |
| 7-6 | "0" |
| 5 | Powersave |
| 4-0 | Volume Set Attenuation (0 to 48dB) |

Table 8: Quick Reference List

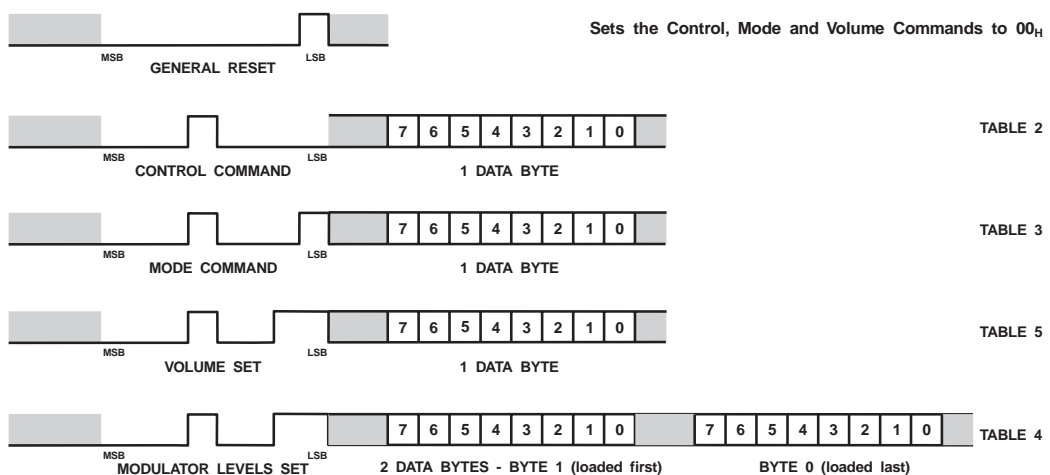

Figure 6: Examples of Command Data Configurations

7 Performance Specifications

7.1 Electrical Specifications

7.1.1 Absolute Maximum Limits

Exceeding these maximum ratings can result in damage to the device.

| General | Notes | Min. | Typ. | Max. | Units |
|---|-------|------|------|----------------|---|
| Supply ($V_{DD}-V_{SS}$) | | -0.3 | | 7.0 | V |
| Voltage on any pin to V_{SS} | | -0.3 | | $V_{DD} + 0.3$ | V |
| Current | | | | | |
| V_{DD} | | -30 | | 30 | mA |
| V_{SS} | | -30 | | 30 | mA |
| Any other pin | | -20 | | 20 | mA |
| P / DW / LH Packages | | | | | |
| Total allowable Power dissipation at $T_{AMB} = 25^{\circ}\text{C}$ | | | | 800 | mW |
| Derating above 25°C | | | 10 | | mW/ $^{\circ}\text{C}$ above 25°C |
| Operating Temperature | | -40 | | 85 | $^{\circ}\text{C}$ |
| Storage Temperature | | -55 | | 125 | $^{\circ}\text{C}$ |

Table 9: Absolute Maximum Ratings

7.1.2 Operating Limits

Correct Operation of the device outside these limits is not implied.

| | Notes | Min. | Typ. | Max. | Units |
|----------------------------|-------|------|------|------|--------------------|
| Supply ($V_{DD}-V_{SS}$) | | 4.5 | 5.0 | 5.5 | V |
| Operating Temperature | | -40 | | 85 | $^{\circ}\text{C}$ |
| Xtal Frequency | | | 4.0 | | MHz |

Table 10: Operating Limits

7.1.3 Operating Characteristics

For the following conditions unless otherwise specified.

$V_{DD} = 5.0V$ @ $T_{AMB} = 25^{\circ}C$

Xtal/Clock Frequency = 4.0MHz, Audio Level 0dB ref. = 308mV_{RMS} @ 1kHz (60% deviation, FM)

| | Notes | Min. | Typ. | Max. | Units |
|------------------------------------|---------|------|------|------|-------------------|
| Static Values | | | | | |
| Supply Current | | | | | |
| All Elements Enabled | | | 8.0 | 15.0 | mA |
| Maximum Powersave | | | 0.7 | 1.5 | mA |
| "C-BUS" Interface | | | | | |
| Input Logic "1" | | 3.5 | | | V |
| Input Logic "0" | | | | 1.5 | V |
| Input Current | | -1.0 | | 1.0 | μA |
| Input Capacitance | | | | 7.5 | pF |
| Overall Performance | | | | | |
| Microphone Input Level | 1, 2 | | 25 | | mV _{RMS} |
| Discriminator Input Level | 2, 3 | 154 | | 308 | mV _{RMS} |
| Output Drive Level | | | | | |
| 60% Deviation | 2, 4 | 291 | 308 | 326 | mV _{RMS} |
| 100% Deviation | 2, 4, 5 | | 1440 | | MV _{P-P} |
| Passband | 6 | 297 | | 3000 | Hz |
| Passband Ripple | 7 | -2 | | 0.5 | dB |
| Stopband Attenuation | 6, 8 | | | | |
| @ 150Hz | | 10 | 12 | | dB |
| @ 3400Hz | | | 2 | | dB |
| @ 6000Hz | | 30 | 36 | | dB |
| @ 8000Hz to 20,000Hz | | | 60 | | dB |
| Signal Path Noise | | | | | |
| TX | | | -50 | | dBp |
| TX | 9 | | -45 | | dB |
| RX | | | -60 | | dB |
| RX | 9 | | -55 | | dB |
| Total Harmonic Distortion | | | | | |
| RX or TX, 60% Deviation | | | 1.0 | | % |
| Circuit Elements – Figure 5 | | | | | |
| Mic. Amp or Mod. Summation Amp | | | | | |
| Open Loop Gain | | | 50.0 | | dB |
| Bandwidth | | 20.0 | | | kHz |
| Input Impedance | | 10.0 | | | MΩ |
| Output Impedance | | | | | |
| Open Loop | | | 6.0 | | kΩ |
| Closed Loop | | | 600 | | Ω |
| De-emphasis | | | | | |
| Slope | | | -6.0 | | dB/octave |
| Gain | | | 0 | | dB |
| Input Impedance | | | 1 | | MΩ |

| | Notes | Min. | Typ. | Max. | Units |
|--|-------|------|------|------|-------------------|
| Voltage Controlled Gain Amp (VOGAD) | | | | | |
| Gain | | | | | |
| Non-Compression | 2 | | 6.0 | | dB |
| Full-Compression | | | -24 | | dB |
| Input Impedance | | 10.0 | | | M Ω |
| VOGAD Peak Detectors | | | | | |
| Output Impedance | | | | | |
| Logic "1" (Compress) | | | 1 | | k Ω |
| Logic "0" | | | 10 | | M Ω |
| Hi/Lo Peak Detector Threshold | 10 | | 1300 | | mV _{P-P} |
| Hi Peak Detector Threshold | 10 | | 650 | | mV + ve pk |
| Input (Low + Highpass) Filter | | | | | |
| Gain @ 1.0kHz | | -1.0 | | 1.0 | dB |
| Input Level Amp | | | | | |
| Gain Range | | | 0 | | dB |
| Overall Tolerance | | -1.0 | | 1.0 | dB |
| Step Size | | 0.75 | 1.0 | 1.25 | dB |
| External Audio Buffer | | | | | |
| Gain | | -0.1 | 0 | 0.1 | dB |
| Pre-emphasis (Main Process and VOGAD) | | | | | |
| Slope | | | 6.0 | | dB/octave |
| Gain @ 1.0kHz | | | 10.0 | | dB |
| Process Highpass Filter | | | | | |
| Gain @ 1.0kHz | | -0.1 | 0 | 0.1 | dB |
| Deviation Limiter | | | | | |
| Threshold | | 708 | 1300 | 1413 | mV _{RMS} |
| Gain | | -0.5 | | 0.5 | dB |
| Process Lowpass Filter | | | | | |
| Gain @ 1.0kHz | | -0.1 | 0 | 0.1 | dB |
| Process Gain Amp | | | | | |
| Gain Range | | -4.0 | | 3.0 | dB |
| Overall Tolerance | | -0.5 | | 0.5 | dB |
| Step Size | | 0.75 | 1.0 | 1.25 | dB |
| Output Impedance | | | 600 | | Ω |
| Transmitter Modulator Drives | | | | | |
| Input Impedance | | | 15.0 | | k Ω |
| Mod. 1 Attenuator | | | | | |
| Attenuation Range | | 0 | | 12.4 | dB |
| Overall Tolerance | | -1 | | 1 | dB |
| Step Size | | 0.2 | 0.4 | 0.6 | dB |
| Output Impedance | | | 600 | | Ω |
| Mod. 2 Attenuator | | | | | |
| Attenuation Range | | 0 | | 6.2 | dB |
| Overall Tolerance | | -0.5 | | 0.5 | dB |
| Step Size | | 0.1 | 0.2 | 0.3 | dB |
| Output Impedance | | | 600 | | Ω |

| | Notes | Min. | Typ. | Max. | Units |
|----------------------------|-------|------|------|------|------------|
| Audio Output Attenuator | | | | | |
| Attenuation Range | | 0 | | 48.0 | dB |
| Overall Tolerance | | -1.0 | | 1.0 | dB |
| Step Size | | 1.1 | 1.6 | 2.1 | dB |
| Output Impedance | | | 600 | | Ω |
| Miscellaneous Impedances | | | | | |
| Processed Audio Input | | | 500 | | k Ω |
| Calibration Input | | | 500 | | k Ω |
| External Process Out | | | 100 | | Ω |
| RX with De-emphasis Bypass | | | 25.0 | | k Ω |

Table 11: Operating Characteristics

Operating Characteristics Notes:

1. Producing an output of 0dB with the Mic. Op-Amp set to 6dB (as shown in Figure 2) and the Modulator Drives set to 0dB.
2. With Output Drives set to 0dB and the system calibrated as described in the Application Notes.
3. Input level range for 0dB output, by adjustment of the Input Level Amp.
4. It is recommended that these output levels will produce 60% or 100% deviation in the transmitter.
5. With the microphone input level 20dB above the level required to produce 0dB at the Output Drives.
6. Between Microphone or RX inputs to Modulator or Audio Outputs.
7. Deviation from the ideal overall response including the pre- or de-emphasis slope.
8. Excluding the effect of pre- or de-emphasis slope.
9. In a 30kHz bandwidth.
10. Using pre-emphasis in the TX path.

7.1.4 Timing

Timing Parameters for two-way communications between the μ C and the MX805A on the C-BUS are shown in Table 12.

| C-BUS Timing | | Min. | Typ. | Max. | Units |
|--------------|---|------|------|------|---------|
| t_{CSE} | Chip Select Low to First Serial Clock Rising Edge | 2.0 | | | μ S |
| t_{CHS} | Last Serial Clock Rising Edge to Chip Select High | 4.0 | | | μ S |
| t_{CSOFF} | Chip Select High time between transactions | 2.0 | | | μ S |
| t_{NXT} | Inter-Byte Time | 4.0 | | | μ S |
| t_{CK} | Serial Clock Period | 2.0 | | | μ S |

Table 12: Timing Information

Notes:

1. Command Data is transmitted to the peripheral MSB (bit 7) first, LSB (bit 0) last. Reply Data is read from the MX805A MXB (bit 7) first, LSB (bit 0) last.
2. Data is clocked into the MX805A and into the microcontroller on the rising Serial Clock edge.
3. Loaded data instructions are acted upon at the end of each individual, loaded byte.
4. To allow for differing microcontroller serial interface formats, the MX806A will work with either polarity Serial Clock pulses.

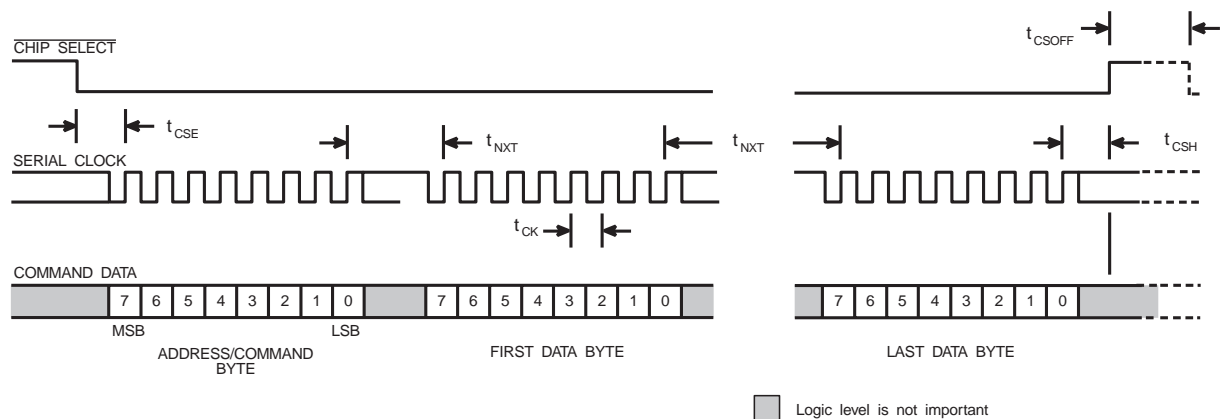

Figure 7: C-BUS Timing Information

7.2 Packages

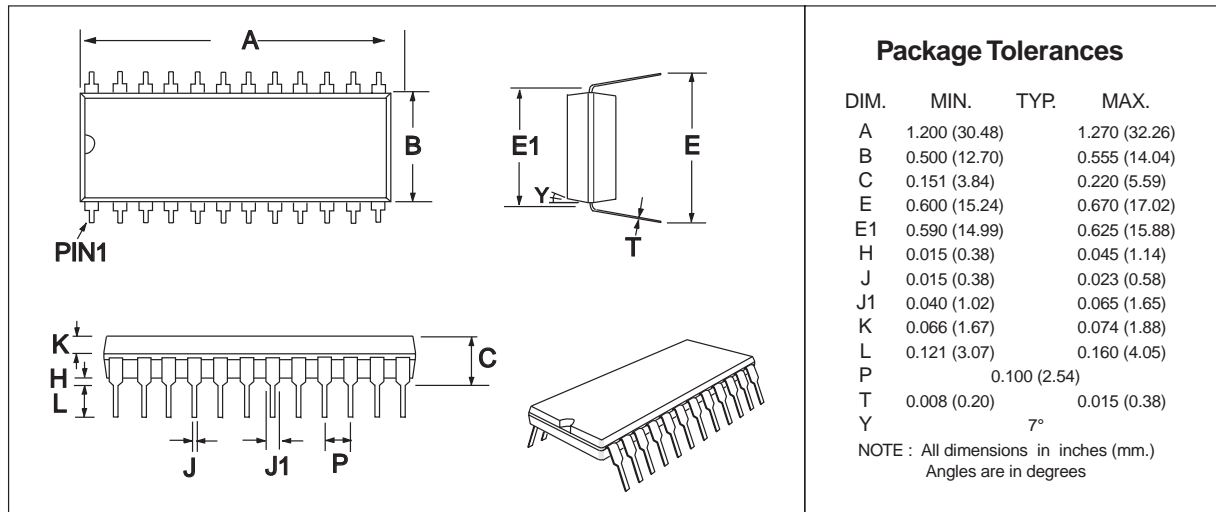

Figure 8: 24-pin PDIP Mechanical Outline: Order as part no. MX806AP

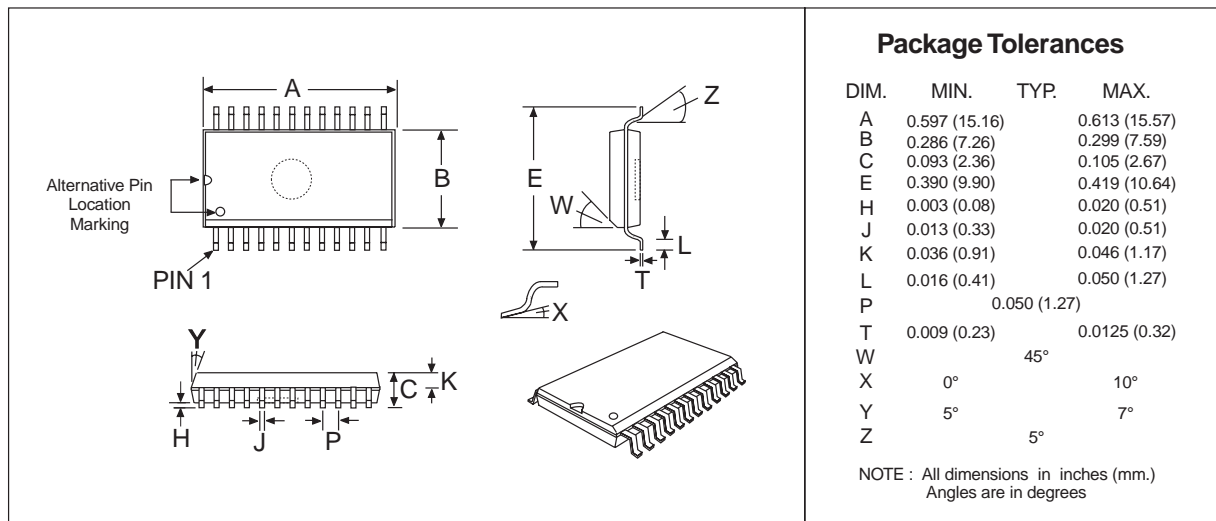

Figure 9: 24-pin SOIC Mechanical Outline: Order as part no. MX806ADW

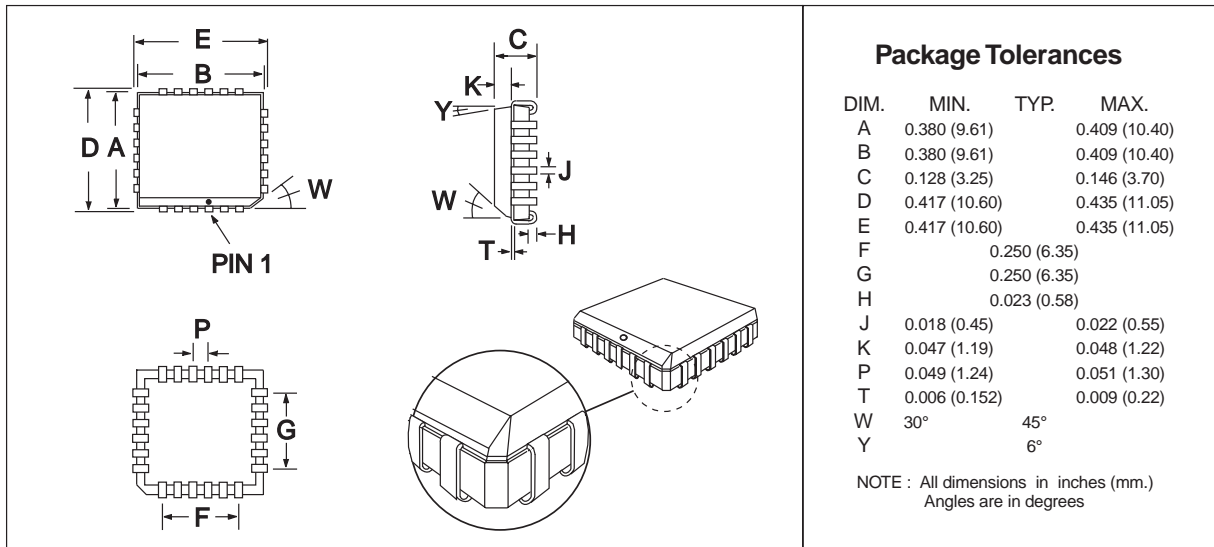

Figure 10: 24-pin PLCC Mechanical Outline: *Order as part no. MX806ALH*