

MX-COM, INC. Mixed Signal ICs

DATA BULLETIN

MX809 1200bps MSK Modem

PRELIMINARY INFORMATION

Features

- Half-Duplex 1200bps MSK Modem operating under C-BUS control
- Software Selectable Checksum Generation and Error Checking in accordance with MPT1327
- Low Power Operation
- Member of DBS800 Family (C-BUS Compatible)

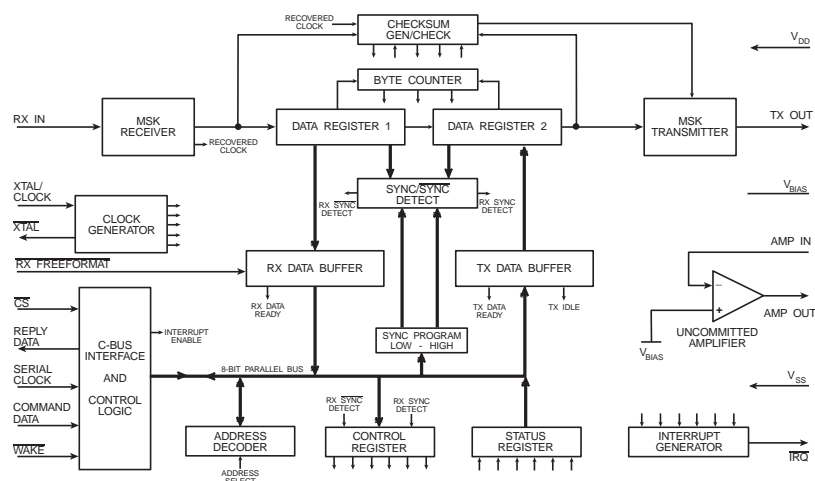

The MX809 is an intelligent, half-duplex 1200-baud MSK Modem, which operates under C-BUS control. This modem provides software selectable checksum generation and error checking in accordance with MPT1327.

In TX Mode the MX809 will:

1. a) Accept from the host and transmit 8-bit bytes of data as instructed (preamble, sync, address, and data), or
 b) Internally calculate and inset a 2 byte checksum based on the preceding 6 bytes of data, or
 c) Disable the internal checksum generator and continuously transmit the data supplied.
2. Transmit 1 hang-bit and go to TX idle when all loaded data bytes have been transmitted.

In RX Mode the MX809 will:

1. Detect and carry out bit synchronization within 16 bits.
2. a) Search and detect the user-programmed Sync (or its opposite logic sense) Word and carry out frame synchronization. Data will then be output in 8-bit bytes via the RX Data Buffer.
 b) Use the received checksum to calculate the presence of any errors, setting the Status Register accordingly.
3. Make the incoming data directly available via the RX Data Buffer (RX Freeformat), overriding the synchronization requirements.

RX input timing is achieved by recovering an RX clock from the incoming data stream. Output tones are timed to the internally generated TX clock. Filter, register clocks, and transmit MSK tone frequencies are derived internally from the external Xtal or clock pulse input.

A 4.032MHz Xtal or clock input is required for compliance with the MPT1327 Signaling Specification. Note: All information contained in this data bulletin is specified using a 4.032MHz Xtal, 1200bps baud rate, with Mark and Space frequencies of 1200Hz and 1800Hz. The MX809 has a non-committed amplifier on-chip for general applications in the DBS 800 series.

The MX809 may be used with a 5.0V power supply and is available in the following packages: 24-pin PLCC (MX809LH), and 24-pin CERDIP (MX809J).

Contents

Section	Page
1 Block Diagram.....	3
2 Signal List.....	4
3 External Components.....	6
4 General Description.....	7
5 Controlling Protocol.....	7
5.1 Address/Commands.....	7
5.2 Address Select.....	8
5.3 Write to Control Register.....	9
5.4 RX Data buffer -- "Read RX Data Buffer".....	9
5.5 TX Data Buffer -- "Write to TX Data Buffer".....	10
5.6 SYNC Program -- "Write to SYNC Program".....	10
5.7 Read Status Register.....	10
5.8 Interrupt Request.....	11
5.9 General Reset.....	11
6 Application.....	12
6.1 Checksum Generation and Checking.....	12
6.1.1 Generation.....	12
6.1.2 Checking.....	12
6.2 Modem Performance.....	12
6.3 Modem Timing Information.....	13
6.4 TX Timing.....	14
6.4.1 TX More Than One Message, SYNC Before Every Message, TX Checksum Enabled.....	14
6.4.2 TX More Than One Message, TX Checksum Not Enabled.....	14
6.4.3 TX One Message, TX Checksum Enabled.....	15
6.4.4 TX One Message, TX Checksum Not Enabled.....	15
6.5 RX Timing.....	16
6.5.1 RX SYNC / SYNC Required Before Every Message, Rx Checksum Not Enabled.....	16
6.5.2 RX Additional Data Follows Initial Address (6 Data & 2 Checksum Bytes) Data, RX checksum Enabled.....	16
7 Performance Specifications.....	17
7.1 Electrical Specifications.....	17
7.1.1 Absolute Maximum Limits.....	17
7.1.2 Operating Limits.....	17
7.1.3 Operating Characteristics.....	18
7.1.4 Timing.....	20
7.2 Packages.....	21

MXCOM, Inc. reserves the right to change specifications at any time without notice.

1 Block Diagram

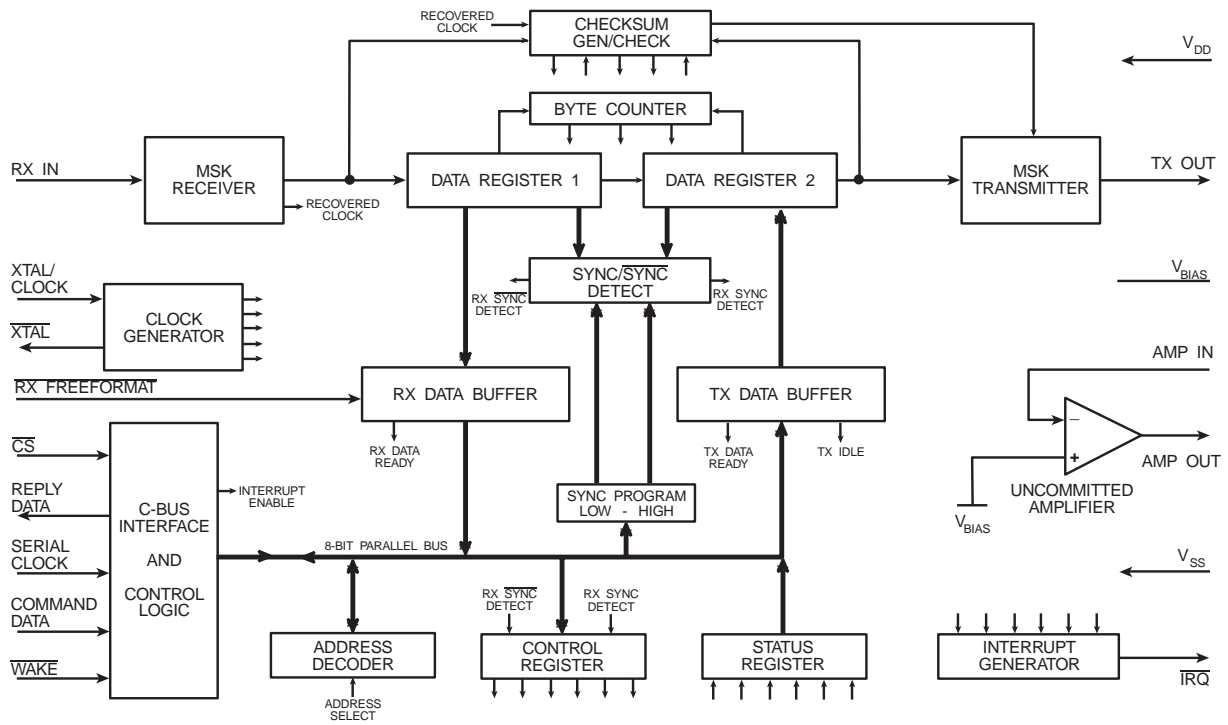

Figure 1: Block Diagram

2 Signal List

Pin	Signal	Description
1	$\overline{\text{Xtal}}$	This is the output of the on-chip clock oscillator. External components are required at this output when a Xtal is used. See Figure 2. Inset
2	Xtal/Clock	This is the input to the on-chip clock oscillator inverter. A Xtal or externally derived clock should be connected here. See Figure 2. Inset
3	$\overline{\text{IRQ}}$	The output of this pin indicates an interrupt condition to the microcontroller by going to a logic "0". This is a "wire-or-able" output that enables the connection of up to 8 peripherals to 1 interrupt port on the microcontroller. This pin is an open-drain output, and therefore has a low impedance pulldown to logic "0" when active and a high impedance when inactive. The conditions that cause interrupts are indicted in the Status Register and are shown in Table 2. The system $\overline{\text{IRQ}}$ line requires a pull-up resistor to V_{DD} .
4	N/C	
5	N/C	
6	$\overline{\text{RXFreeformat}}$	When this input is logic "0" in the RX Mode, it allows received data to be read from the RX Data Buffer via the Reply Data line without having to achieve byte synchronization (SYNC/ $\overline{\text{SYNC}}$) first. Data will continue to be available after this input goes to a logic "1" until either a SYNC or $\overline{\text{SYNC}}$ Prime Bit is set or the modem is set to TX Mode. When held at a logic "1" the modem operates normally. This pin has an internal $1M\Omega$ pull-up resistor. Note: If this input is held at a logic "0" in the TX Mode, the RX Data Ready bit in the Status Register may occasionally be set, but not cause an interrupt. If this input is a logic "0" when going into the RX Mode, and RX Data Ready interrupt may be generated immediately (in this case the first byte of RX data should be ignored).
7	V_{BIAS}	The internal circuitry bias line, this is held at $V_{DD}/2$. This pin must be decoupled to V_{SS} by capacitor C3. See Figure 2.
8	Amp In	The inverting input to the on-chip uncommitted amplifier.
9	Amp Out	The output of the on-chip uncommitted amplifier.
10	RX In	This is the 1200 baud, 1200Hz/1800Hz received MSK signal input. The input signal to this pin must be AC coupled via capacitor C4. See Figure 2.
11	N/C	
12	V_{SS}	Negative Supply (GND)
13	TX Out	This is the 1200 baud, 1200Hz/1800Hz MSK TX output. When not transmitting data the output impedance of this pin is high. On power-up this output can be any level. A General Reset command is required to ensure that this output attains V_{BIAS} initially.
14	N/C	
15	N/C	
16	N/C	
17	Reply Data	This is the C-BUS serial data output to the microcontroller. The transmission of Reply Data bytes is synchronized to the Serial Clock under the $\overline{\text{CS}}$ input. This 3-state output is held high impedance when not sending data to the microcontroller. See Section 6 and Section 7.1.4.
18	N/C	
19	$\overline{\text{CS}}$	Chip Select. This is the 'C-BUS' data loading control function. This input is provided by the microcontroller. Data transfer sequences are initiated, completed or aborted by the $\overline{\text{CS}}$ signal. See Section 6 and Section 7.1.4.
20	Command Data	This is the 'C-BUS' serial data input from the microcontroller. Data is loaded to this device in 8-bit bytes, MSB (bit 7) first and LSB (bit 0) last, synchronized to the Serial Clock. See Section 6 and Section 7.1.4.

Pin	Signal	Description
21	Serial Clock	This is the 'C-BUS' serial Clock input. This clock, produced by the microcontroller, is used for transfer timing of commands and data to and from the MSK Modem. See Section 6 and Section 7.1.4.
22	Address Select	This pin enables two MX809s to be used on the same C-BUS, providing full-duplex operation. When at a logic "1" Address/Command bytes (with the exception of a General Reset) must have bit 3 set to a logic "1" to address this device. See Table 5 and Table 6.
23	$\overline{\text{Wake}}$	This input can be used to reactivate the MX809 from Powersave. The device will be in Powersave when both this pin and bit 2 of the Control Register are set to logic "1". Recovery from Powersave is achieved by putting either the $\overline{\text{Wake}}$ pin or the Powersave bit in the Control Register to logic "0". This allows MX809 activation by the microcontroller or an external signal, such as R.S.S.I. or Carrier Detect. See Table 3.
24	V _{DD}	Positive supply. A single +5.0V power supply is required. Levels and voltages within the MSK Modem are dependent upon this supply.

Table 1: Signal List

TX Idle	RX Data Ready	TX Data Ready
RX SYNC Detect		RX Sync Detect
Interrupt outputs can be disabled by bit 3 of the Control Register		

Table 2: $\overline{\text{IRQ}}$ Conditions

Powersave (CR bit 2)	$\overline{\text{Wake}}$	MX809 Condition
1	1	Powersave
0	1	Enabled
1	0	Enabled
0	0	Enabled

Table 3: $\overline{\text{Wake}}$ and Powersave Conditions

3 External Components

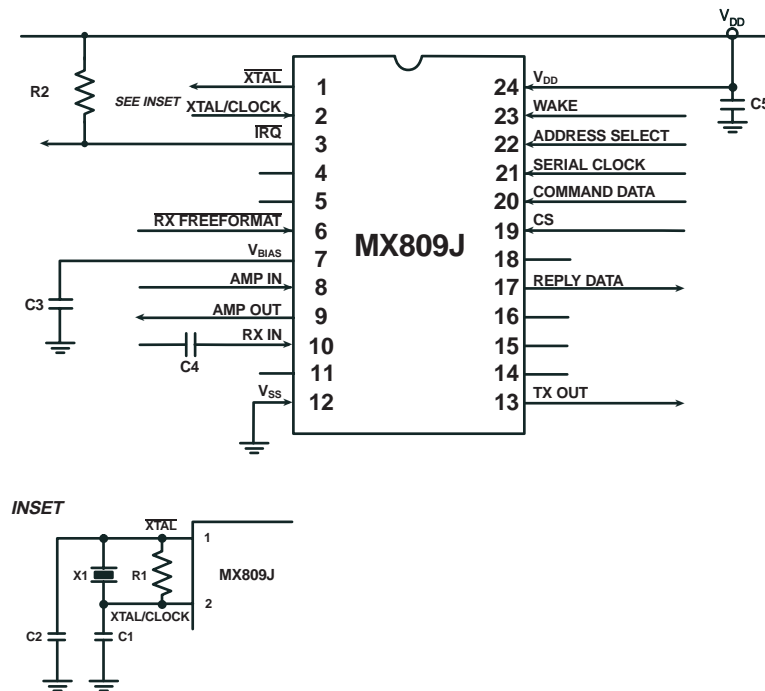

Figure 2: Recommended External Components

Component	Notes	Value	Tolerance
R1		1.0M Ω	$\pm 10\%$
R2		22.0K Ω	$\pm 10\%$
C1	1	33pF	$\pm 20\%$
C2	1	33pF	$\pm 20\%$
C3		1.0 μ F	$\pm 20\%$
C4		0.1 μ F	$\pm 20\%$
C5		1.0 μ F	$\pm 20\%$
X1	1	4.032MHz	

Table 4: Recommended External Components

Recommended External Component Notes:

1. Xtal circuit capacitors C1 (CD) and C2 (CG) shown in Inset 2 are recommended in accordance with MX-COM's Crystal Oscillator Application Note.

4 General Description

The MX809 is an intelligent, half-duplex 1200-baud MSK Modem, which operates under C-BUS control. This modem provides software selectable checksum generation and error checking in accordance with MPT1327.

In TX Mode the MX809 will:

1. a) Accept from the host and transmit 8-bit bytes of data as instructed (preamble, sync, address, and data), or
 - b) Internally calculate and inset a 2 byte checksum based on the preceding 6 bytes of data, or
 - c) Disable the internal checksum generator and continuously transmit the data supplied.
2. Transmit 1 hang-bit and go to TX idle when all loaded data bytes have been transmitted.

In RX Mode the MX809 will:

1. Detect and carry out bit synchronization within 16 bits.
2. a) Search and detect the user-programmed Sync (or its opposite logic sense) Word and carry out frame synchronization. Data will then be output in 8-bit bytes via the RX Data Buffer.
 - b) Use the received checksum to calculate the presence of any errors, setting the Status Register accordingly.
3. Make the incoming data directly available via the RX Data Buffer (RX Freeformat), overriding the synchronization requirements.

RX input timing is achieved by recovering an RX clock from the incoming data stream. Output tones are timed to the internally generated TX clock. Filter, register clocks, and transmit MSK tone frequencies are derived internally from the external Xtal or clock pulse input.

A 4.032MHz Xtal or clock input is required for compliance with the MPT1327 Signaling Specification. Note: All information contained in this data bulletin is specified using a 4.032MHz Xtal, 1200bps baud rate, with Mark and Space frequencies of 1200Hz and 1800Hz. The MX809 has a non-committed amplifier on-chip for general applications in the DBS 800 series.

5 Controlling Protocol

Control of the functions within the MX809 MSK Modem is by a group of Address/Commands and appended data instructions from the system microcontroller. Two separate MSK Modems can be addressed. The use of these A/Cs is detailed in the following paragraphs and tables.

Command Assignment		Address/Command Binary		Command Data
	HEX	MSB LSB		
General Reset	01	00000001		Control Register bits set to logic "0"
Write to Control Register	40	01000000	+	1 byte instruction to Control Register
Read Status Register	41	01000001	+	1 byte reply from Status Register
Read RX Data Buffer	42	01000010	+	1 byte of data from RX Data Buffer
Write to TX Data Buffer	43	01000011	+	1 byte of data to TX Data Buffer
Write to SYNC Program	44	01000100	+	2 bytes of SYNC Word to SYNC Program Register

Table 5: Modem No. 1 C-BUS Address/Commands – (Address Select input at a logic "0")

5.1 Address/Commands

Instructions and data transactions to and from the MX809 consist of an Address/Command (A/C) byte followed by either further instructions or data, or a Status or RX Data Reply.

Control and configuration is by writing instructions from the microcontroller to the Control Register [40_H (48_H)].

Reporting of the MX809 configuration is by reading the Status Register [41_H (49_H)]. Instructions and data are transferred via C-BUS in accordance with the timing information given in Figure 11.

Data to be transmitted as MSK is sent to the TX Data Buffer via the Command Data line. Received data is read from the RX Data buffer via the Reply Data line.

Instructions and data transactions to and from this device are preceded by the relevant A/C.

C-BUS allocations for the MX809 are shown in Table 5 and Table 6.

Command Assignment	HEX	Address/Command Binary			Command Data
		MSB	LSB		
General Reset	01	00000001			Control Register bits set to logic "0"
Write to Control Register	48	01001000		+	1 byte instruction to Control Register
Read Status Register	49	01001001		+	1 byte reply from Status Register
Read RX Data Buffer	4A	01001010		+	1 byte of data from RX Data Buffer
Write to TX Data Buffer	4B	01001011		+	1 byte of data to TX Data Buffer
Write to SYNC Program	4C	01001100		+	2 bytes of SYNC Word to SYNC Program Register

Table 6: Modem No. 2 C-BUS Address/Commands – (Address Select input at a logic "1")

5.2 Address Select

This input allows 2 MSK Modems on the same BUS, using the correct addressing.

When operating in a system using 2 MSK Modems, one MSK Modem is designated No. 1 and requires its Address Select input to be held at a logic "0". The second Modem (No. 2) requires its Address select input to be held at logic "1".

All C-BUS transactions with Modem 1 will use Address/Command allocations 40_H to 44_H (Table 5) and transactions with Modem 2 will use 48_H to 4C_H (Table 6).

For explanation purposes, further descriptions of MX809 MSK Modem internal register functions will deal primarily with MSK Modem No. 1 (Address Select at logic "0").

5.3 Write to Control Register

This "Write Only" register directs the Modem's operation.

SYNC: When set, this bit enables $\overline{\text{SYNC}}$ Word detection. It is cleared on a successful $\overline{\text{SYNC}}$ Word detection.

SYNC Prime: When set, this bit enables SYNC Word detection. It is cleared on a successful SYNC Word detection.

Interrupt Enable: When set, this bit allows interrupts to be output by the MX809 on the $\overline{\text{IRQ}}$ line.

Powersave: Used in conjunction with the $\overline{\text{Wake}}$ input (see Section 2) to control the Powersave state of the MX809.

Checksum Enable: When set:

In TX: A 2-byte checksum is generated and transmitted after every 6 bytes transmitted.

In RX: After every 8 received bytes (6 information + 2 checksum) the checksum word is checked. If the checksum is correct, the RX Checksum True bit in the Status Register is set to a logic "1". When this bit is a logic "0" no checksum are generated or checked.

Note: Checksum operation is inhibited during the SYNC/ $\overline{\text{SYNC}}$ search period.

Setting	Control bits
MSB	Transmitter first
Bit 7	Not Used
	Set to "0"
6	Not Used
	Set to "0"
5	$\overline{\text{SYNC}}$ Prime
0	
1	Primed
4	SYNC Prime
0	
1	Primed
3	Interrupt Enable
0	Disable
1	Enable
2	Powersave
0	Normal Operation
1	Powersave
1	Checksum Enable
0	Disable
1	Enable
0	RX/TX Mode
0	RX
1	TX

Table 7: Control Register

5.4 RX Data buffer -- "Read RX Data Buffer"

This "Read Only" register contains the last byte of data received from the Data Register. Data is received Bit 7 (MSB) first.

MSB							LSB
7	6	5	4	3	2	1	0
RX Data Buffer							

5.5 TX Data Buffer -- "Write to TX Data Buffer"

This "Write Only" register contains the next byte of data to be transmitted. Bit 7 (MSB) is transmitted first.

MSB							LSB
7	6	5	4	3	2	1	0
TX Data Buffer							

5.6 SYNC Program -- "Write to SYNC Program"

This "Write Only" register is loaded with the required SYNC word. This word (or its opposite logic sense, $\overline{\text{SYNC}}$) is compared with the received synchronization word. If the required SYNC Word is less than 16bits, the remaining bits must be programmed as preamble (10101010...etc). Bit 15 (MSB) is loaded first.

MSB	Byte 1										Byte 2				LSB
15	14	13	12	11	10	9	8	7	6	5	4	3	2	1	0
SYNC High										SYNC Low					

5.7 Read Status Register

This "Read Only" register indicated the source of MX809 interrupts ($\overline{\text{IRQs}}$).

RX $\overline{\text{SYNC}}$ Detect: This is set and an Interrupt is generated when the correct $\overline{\text{SYNC}}$ Word is detected (if $\overline{\text{SYNC}}$ Prime is set).

It is cleared by (1) reading the Status Register, and (2) setting $\overline{\text{RX}}/\text{TX}$ to logic "1".

RX SYNC Detect: This is set and an Interrupt is generated when the correct SYNC Word is detected (if SYNC Prime is set).

It is cleared by (1) reading the Status Register, and (2) setting $\overline{\text{RX}}/\text{TX}$ to logic "1".

TX Idle: This is set and an Interrupt is generated when all loaded TX data and 1 "hang-bit" have been transmitted.

It is cleared by (1) writing to the TX Data Buffer, and (2) setting $\overline{\text{RX}}/\text{TX}$ to logic "0".

TX Data Ready: This is set and an Interrupt generated indicating that a byte of data should be written to the TX Data Buffer.

It is cleared by (1) reading the Status Register and writing a byte of data to the TX Data Buffer, and (2) setting $\overline{\text{RX}}/\text{TX}$ to logic "0".

RX Data Ready: When this is set and an Interrupt generated, it indicates that the RX Data Buffer is full, and that a byte of data is to be read from the RX Data buffer. This must be read within 8 bit periods.

It is cleared by (1) reading the Status Register and the RX Data buffer, and (2) setting the $\overline{\text{RX}}/\text{TX}$ to logic "1".

RX Checksum True: This is set and an Interrupt is generated by a successful comparison of the received and self-generated checksums.

It is cleared by (1) reading the Status Register and the RX Data Buffer, and (2) $\overline{\text{RX}}/\text{TX}$ being taken to logic "1".

Reading	Status Bits
MSB	Received First
Bit 7	Undefined
0 1	"0" or "1"
6	Undefined
0 1	"0" or "1"
5	RX SYNC Detect
0 1	$\overline{\text{SYNC}}$
4	RX SYNC Detect
0 1	SYNC
3	TX Idle
0 1	Idle
2	TX Data Ready
0 1	TX Date Ready
1	RX Checksum True
0 1	True
0	RX Data Ready
0 1	RX Data Ready

Table 8: Status Register

5.8 Interrupt Request

The conditions that cause interrupts to be output (if enabled by the Control Register) from the MX809 are:

TX Idle
 TX Data Ready
 RX $\overline{\text{SYNC}}$ Detect
 RX Data Ready
 RX SYNC Detect

The Status Register should be read to find the cause of the interrupt. Interrupts are cleared by (1) reading the Status Register, or (2) changing the state of the $\overline{\text{RX}}$ / TX bit.

5.9 General Reset

Upon power-up, the bits in the MX809 Mode register and buffer will be random (either "0" or "1"). The General Reset command (01 μ) will "reset" all microcircuits in the C-BUS and had the following effect on the MX809.

All bits in the Control Register will be set to logic "0". The Tx Out output will be set to V_{BIAS} .

Note: The Status register, RX Data Buffer, TX Data Buffer, and SYNC Program register are not affected by the General Reset Command.

6 Application

6.1 Checksum Generation and Checking

6.1.1 Generation

The checksum generator takes the 48 bits from the 6 bytes loaded into the TX Data Buffer and divides them into modulo-2 by the generating polynomial:

$$x^{15} + x^{14} + x^{13} + x^{11} + x^4 + x^2 + x^1$$

It then takes the 15-bit remainder from the polynomial divider, inverts the last bit and appends an EVEN parity bit generated from the initial 48 bits and the 15 bit remainder (with the last bit inverted). This 16 bit word is used as the "Checksum".

6.1.2 Checking

The checksum checker does two things:

1. It takes the first 63 bits of a received message, inverts bit 63, and divides them modulo-2 by the generating polynomial:

$$x^{15} + x^{14} + x^{13} + x^{11} + x^4 + x^2 + x^1$$

2. The 15 bits remaining in the polynomial divider are checked to make sure that they are all zero.
3. It generates an even parity bit from the first 63 bits of a received message and compares this bit with the received parity (bit 64).

If the 15 bits in the polynomial divider are all zero and the two parity bits are equal, then the RX Checksum True (Status Register bit 1) is set.

6.2 Modem Performance

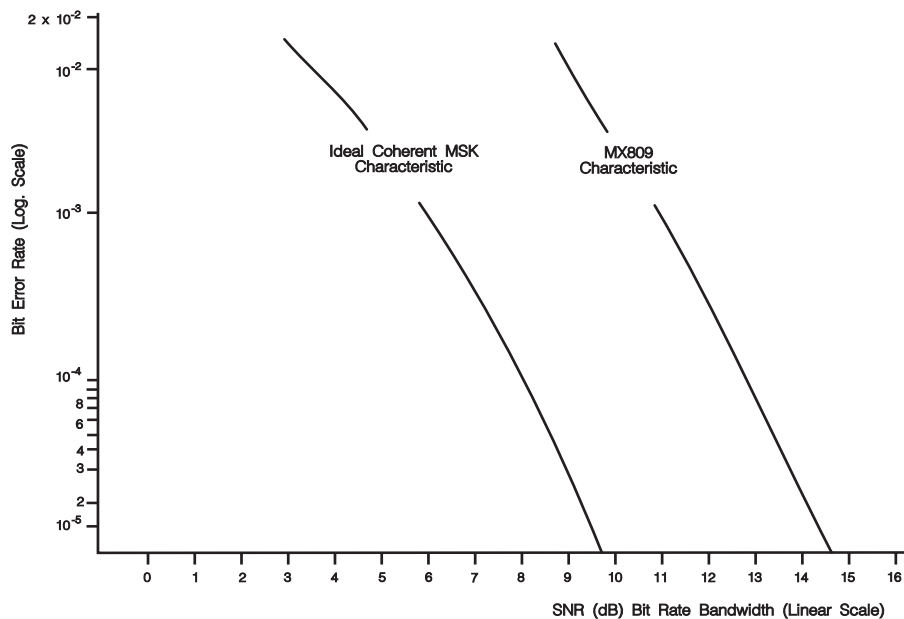

Figure 3: Bit Error Rate vs. Signal-to-Noise Ratio

6.3 Modem Timing Information

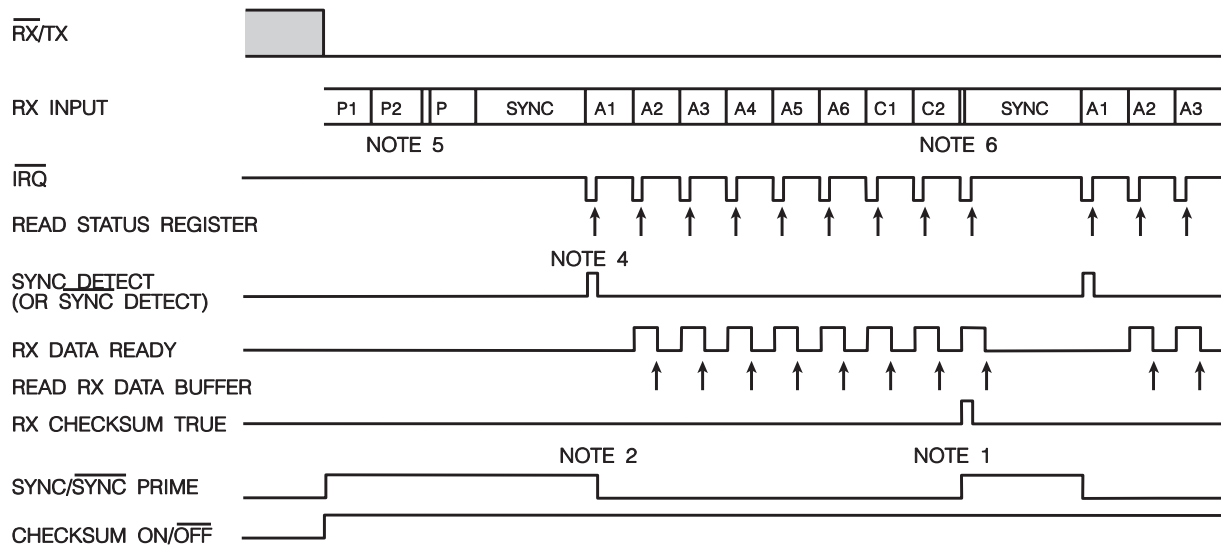

Figure 4: Modem Timing

Notes:

1. The SYNC and $\overline{\text{SYNC}}$ detector searches the incoming bit stream starting at the end of the byte in which SYNC/ $\overline{\text{SYNC}}$ Prime was set.
2. After detection of a SYNC/ $\overline{\text{SYNC}}$ word, the SYNC/ $\overline{\text{SYNC}}$ Prime bits automatically go low (control bits 5 and 6: detector off).
3. The checksum checker is inhibited during the time SYNC/ $\overline{\text{SYNC}}$ search is operating.
4. The Status Register will indicate whether SYNC or $\overline{\text{SYNC}}$ was detected here.
5. Any number of preamble bits can occur here.
6. Any number of bits can occur here.
7. $\overline{\text{RX}}$ Freeformat set high.

6.4 TX Timing

A – Address bytes C – Checksum bytes D – Data bytes H – Hang bit P – Preamble bytes	■ - Don't care state TX only – In TX, Preamble, and SYNC are loaded as data from the microcontroller.
---	--

6.4.1 TX More Than One Message, SYNC Before Every Message, TX Checksum Enabled

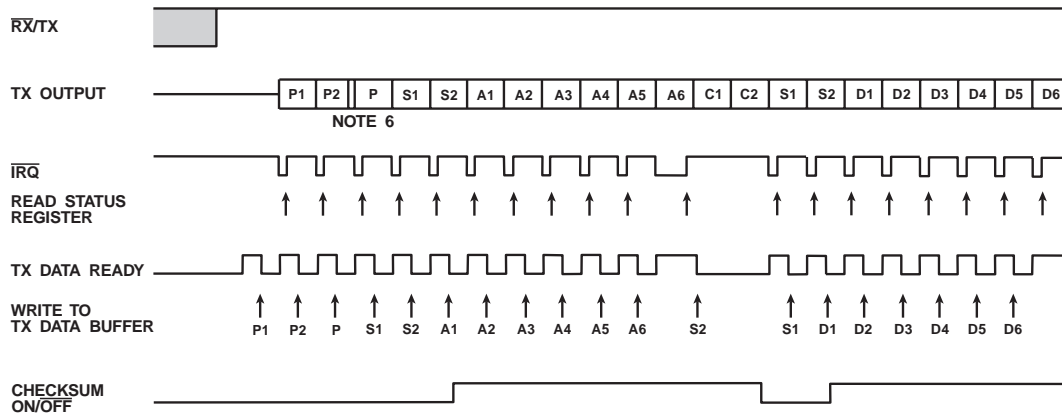

Figure 5: TX More Than One Message, SYNC Before Every Message, TX Checksum Enabled

Notes:

1. Preamble and SYNC bytes are loaded as data from the microcontroller.
2. The TX output will be held at bias level when no data is being transmitted.
3. TX byte synchronization is established by loading of the first preamble byte from the microcontroller.
4. Checksum must be turned off during preamble and SYNC words.
5. When \overline{RX}/TX is low, TX output is at bias.
6. Any number of preamble bytes can occur here.

6.4.2 TX More Than One Message, TX Checksum Not Enabled.

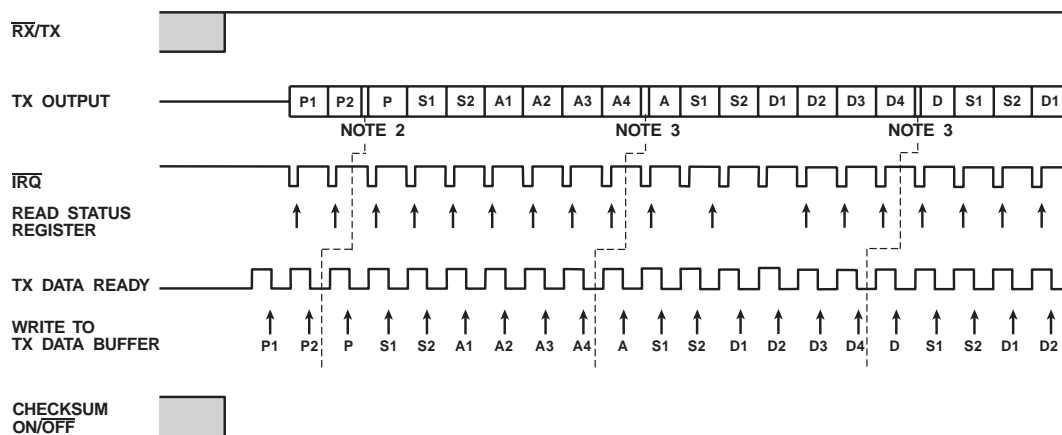

Figure 6: TX More Than One Message, TX Checksum Not Enabled.

Notes:

1. Preamble, SYNC words and checksums are supplied by the microcontroller in this format as data bytes.
2. Any number of preamble bytes can occur here.
3. Any number of address/data bytes can occur here.

6.4.3 TX One Message, TX Checksum Enabled

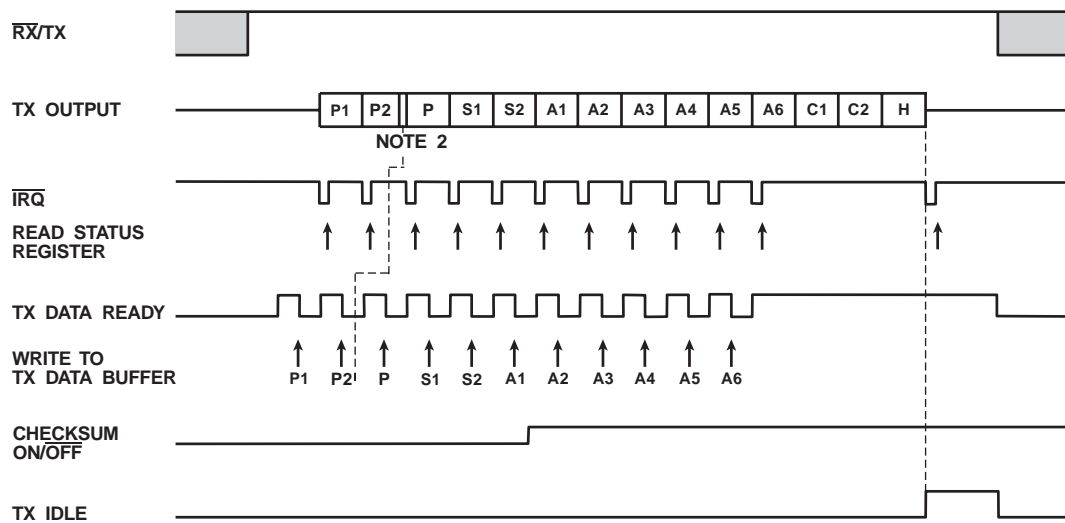

Figure 7: TX One Message, TX Checksum Enabled

Notes:

1. H is the "Hangover bit" (Logic1) appended to the transmitted message before transmission is terminated.
2. Any number of preamble bytes can occur here.
3. Transmission terminates after C1, C2, and H. Termination occurs when no further data bytes are written to the TX Data Buffer.

6.4.4 TX One Message, TX Checksum Not Enabled.

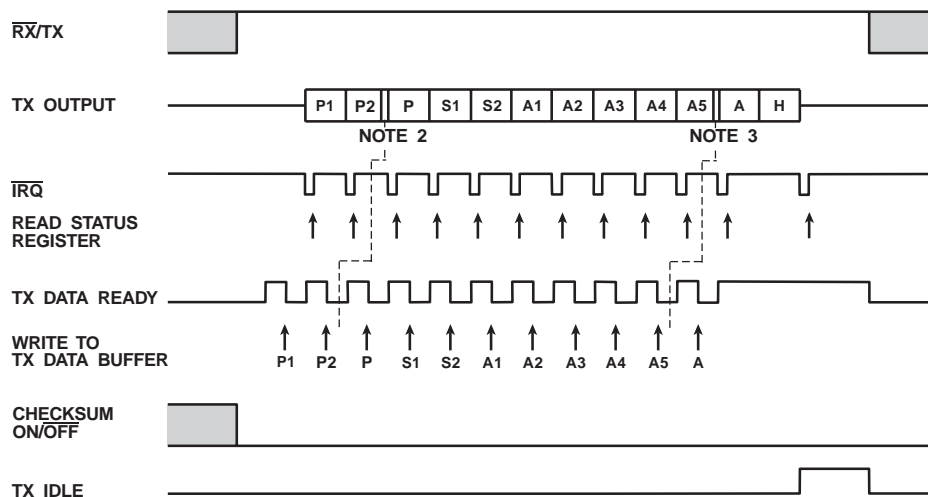

Figure 8: TX One Message, TX Checksum Not Enabled

Notes:

1. H is the "Hangover bit" (Logic1) appended to the transmitted message before transmission is terminated.
2. Any number of preamble bytes can occur here.
3. Any number of address/data bytes can occur here.
4. Transmission terminates when no further data bytes are loaded into the TX Data Buffer.

6.5 RX Timing

<p>A – Address bytes C – Checksum bytes D – Data bytes H – Hang bit P – Preamble bytes</p>	<p>■ - Don't care state</p> <p>TX only – In TX, Preamble, and SYNC are loaded as data from the microcontroller.</p>
--	---

6.5.1 RX SYNC / $\overline{\text{SYNC}}$ Required Before Every Message, Rx Checksum Not Enabled

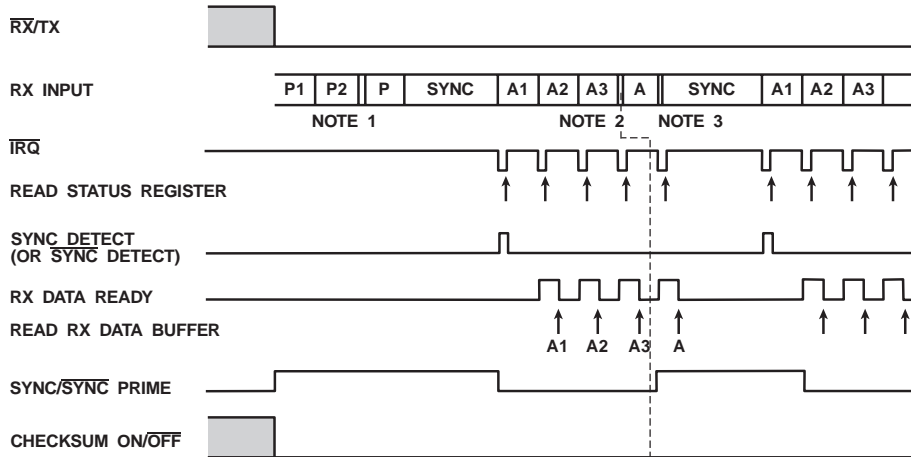

Figure 9: RX SYNC / $\overline{\text{SYNC}}$ Required Before Every Message, RX Checksum not Enabled

Notes:

1. Any number of preamble bits can occur here.
2. Any number of address/data bytes can occur here.
3. Any number of bits can occur here
4. $\overline{\text{RX}}$ Freeformat set high.

6.5.2 RX Additional Data Follows Initial Address (6 Data & 2 Checksum Bytes) Data, RX checksum Enabled

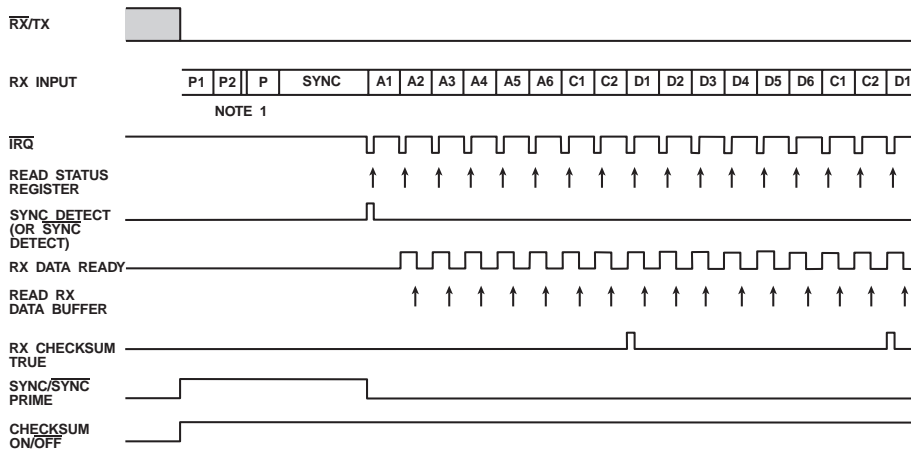

Figure 10: RX Additional Data Follows Initial Address (6 Data & 2 Checksum Bytes) Data , RX Checksum Enabled

Notes:

1. Any number of preamble bits can occur here.
2. $\overline{\text{RX}}$ Freeformat set high.

7 Performance Specifications

7.1 Electrical Specifications

7.1.1 Absolute Maximum Limits

Exceeding these maximum ratings can result in damage to the device.

General	Notes	Min.	Typ.	Max.	Units
Supply ($V_{DD}-V_{SS}$)		-0.3		7.0	V
Voltage on any pin to V_{SS}		-0.3		$V_{DD} + 0.3$	V
Current					
V_{DD}		-30		30	mA
V_{SS}		-30		30	mA
Any other pin		-20		20	mA
J / LH Packages					
Total allowable Power dissipation at $T_{AMB} = 25^{\circ}\text{C}$				800	mW
Derating above 25°C			10		mW/ $^{\circ}\text{C}$ above 25°C
Operating Temperature		-40		85	$^{\circ}\text{C}$
Storage Temperature		-55		125	$^{\circ}\text{C}$

Table 9: Absolute Maximum Ratings

7.1.2 Operating Limits

Correct Operation of the device outside these limits is not implied.

	Notes	Min.	Typ.	Max.	Units
Supply ($V_{DD}-V_{SS}$)		4.5	5.0	5.5	V
Operating Temperature		-40		85	$^{\circ}\text{C}$
Xtal Frequency			4.032		MHz

Table 10: Operating Limits

7.1.3 Operating Characteristics

For the following conditions unless otherwise specified.

$V_{DD} = 5.0V$ @ $T_{AMB} = 25^{\circ}C$

Xtal/Clock Frequency = 4.032MHz, Audio Level 0dB ref. = 308mV_{RMS} @ 1kHz

Bit Rate = 1200bps

	Notes	Min.	Typ.	Max.	Units
Static Values					
Supply Current					
Enabled			5.0		mA
Powersave			2.0		mA
Dynamic Values					
Digital Interface					
Input Logic "1"	1	3.5			V
Input Logic "0"	1			1.5	V
Output Logic "1" ($I_{OH} = -120\mu A$)	2	4.6			V
Output Logic "0" ($I_{OH} = 360\mu A$)	2, 3			0.4	V
Digital Input Current					
$V_{IN} =$ Logic "1" or "0"	1			1.0	μA
Digital Input Capacitance	1			7.5	pF
Tri-State "OFF" Leakage Current	8	-4.0		4.0	μA
Analog Impedance					
Input Impedance		100			k Ω
Output Impedance					
Transmitting Data			6.0	10.0	k Ω
Not Transmitting Data			1.0		k Ω
On-Chip Xtal Oscillator					
R_{IN}		10.0			M Ω
R_{OUT}		5.0			k Ω
Gain			15.0		dB
Frequency	4		4.032		MHz
Receiver					
Signal Input Levels	5	-9.0	-2.0	10.5	dB
Bit Error Rate					
At 12dB SNR			7.0		10^{-4}
At 20dB SNR			1.0		10^{-8}
Synchronization at 12dB SNR	6				
Probability of Bit 8 being correct			99.0		%
Probability of Bit 16 being correct			99.5		%

	Notes	Min.	Typ.	Max.	Units
Transmitter					
Output Level			0		dB
Output Level Variation		-1.0		1.0	dB
Output Distortion			3.0	5.0	%
Third Harmonic Distortion			2.0	3.0	%
Logic "1" Frequency	7		1200		Hz
Logic "0" Frequency	7		1800		Hz
Isochronous Distortion					
1200Hz – 1800Hz			25.0	40.0	μs
1800Hz – 1200Hz			20.0	40.0	μs
Uncommitted Amplifier					
Bandwidth			200		kHz
Gain			50.0		dB
Input Impedance		1.0			
Output Impedance				10.0	kΩ

Table 11: Operating Characteristics

Operating Characteristics Notes:

1. Device control pins: Serial Clock, Command Data, $\overline{\text{Wake}}$, and $\overline{\text{CS}}$.
2. Reply Data output.
3. $\overline{\text{IRQ}}$ output
4. For baud rate specified (1200 baud)
5. Signal-to-Noise Ratio = 50dB
6. The response time is measured using 10101010...101 signal input pattern at 230mV_{RMS} (-2.5dB) with noise.
7. Dependant upon Xtal tolerance.
8. $\overline{\text{IRQ}}$ and Reply Data outputs for $V_{SS} < V_{OUT} < V_{DD}$.

7.1.4 Timing

C-BUS Timing		Min.	Typ.	Max.	Units
t_{CSE}	Chip Select Low to First Serial Clock Rising Edge	2.0			μ S
t_{CHS}	Last Serial Clock Rising Edge to Chip Select High	4.0			μ S
t_{HIZ}	Chip Select High to Reply Data High -Z			2.0	
t_{CSOFF}	Chip Select High time between transactions	2.0			μ S
t_{NXT}	Inter-Byte Time	4.0			μ S
t_{CK}	Serial Clock Period	2.0			μ S

Table 12: Timing Information

Notes:

1. Depending on the command, 1 or 2 bytes of Command Data is transmitted to the peripheral MSB (bit 7) first, LSB (bit 0) last. Reply Data is read from the peripheral MXB (bit 7) first, LSB (bit 0) last.
2. Data is clocked into and out of the peripheral on the rising Serial Clock edge.
3. Loaded commands are acted upon at the end of each command.
4. To allow for differing microcontroller serial interface formats, C-BUS compatible ICs are able to work with either polarity Serial Clock pulses.

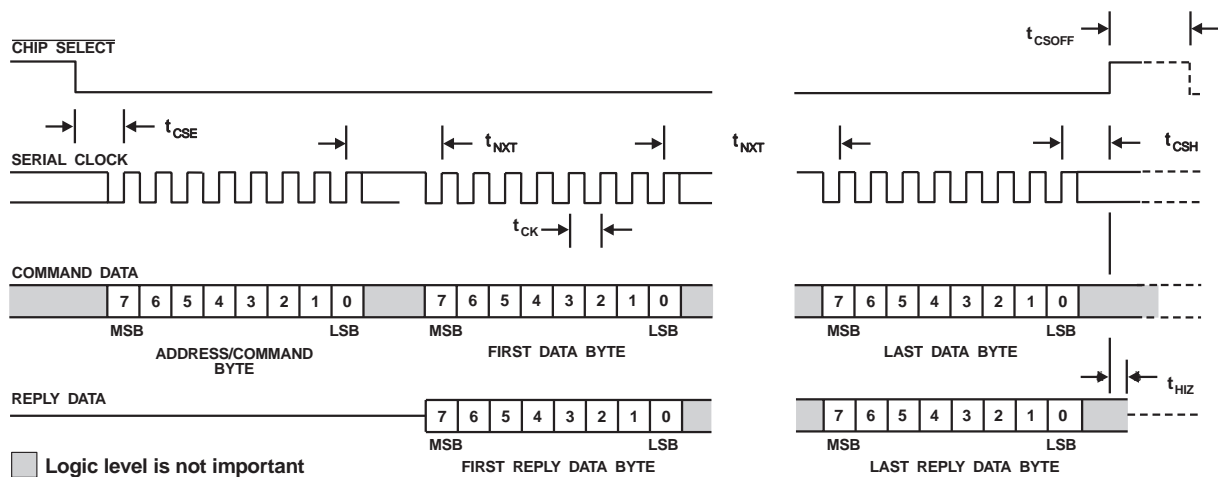

Figure 11: C-BUS Timing Information

7.2 Packages

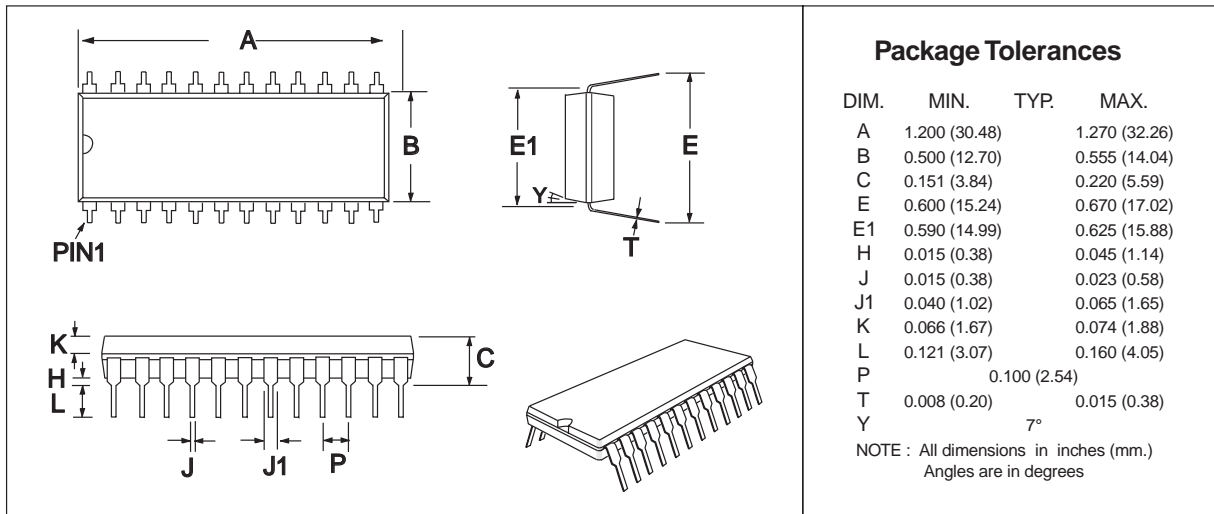

Figure 12: 24-pin CERDIP Mechanical Outline: Order as part no. MX809J

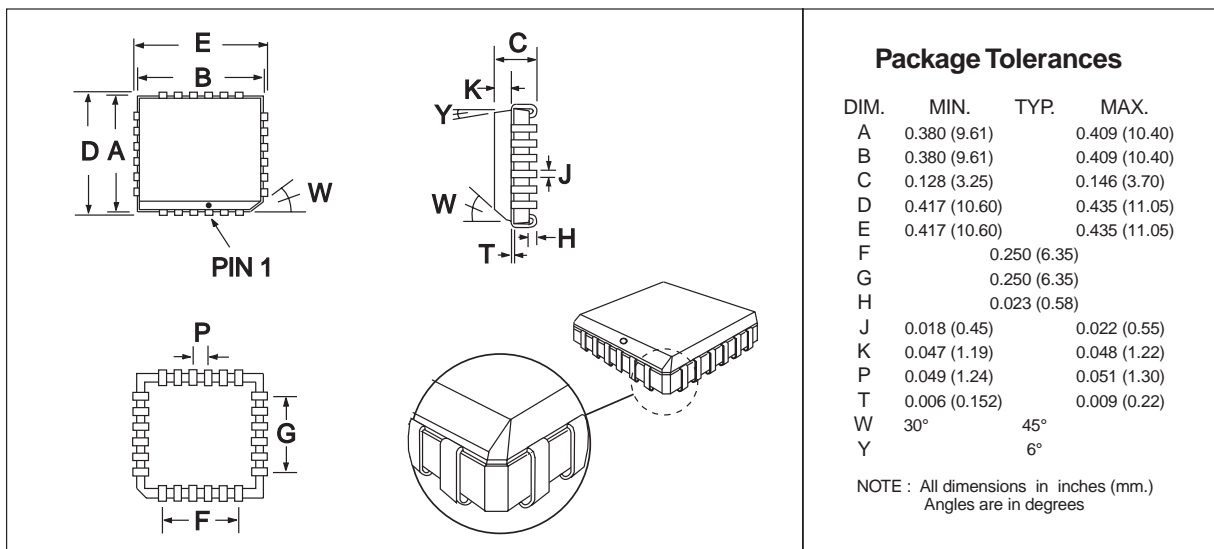

Figure 13: 24-pin PLCC Mechanical Outline: Order as part no. MX809LH