

8051 Embedded USB/PS2 Keyboard/Mouse Controller

FEATURES

- 8051 core, 6MHz operating frequency.
- 256-byte RAM, 8K-byte program Flash-ROM.
- Compliant with Low Speed USB Spec. 1.1 including 3 Endpoints: one is Control endpoint (8-byte IN & 8-byte OUT FIFOs), the other two are Interrupt endpoints (8-byte IN FIFOs).
- Built-in 3.3V regulator for USB Interface.
- Suspend / Resume operation.
- Idle and Power down mode wake-up by interrupt.
- 8 dedicated Key scan input pins and 18/19 Key scan output pins.
- Built-in low power reset circuit and Watchdog timer.
- PS2 compatible mouse interface.
- PS2 compatible keyboard interface share with USB interface.
- CPU clock can be double by S/W setting.
- 40-pin DIP, 42-pin SDIP or 44-pin PLCC package.

GENERAL DESCRIPTIONS

The MTP805 micro-controller is an 8051 CPU core embedded device specially tailored to USB/PS2 Keyboard/Mouse applications. It includes an 8051 CPU core, 256-byte SRAM, Low Speed USB Interface and an 8K-byte internal program Flash-ROM.

BLOCK DIAGRAM

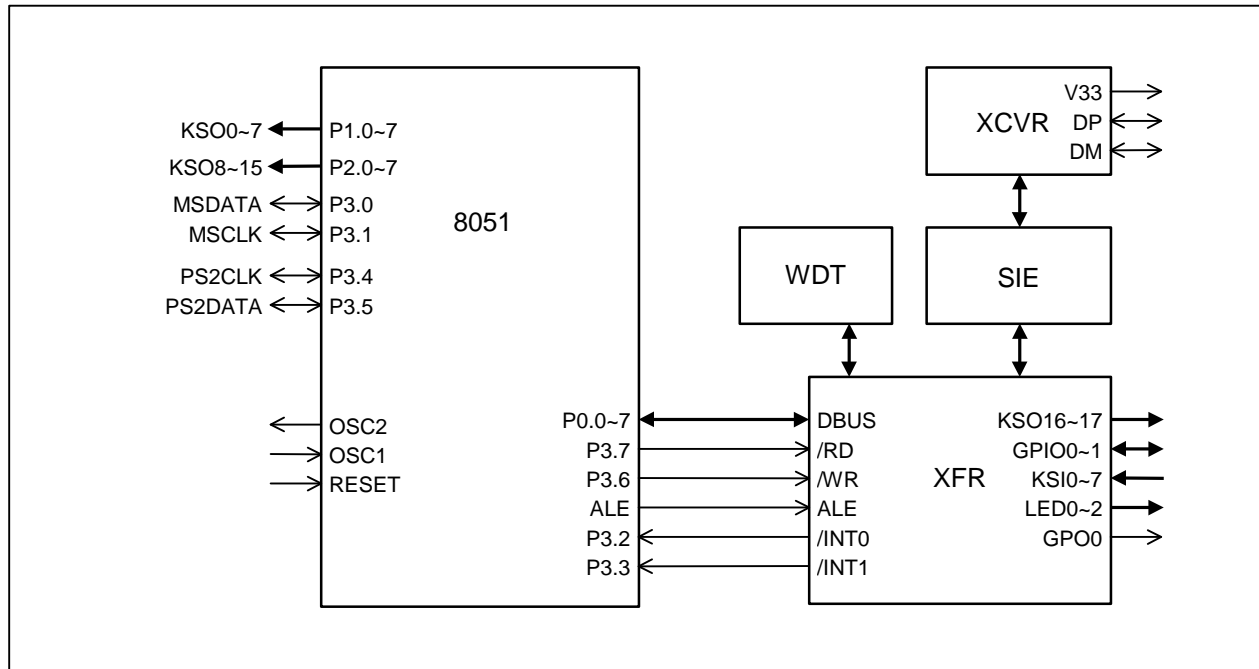

This datasheet contains new product information. Myson Technology reserves the rights to modify the product specification without notice. No liability is assumed as a result of the use of this product. No rights under any patent accompany the sale of the product.

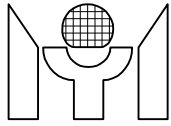

PIN CONNECTION

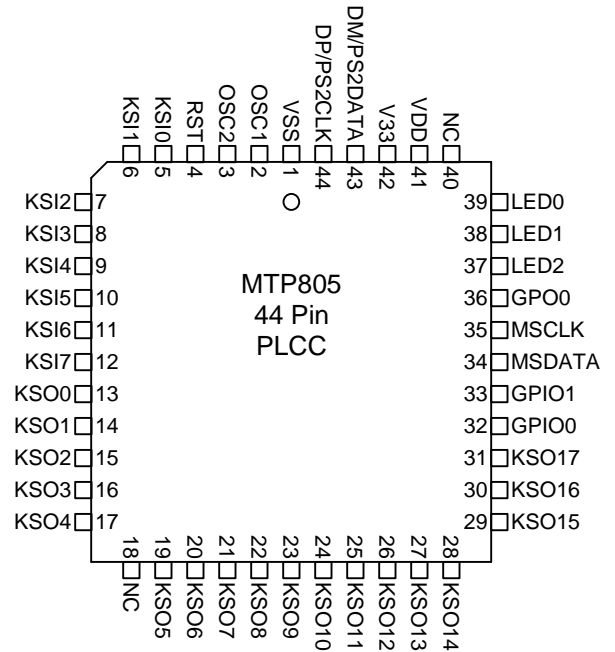
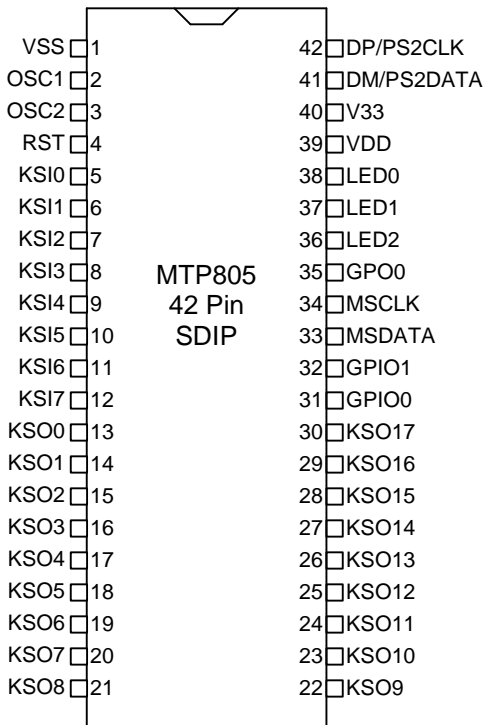
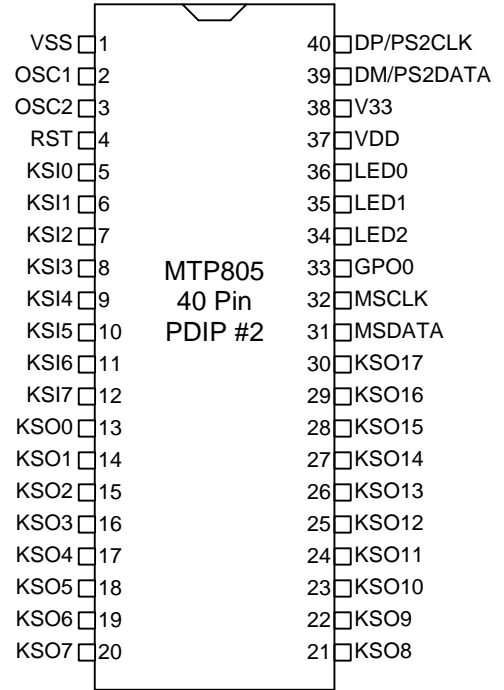
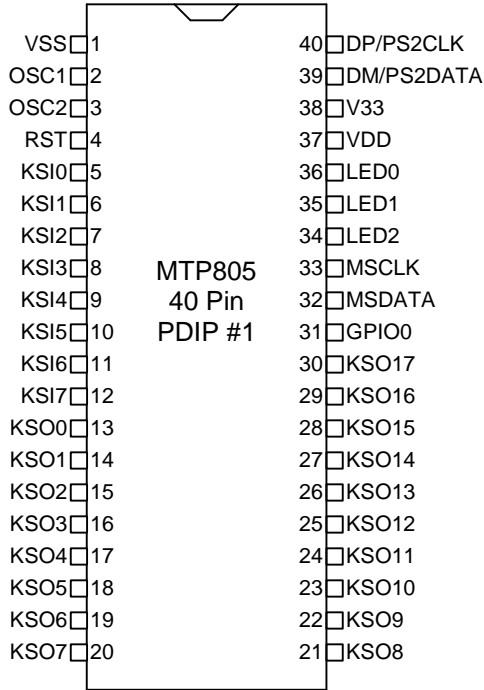

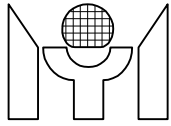

PIN DESCRIPTION

Name	Type	Description
VSS	-	Ground.
OSC1	I	Oscillator input.
OSC2	O	Oscillator output.
RST	I	Active high reset. (with internal pull-down resistor)
KSI0	I	Key scan input 0. (Schmitt-trigger with 10K/33K/50K pull-up resistor)
KSI1	I	Key scan input 1. (Schmitt-trigger with 10K/33K/50K pull-up resistor)
KSI2	I	Key scan input 2. (Schmitt-trigger with 10K/33K/50K pull-up resistor)
KSI3	I	Key scan input 3. (Schmitt-trigger with 10K/33K/50K pull-up resistor)
KSI4	I	Key scan input 4. (Schmitt-trigger with 10K/33K/50K pull-up resistor)
KSI5	I	Key scan input 5. (Schmitt-trigger with 10K/33K/50K pull-up resistor)
KSI6	I	Key scan input 6. (Schmitt-trigger with 10K/33K/50K pull-up resistor)
KSI7	I	Key scan input 7. (Schmitt-trigger with 10K/33K/50K pull-up resistor)
KSO0	O	Key scan output 0 (8051's P1.0). (Pseudo open-drain)
KSO1	O	Key scan output 1 (8051's P1.1). (Pseudo open-drain)
KSO2	O	Key scan output 2 (8051's P1.2). (Pseudo open-drain)
KSO3	O	Key scan output 3 (8051's P1.3). (Pseudo open-drain)
KSO4	O	Key scan output 4 (8051's P1.4). (Pseudo open-drain)
KSO5	O	Key scan output 5 (8051's P1.5). (Pseudo open-drain)
KSO6	O	Key scan output 6 (8051's P1.6). (Pseudo open-drain)
KSO7	O	Key scan output 7 (8051's P1.7). (Pseudo open-drain)
KSO8	O	Key scan output 8 (8051's P2.0). (Pseudo open-drain)
KSO9	O	Key scan output 9 (8051's P2.1). (Pseudo open-drain)
KSO10	O	Key scan output 10 (8051's P2.2). (Pseudo open-drain)
KSO11	O	Key scan output 11 (8051's P2.3). (Pseudo open-drain)
KSO12	O	Key scan output 12 (8051's P2.4). (Pseudo open-drain)
KSO13	O	Key scan output 13 (8051's P2.5). (Pseudo open-drain)
KSO14	O	Key scan output 14 (8051's P2.6). (Pseudo open-drain)
KSO15	O	Key scan output 15 (8051's P2.7). (Pseudo open-drain)
KSO16	I/O	Key scan output 16. (Pseudo open-drain)
KSO17	I/O	Key scan output 17. (Pseudo open-drain)
GPIO0	I/O	General purpose I/O 0. (Pseudo open-drain)
GPIO1	I/O	General purpose I/O 1. (Pseudo open-drain)
MSDATA	I/O	Mouse data (8051's P3.0). (Pseudo open-drain)
MSCLK	I/O	Mouse clock (8051's P3.1). (Pseudo open-drain)
GPO0	O	General purpose output 0. (Open-drain with 420 ohm serial resistor)
LED2	O	Output pin to drive LED 2. (Open-drain with 420 ohm serial resistor)
LED1	O	Output pin to drive LED 1. (Open-drain with 420 ohm serial resistor)
LED0	O	Output pin to drive LED 0. (Open-drain with 420 ohm serial resistor)
VDD	-	Positive Power Supply.
V33	O	3.3 Volt USB regulator output. (Must connect to 1uF or larger capacitor)
DM/PS2DATA	I/O	USB DM / PS2 keyboard data (8051's P3.5).
DP/PS2CLK	I/O	USB DP / PS2 keyboard clock (8051's P3.4).

“Pseudo open-drain” pin is 8051 Port1’s standard. It can sink at least 4mA current when output low level, and drive at least 4mA current for 2 X’tal cycle when output transit from low to high, then keep drive 100uA to maintain the pin at high level.

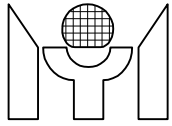

FUNCTIONAL DESCRIPTIONS

1. 8051 CPU Core

MTP805 includes all 8051 functions with the following exceptions:

- 1.1 PSEN, ALE, #RD and #WR pins are disabled. The external RAM access is restricted to XFRs within the MTP805.
- 1.2 Port0, port3.2, port3.3, port3.6 and port3.7 are not general-purpose I/O ports. They are dedicated to special application.
- 1.3 #INT0 and #INT1 input pin is not provided, it is connected to special interrupt sources.
- 1.4 UART and Timer1 are not supported.

Note: All registers listed in this document reside in external RAM area (XFR). For internal RAM memory map please refer to 8051 spec.

2. Memory Allocation

2.1 Internal Special Function Registers (SFR)

The SFR is a group of registers that are the same as standard 8051.

2.2 Internal RAM

There are total 256 bytes internal RAM in MTP805, same as standard 8052.

2.3 External Special Function Registers (XFR)

The XFR is a group of registers allocated in the 8051 external RAM area 00h - 2Fh. Most of the registers are used for USB function. Program can initialize Ri value and use "MOVX" instruction to access these registers.

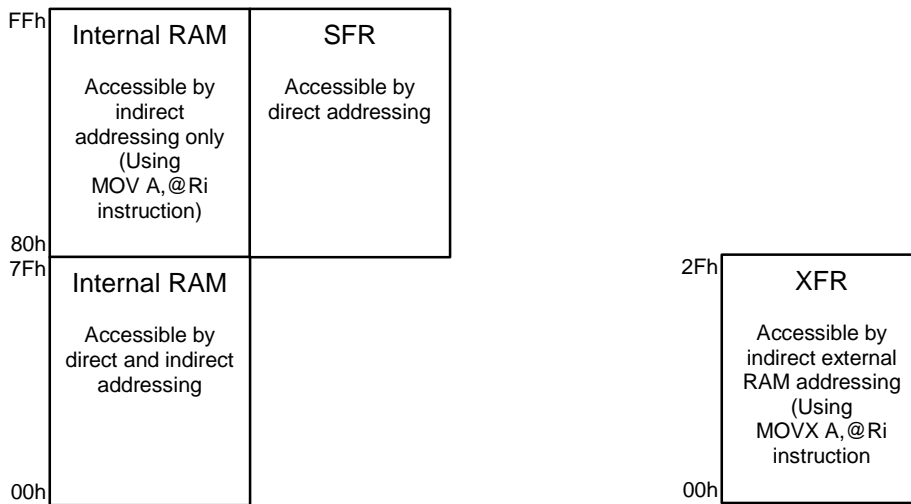

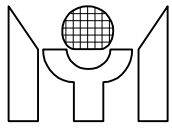

3. I/O Pin Usage

3.1 KSO0~7

These pins are direct output from the 8051's Port1 and dedicated for key scan output. The pin's input function is removed. Read 8051's Port1 is only read the data in the Port1's output register. These pins are "Pseudo open-drain" structure.

3.2 KSO8~15

These pins are direct output from the 8051's Port2 and dedicated for key scan output. The pin's input function is removed. Read 8051's Port2 is only read the data in the Port2's output register. These pins are "Pseudo open-drain" structure.

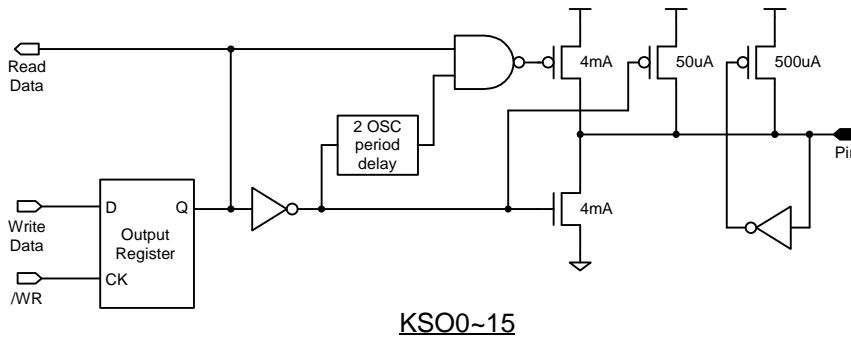

3.3 KSO16~17, GPIO0~1

These pins are output from MTP805's XFR. They can be used as key scan output or general purpose I/O. Read these pins will read the data on pin. These pins are also "Pseudo open-drain" structure.

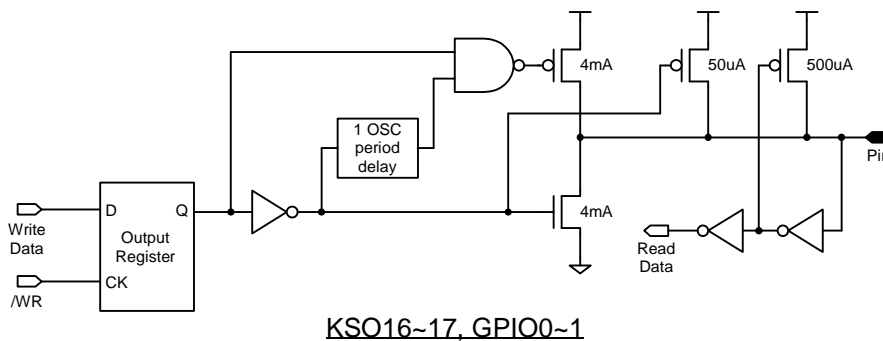

3.4 MSCLK, MSDATA

These pins are connected to 8051's P3.1 and P3.0. The usage of these pins are the same as standard 8051 except the UART's function being not provided. These pins are also "Pseudo open-drain" structure.

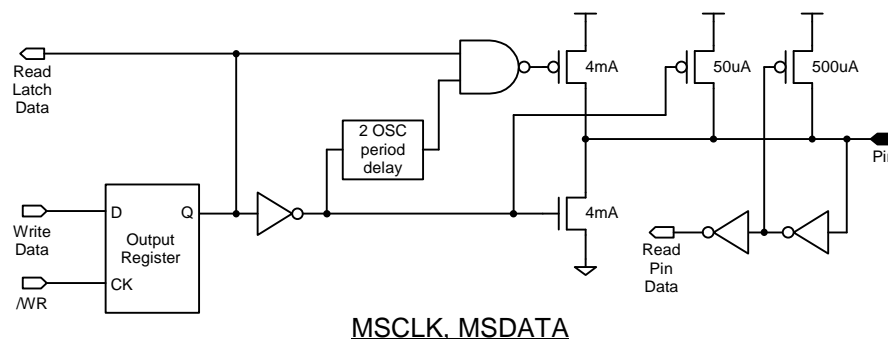

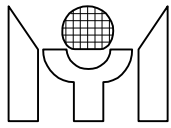

3.5 PS2CLK, PS2DATA

These pins are shared with USB's DP/DM pins. They are connected to 8051's P3.4 and P3.5. In PS2 mode, S/W should keep "ENUSB"=0 and "PS2KB"=1. In USB mode, S/W should keep "ENUSB"=1, "PS2KB"=0 and P3.4/P3.5 output high. These pins are also "Pseudo open-drain" structure in PS2 mode.

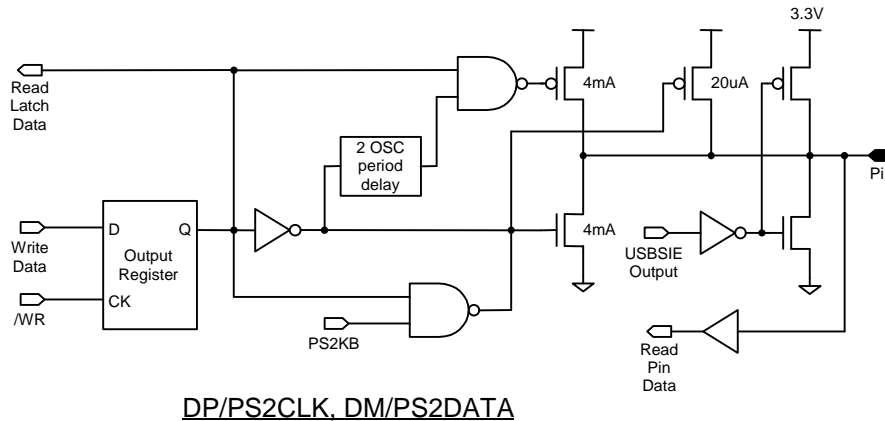

3.6 LED0~2, GPO0

These pins are used to drive LED. Basically, they are open-drain structure. Each one has a 420 ohm serial resistor when sink pin to low, and has a 100K resistor when drive high. S/W may write data to "LED" register to control these pins' status. Read "LED" only read the data in the "LED" register, instead of data on the pins.

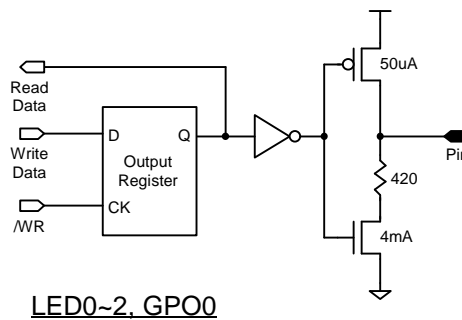

3.7 KSI0~7

These pins are used as key scan input. Reading "KSI" register of XFR reflect the data on the pin. These pins are input only with pull-up resistor on each pin.

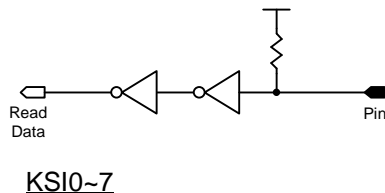

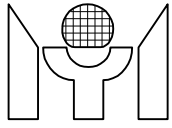

4. USB and PS2 Mode Detection

After reset, the USB transceiver is disabled, and the V33 pin is in high impedance state (no 3.3 volt output). S/W can detect the application is USB mode or PS2 mode by reading P3.4/P3.5. At first, S/W can set "PS2KB"=1. This control bit is used to enable the internal 250K pull-up resistor on DP/DM pin. If the chip is connected to USB Hub, the P3.4/P3.5 is 0 because of the 15K pull-down resistor on Hub. Otherwise, P3.4/P3.5 is 1.

5. Power-down and Idle Mode

The Power-down/Idle mode is activated by S/W setting the PD/IDL bit in 8051's PCON register. In Power-down mode, the MTP805's X'tal stop oscillating. In Idle mode, the 8051's instruction clock is stop. The Power-down/Idle mode is released by any enable interrupt. For standard 8051, Power-down mode is released only by chip reset.

6. Watch-Dog-Timer(WDT) and Low-Voltage-Reset(LVR)

The WDT is enable by setting the "WDTen" bit in XFR. The time out period is 0.64 second. S/W can clear WDT by writing the WDT register.

The LVR can generate chip reset when VDD is below 3.0 volt, including both power-on and power-off process.

7. Fast Clock Option

The CPU can run at double clock rate when S/W setting the "FCLKen" bit in XFR. Once setting, the 8051 is running at the rate as if a 12MHz X'tal is on OSC pins. However, S/W must clear the FCLKen bit before entering Power-down mode.

8. USB Engine

The USB engine includes the Serial Interface Engine (SIE), the low-speed USB I/O transceiver and the 3.3 Volt Regulator. The SIE block performs most of the USB interface function with only minimum support from S/W. Three endpoints are supported. Endpoint 0 is used to receive and transmit control (including SETUP) packets while Endpoint 1 and endpoint 2 are only used to transmit data packets.

The USB SIE handles the following USB bus activity independently:

1. Bitstuffing/unstuffing
2. CRC generation/checking
3. ACK/NAK
4. TOKEN type identification
5. Address checking

S/W handles the following tasks:

1. Coordinate enumeration by responding to SETUP packets
2. Fill and empty the FIFOs
3. Suspend/Resume coordination
4. Verify and select DATA toggle values

8.1 USB Device Address

The USBADR register stores the device address. This register is reset to all 0 after chip reset or USB bus reset. S/W must write this register a valid value after the USB enumeration process.

8.2 Endpoint 0 receive

After receiving a packet and placing the data into the Endpoint 0 receive FIFO (RC0FIFO), MTP805 updates the Endpoint 0 status register (EP0STUS) to record the receive status and then generates an Endpoint 0

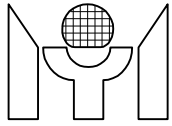

receive interrupt (RC0I). S/W can read the EP0STUS register for the recent transfer information, which includes the data byte count (RC0cnt), data direction (EP0dir), SETUP token flag (EP0set) and data valid flag (RC0err). The received data is always stored into RC0FIFO and the RC0cnt is always updated for DATA packets following SETUP tokens. The data following an OUT token is written into the RC0FIFO, and the RC0cnt is updated unless Endpoint 0 STALL (EP0stall) is set or Endpoint 0 receive ready (RC0rdy) is cleared. The SIE clears the RC0rdy automatically and generates RC0I interrupt when the RC0cnt/RC0FIFO is updated. As long as the RC0rdy is cleared, SIE keep responding NAK to Host's Endpoint 0 OUT packet request. S/W should set the RC0rdy flag after the RC0I interrupt is asserted and RC0FIFO is read out.

8.3 Endpoint 0 transmit

After detecting a valid Endpoint 0 IN token, MTP805 automatically transmit the data pre-stored in the Endpoint 0 transmit FIFO (TX0FIFO) to the USB bus if the Endpoint 0 transmit ready flag (TX0rdy) is set and the EP0stall is cleared. The number of byte to be transmitted is base on the Endpoint 0 transmit byte count register (TX0cnt). The DATA0/1 token to be transmitted is base on the Endpoint 0 transmit toggle control bit (TX0tgl). After the TX0FIFO is updated, TX0rdy should be set to 1. This enables the MTP805 to respond to an Endpoint 0 IN packet. TX0rdy is cleared and an Endpoint 0 transmit interrupt (TX0I) is generated once the USB host acknowledges the data transmission. The interrupt service routine can check TX0rdy to confirm that the data transfer was successful.

8.4 Endpoint 1/2 transmit

Endpoint1 and Endpoint2 are capable of transmit only. These endpoints are enable when the Endpoint1/Endpoint2 configured control bit (EP1cfgd/EP2cfgd) is set. After detecting a valid Endpoint 1/2 IN token, MTP805 automatically transmit the data pre-stored in the Endpoint 1/2 transmit FIFO (TX1FIFO/TX2FIFO) to the USB bus if the Endpoint 1/2 transmit ready flag (TX1rdy/TX2rdy) is set and the EP1stall/EP2stall is cleared. The number of byte to be transmitted is base on the Endpoint 1/2 transmit byte count register (TX1cnt/TX2cnt). The DATA0/1 token to be transmitted is base on the Endpoint 1/2 transmit toggle control bit (TX1tgl/TX2tgl). After the TX1FIFO/TX2FIFO is updated, TX1rdy/TX2rdy should be set to 1. This enables the MTP805 to respond to an Endpoint 1/2 IN packet. TX1rdy/TX2rdy is cleared and an Endpoint 1/2 transmit interrupt (TX1I/TX12) is generated once the USB host acknowledges the data transmission. The interrupt service routine can check TX1rdy/TX2rdy to confirm that the data transfer was successful.

8.5 USB Control and Status

Other USB control bits include the USB enable (ENUSB), SUSPEND (Susp), RESUME (RsmO), Control Read (CtrRD), and corresponding interrupt enable bits. The CtrRD should be set when program detects the current transfer is an Endpoint0 Control Read Transfer. Once this bit is set, the MTP805 will stall an Endpoint0 OUT packet with DATA toggle 0 or byte count other than 0. Other USB status flag includes the USB reset interrupt (RstI), RESUME interrupt (RsmI), and USB Suspend interrupt (SusI).

8.6 Suspend and Resume

Once the Suspend condition is asserted, S/W can set the Susp bit to stop the USBSIE's clock. In the mean time, the 3.3V Regulator is operating in low power mode. S/W can further save the device power by force the 8051 CPU core into the Power Down or Idle mode by setting the PCON register in SFR area. In the Idle mode, the X'tal keeps oscillating and CPU can be waken-up by the trigger of any enabled interrupt. In the Power Down mode, the X'tal is stop, but CPU can be waken-up by the trigger of enabled interrupt's source. In short, S/W can keep the RsmI/KbdI/MsI alive before enter the suspend mode.

The MTP805 send Resume signaling to USB bus when Susp=1 and RSMO=1. In the suspend mode, if a keyboard or mouse interrupt is asserted, S/W should send resume signal to wake up the USB bus.

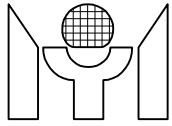

MEMORY MAP of XFR

Reg name	addr	bit7	bit6	bit5	Bit4	bit3	bit2	bit1	bit0	
USBADR	00h (r/w)	ENUSB	USBadr							
INTFLG0	01h (r/w)	RC0I	TX0I	TX1I	TX2I	RstI	SusI			
INTEN0	02h (w)	RC0IE	TX0IE	TX1IE	TX2IE	RstIE	SusIE			
INTFLG1	03h (r/w)						RsmI	KbdI	MsI	
INTEN1	04h (w)	PS2KB			FclKE		RsmIE	KbdIE	MsIE	
USBCTR	05h (r/w)	Susp	RsmO	EP1cfgd	EP2cfgd	RC0rdy	CtrRD			
EP0STUS	06h (r)	RC0tgl	RC0err	EP0dir	EP0set	RC0cnt				
TX0CTR	07h (r/w)	TX0rdy	TX0tgl	EP0stall		TX0cnt (write only)				
TX1CTR	08h (r/w)	TX1rdy	TX1tgl	EP1stall		TX1cnt (write only)				
TX2CTR	09h (r/w)	TX2rdy	TX2tgl	EP2stall		TX2cnt (write only)				
KSI	0Ah (r)	KSI7	KSI6	KSI5	KSI4	KSI3	KSI2	KSI1	KSI0	
LED	0Bh (r/w)					GPO0	LED2	LED1	LED0	
GPIO	0Ch (r/w)					GPIO1	GPIO0	KSO17	KSO16	
WDT	0Dh (w)	WDTen								
KSIMASK	0Eh (w)	KSImask7	KSImask6	KSImask5	KSImask4	KSImask3	KSImask2	KSImask1	KSImask0	
RC0FIFO	10h (r)	Endpoint 0 receive FIFO 1st byte								
RC0FIFO	11h (r)	Endpoint 0 receive FIFO 2nd byte								
RC0FIFO	12h (r)	Endpoint 0 receive FIFO 3rd byte								
RC0FIFO	13h (r)	Endpoint 0 receive FIFO 4th byte								
RC0FIFO	14h (r)	Endpoint 0 receive FIFO 5th byte								
RC0FIFO	15h (r)	Endpoint 0 receive FIFO 6th byte								
RC0FIFO	16h (r)	Endpoint 0 receive FIFO 7th byte								
RC0FIFO	17h (r)	Endpoint 0 receive FIFO 8th byte								
TX0FIFO	18h (w)	Endpoint 0 transmit FIFO 1st byte								
TX0FIFO	19h (w)	Endpoint 0 transmit FIFO 2nd byte								
TX0FIFO	1Ah (w)	Endpoint 0 transmit FIFO 3rd byte								
TX0FIFO	1Bh (w)	Endpoint 0 transmit FIFO 4th byte								
TX0FIFO	1Ch (w)	Endpoint 0 transmit FIFO 5th byte								
TX0FIFO	1Dh (w)	Endpoint 0 transmit FIFO 6th byte								
TX0FIFO	1Eh (w)	Endpoint 0 transmit FIFO 7th byte								
TX0FIFO	1Fh (w)	Endpoint 0 transmit FIFO 8th byte								
TX1FIFO	20h (w)	Endpoint 1 transmit FIFO 1st byte								
TX1FIFO	21h (w)	Endpoint 1 transmit FIFO 2nd byte								
TX1FIFO	22h (w)	Endpoint 1 transmit FIFO 3rd byte								
TX1FIFO	23h (w)	Endpoint 1 transmit FIFO 4th byte								
TX1FIFO	24h (w)	Endpoint 1 transmit FIFO 5th byte								
TX1FIFO	25h (w)	Endpoint 1 transmit FIFO 6th byte								
TX1FIFO	26h (w)	Endpoint 1 transmit FIFO 7th byte								
TX1FIFO	27h (w)	Endpoint 1 transmit FIFO 8th byte								
TX2FIFO	28h (w)	Endpoint 2 transmit FIFO 1st byte								
TX2FIFO	29h (w)	Endpoint 2 transmit FIFO 2nd byte								
TX2FIFO	2Ah (w)	Endpoint 2 transmit FIFO 3rd byte								
TX2FIFO	2Bh (w)	Endpoint 2 transmit FIFO 4th byte								
TX2FIFO	2Ch (w)	Endpoint 2 transmit FIFO 5th byte								
TX2FIFO	2Dh (w)	Endpoint 2 transmit FIFO 6th byte								
TX2FIFO	2Eh (w)	Endpoint 2 transmit FIFO 7th byte								
TX2FIFO	2Fh (w)	Endpoint 2 transmit FIFO 8th byte								

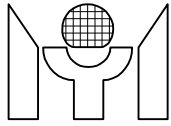

USBADR (r/w) : USB device address and enable.

ENUSB = 1 → Enable USB function, clear while chip reset.
USBadr : USB device address, clear while chip reset or USB bus reset.

INTFLG0 (w) : Interrupt flag. A interrupt event will set its individual flag, and, if the corresponding interrupt enable bit is set, the 8051's INT0 source will be driven by a zero level. Software MUST clear this register while serve the interrupt routine.

RC0I = 1 → No action.
= 0 → Clear RC0I flag.
TX0I = 1 → No action.
= 0 → Clear TX0I flag.
TX1I = 1 → No action.
= 0 → Clear TX1I flag.
TX2I = 1 → No action.
= 0 → Clear TX2I flag.
RstI = 1 → No action.
= 0 → Clear RstI flag.
SusI = 1 → No action.
= 0 → Clear SusI flag.

INTFLG0 (r) : Interrupt flag.

RC0I = 1 → Endpoint 0 has completed a receive transfer and save the data in RC0FIFO.
TX0I = 1 → Endpoint 0 has completed a transmit transfer and empty TX0FIFO.
TX1I = 1 → Endpoint 1 has completed a transmit transfer and empty TX1FIFO.
TX2I = 1 → Endpoint 2 has completed a transmit transfer and empty TX2FIFO.
RstI = 1 → Indicates the USB bus reset condition.
SusI = 1 → Indicates the USB bus suspend request (no bus activity for 3ms).

INTEN0 (w) : Interrupt enable.

RC0IE = 1 → Enable RC0I interrupt.
TX0IE = 1 → Enable TX0I interrupt.
TX1IE = 1 → Enable TX1I interrupt.
TX2IE = 1 → Enable TX2I interrupt.
RstIE = 1 → Enable RstI interrupt.
SusIE = 1 → Enable SusI interrupt.

INTFLG1 (w) : Interrupt flag. A interrupt event will set its individual flag, and, if the corresponding interrupt enable bit is set, the 8051's INT1 source will be driven by a zero level. Software MUST clear this register while serve the interrupt routine.

RsmI = 1 → No action.
= 0 → Clear RsmI flag.
KbdI = 1 → No action.
= 0 → Clear KbdI flag.
Msl = 1 → No action.
= 0 → Clear Msl flag.

INTFLG1 (r) : Interrupt flag.

RsmI = 1 → Indicates the USB bus RESUME condition in suspend mode.
KbdI = 1 → Indicates a low input has been detected on anyone of the KSI pins.
Msl = 1 → Indicates a low input has been detected on the MSCLK pin.

INTEN1 (w) : Interrupt enable.

PS2KB = 1 → Enable the pull up resistors on DP/PS2CLK and DM/PS2DATA pins.
FckE = 1 → Enable the CPU's faster clock, MUST be cleared before power-down.

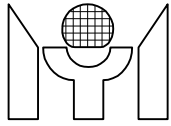

RsmIE = 1 → Enable RsmI interrupt.
KbdIE = 1 → Enable KbdI interrupt.
MslIE = 1 → Enable Msl interrupt.

USBCTR (r/w) : USB control register.

Susp = 1 → S/W force USB interface into suspend mode.
RsmO = 1 → S/W force USB interface send RESUME signal in suspend mode.
EP1cfgd = 1 → Endpoint 1 is configed.
EP2cfgd = 1 → Endpoint 2 is configed.
RC0rdy = 1 → Enable the Endpoint 0 to respond to OUT token.
= 0 → Endpoint 0 will respond NAK to OUT token.
This bit can be set or cleared by S/W, clear by H/W while RC0I occurs.
CtrRD = 1 → MTP805 will stall an invalid OUT token during Control Read transfer.

EP0STUS (r) : Endpoint 0 status.

RC0tgl = 1 → Receive a DATA1 packet.
= 0 → Receive a DATA0 packet.
RC0err = 1 → Receive DATA packet error.
= 0 → Receive DATA packet good.
EP0dir = 1 → Last transfer is transmit direction (IN).
= 0 → Last transfer is receive direction (OUT, SETUP).
EP0set = 1 → Last transfer is a SETUP.
= 0 → Last transfer is not a SETUP.
RC0cnt : Last transfer's receive byte count.

TX0CTR (r/w) : Endpoint 0 transmit control register.

TX0rdy = 1 → Enable the Endpoint 0 to respond to IN token.
= 0 → Endpoint 0 will respond NAK to IN token.
This bit can be set or cleared by S/W, clear by H/W while Host ack the transfer.
TX0tgl = 1 → Endpoint 0 will transmit DATA1 packet.
= 0 → Endpoint 0 will transmit DATA0 packet.
EP0stall = 1 → Endpoint 0 will stall OUT/IN packet.
TX0cnt (w) : Endpoint 0 transmit byte count, write only.

TX1CTR (r/w) : Endpoint 1 transmit control register.

TX1rdy = 1 → Enable the Endpoint 1 to respond to IN token.
= 0 → Endpoint 1 will respond NAK to IN token.
This bit can be set or cleared by S/W, clear by H/W while Host ack the transfer.
TX1tgl = 1 → Endpoint 1 will transmit DATA1 packet.
= 0 → Endpoint 1 will transmit DATA0 packet.
EP1stall = 1 → Endpoint 1 will stall IN packet.
TX1cnt (w) : Endpoint 1 transmit byte count, write only.

TX2CTR (r/w) : Endpoint 1 transmit control register.

TX2rdy = 1 → Enable the Endpoint 2 to respond to IN token.
= 0 → Endpoint 2 will respond NAK to IN token.
This bit can be set or cleared by S/W, clear by H/W while Host ack the transfer.
TX2tgl = 1 → Endpoint 2 will transmit DATA1 packet.
= 0 → Endpoint 2 will transmit DATA0 packet.
EP2stall = 1 → Endpoint 2 will stall IN packet.
TX2cnt (w) : Endpoint 1 transmit byte count, write only.

KSI (r) : KSI7~0's read result.

LED (w) : Data load into the GPO0 / LED2~0 output latch.

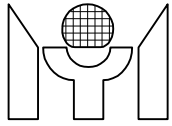

LED (r) : Data read from the GPO0 / LED2~0 output latch.

GPIO (w) : Data load into the GPIO1~0 / KSO17~16 output latch.

GPIO (r) : Data read from the GPIO1~0 / KSO17~16 pin.

WDT (w) : Write this register to clear Watch-Dog-Timer.
WDTen = 1 → Enable Watch-Dog-Timer.

KSIMASK (w) : Determine whether the key scan input can generate interrupt or not.
KSImask(n) = 1 → KSI(n) can not generate keyboard interrupt.
KSImask(n) = 0 → KSI(n) can generate keyboard interrupt.

RC0FIFO (r) : Endpoint 0 receive FIFO registers.

TX0FIFO (w) : Endpoint 0 transmit FIFO registers.

TX1FIFO (w) : Endpoint 1 transmit FIFO registers.

TX2FIFO (w) : Endpoint 2 transmit FIFO registers.

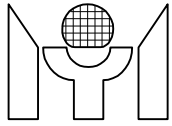

ELECTRICAL PARAMETERS

1. Absolute Maximum Ratings

at: Ta= 0 to 70 °C, VSS=0V

Name	Symbol	Range	Unit
Maximum Supply Voltage	VDD	-0.3 to +6.0	V
Maximum Input Voltage	Vin	-0.3 to VDD+0.3	V
Maximum Output Voltage	Vout	-0.3 to VDD+0.3	V
Maximum Operating Temperature	Topg	0 to +70	°C
Maximum Storage Temperature	Tstg	-25 to +125	°C

2. Allowable Operating Conditions

at: Ta= 0 to 70 °C, VSS=0V

Name	Symbol	Min.	Max.	Unit
Supply Voltage	VDD	4.5	5.5	V
Input "H" Voltage	Vih1	0.7 x VDD	VDD +0.3	V
Input "L" Voltage	Vil1	-0.3	0.15 x VDD	V
Operating Freq.	Fosc	6	6	MHz

3. DC Characteristics

at: Ta= 25 °C, VSS=0V, VDD=5V, Fosc=6MHz

Name	Symbol	Min.	Max.	Unit
Active current	Icc		6	mA
Power Down current	Ipd		20	uA
Output High Voltage @ Ioh=-100u	Voh	4.0		V
Output Low Voltage @ Iol=4mA	Vol		0.45	V
LED sink current @ Vol=3.2V	Iled	6.2		mA
RST pin pull down resistor	Rrst	50	150	Kohm
KSI pin pull up resistor	Rksi	50	100	Kohm
V33 output voltage	V33	3.2	3.4	V

4. AC Characteristics

at: Ta= 25 °C, VSS=0V, VDD=5V, Fosc=6MHz

Name	Symbol	Min.	Max.	Unit
DP/DM rise time	Trise	75	300	ns
DP/DM fall time	Tfall	75	300	ns
DP,DM cross point	Vx	1.3	2.0	V

* note: all USB transceiver characteristic can meet USB 1.1 spec

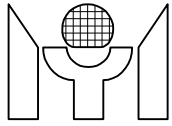

PACKAGE DIMENSION

1. 40-pin PDIP 600 mil

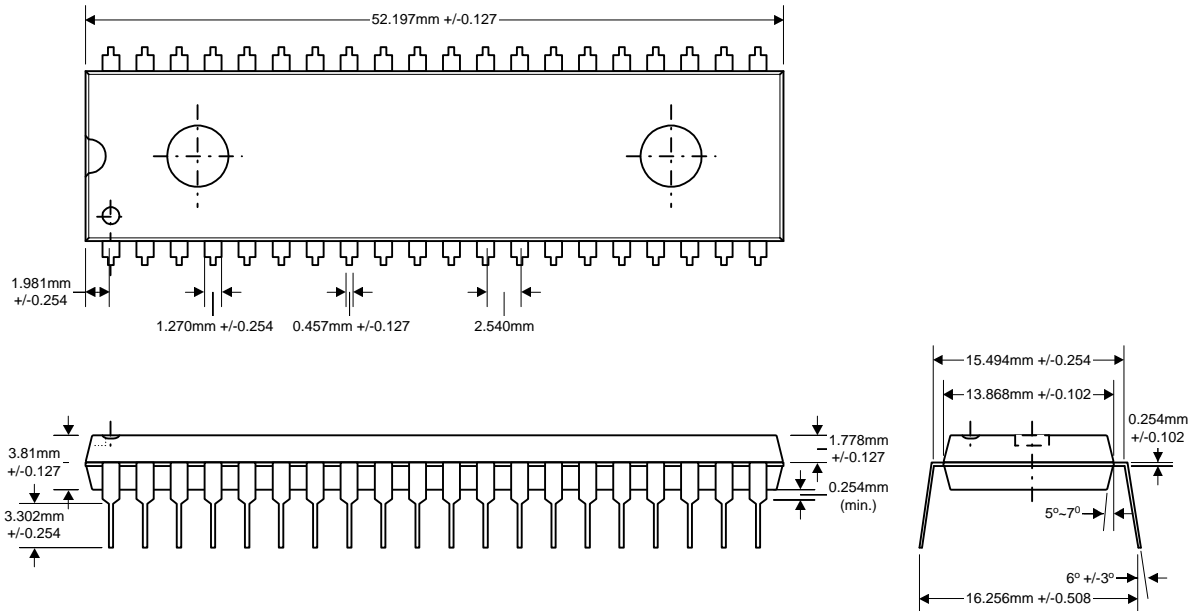

2. 42 pin SDIP Unit: mm

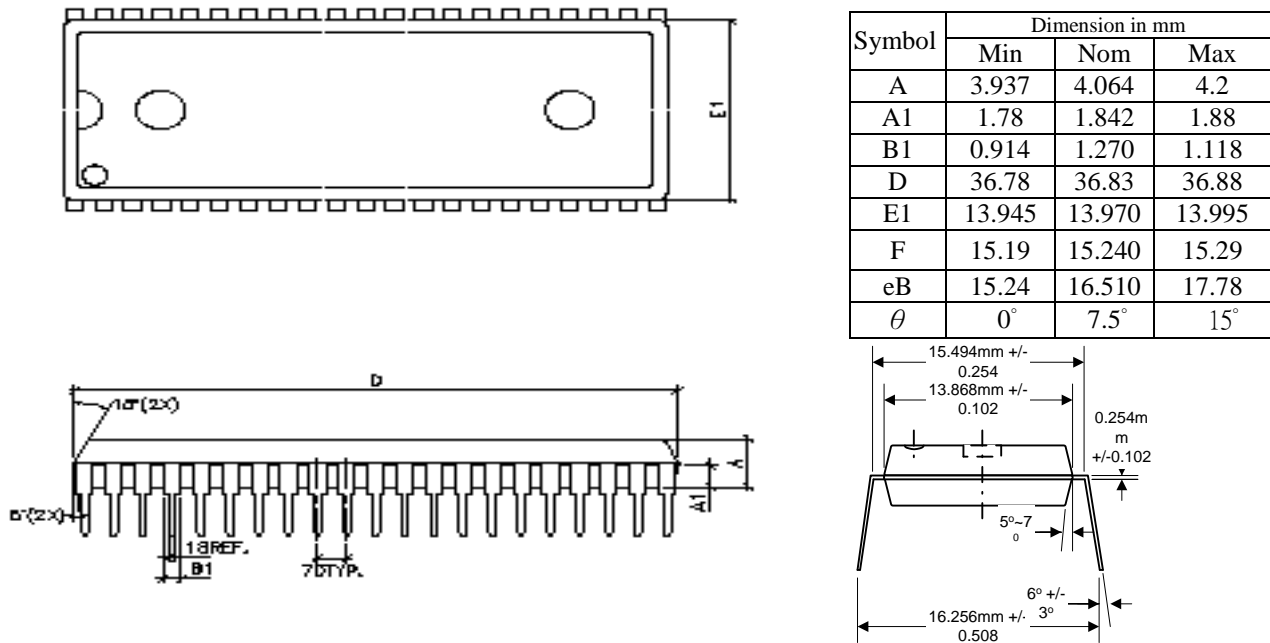

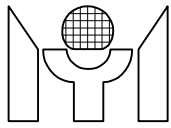

3. 44 pin PLCC Unit:

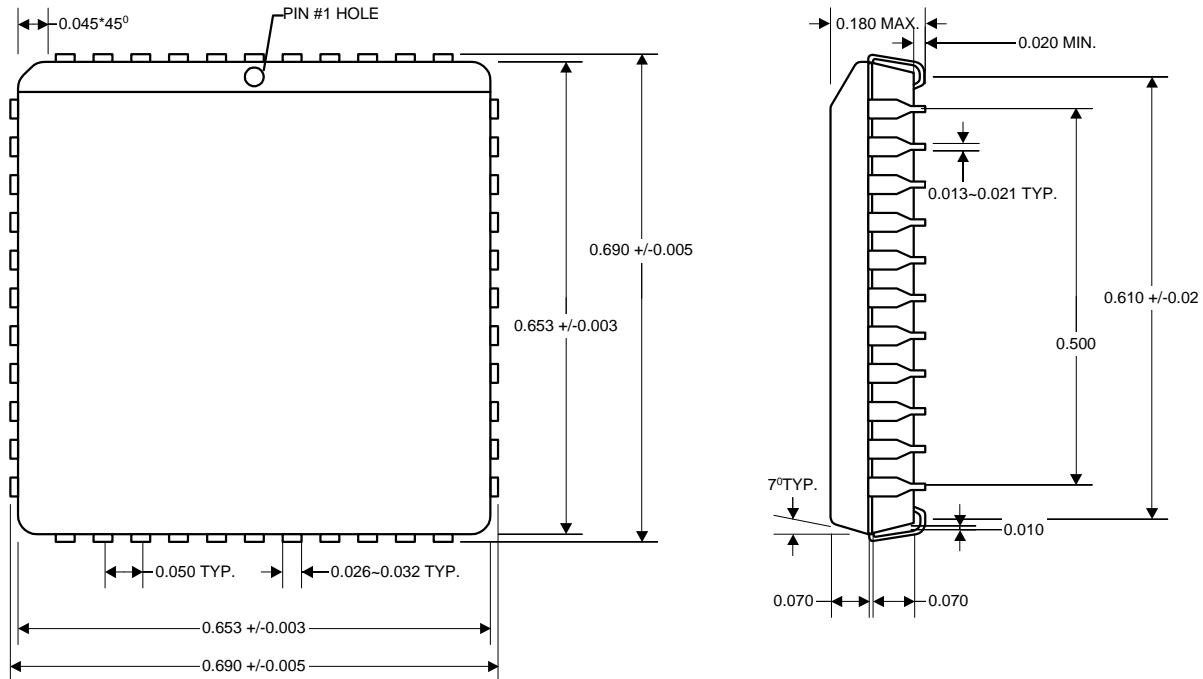

Ordering Information

Standard configurations:

Prefix	Part Type	Package Type
MTP	805	N: PDIP S: SDIP V: PLCC

Part Numbers:

Prefix	Part Type	Package Type
MTP	805	N
MTP	805	S
MTP	805	V