

FEATURES

- 2 contact arrangements
4 Form C (for 5 A 250 V AC),
2 Form C (for 7 A 250 V AC)
- Excellent contact reliability by Au plating
- Environmentally friendly Cd-free contacts
- Coil breakdown detection function (AC type with LED only)
- Convenient Screw terminal sockets with finger protection also available
- Test button type available
- Built-in diode and CR for surge suppression type available

TYPICAL APPLICATIONS

- Control panels
- Power supply units
- Molding machines
- Machine tools
- Welding equipment
- Agricultural equipment
- Office equipment
- Vending machines
- Communications equipment
- Amusement machines

ORDERING INFORMATION

Ex. HJ - - - - -

Contact arrangement	Operation indication	Test button	Coil voltage	Surge suppression	Contact surface
2: 2 Form C 4: 4 Form C	Nil: Without LED indication L: With LED indication	Nil: Without test button T: With test button	AC 12, 24, 48, 100, 120, 200, 220/240 V DC 12, 24, 48, 110 V	Nil: Without D: With diode R: With CR	Nil: Without 6: With Au plating

SPECIFICATIONS

Contacts

Arrangement		2 Form C	4 Form C
Initial contact resistance, max. (By voltage drop 6 V DC 1 A)		50mΩ	
Contact material		Au plating Silver alloy (Au plating type) Silver alloy (without Au plating type)	
Rating (resistive load)	Nominal switching capacity	7A 250V AC	5A 250V AC
	Max. switching power	1,750 VA	1,250 VA
	Max. switching voltage	250 V AC	
	Max. switching current	7 A	5 A
	Min. switching current* ⁹	1 V 1 mA	
Expected life (min. operations)	Mechanical (at 180 cpm)	2 × 10 ⁷	
	Electrical (at 20 cpm) (resistive load)	10 ⁵ (7A 250 V AC) 5 × 10 ⁵ (5A 250 V AC)	10 ⁵ (5A 250 V AC) 2 × 10 ⁵ (3A 250 V AC)

Coil

Nominal operating power	0.9W 1.2V A
-------------------------	-------------

Remarks

- * Specifications will vary with foreign standards certification ratings.
- ¹ Measurement at same location as "Initial breakdown voltage" section
- ² Detection current: 10mA
- ³ Excluding contact bounce time
- ⁴ For the AC coil types, the operate/release time will differ depending on the phase.
- ⁵ Half-wave pulse of sine wave: 11ms; detection time: 10μs
- ⁶ Half-wave pulse of sine wave: 6ms
- ⁷ Detection time: 10μs
- ⁸ Refer to 4. Conditions for operation, transport and storage mentioned in NOTES
- ⁹ This value can change due to the switching frequency, environmental conditions and desired reliability level, therefore it is recommended to check this with the actual load.

Characteristics

		2 Form C	4 Form C
Max. operating speed		20 cpm (at max. rating)	
Initial insulation resistance* ¹		Min. 100 MΩ at 500 V DC	
Initial breakdown voltage* ²	Between open contacts	1,000 Vrms for 1 min.	
	Between contact sets	2,000 Vrms for 1 min.	
	Between contact and coil	2,000 Vrms for 1 min.	
Operate time* ³ (at nominal voltage)		Max. 20 ms* ⁴	
Release time (without diode)* ³ (at nominal voltage)		Max. 20 ms* ⁴	
Temperature rise, max. (at 70°C) (at nominal voltage)		60°C	
Shock resistance	Functional* ⁵	Min. 100 m/s ² {10 G}	
	Destructive* ⁶	Min. 1,000 m/s ² {100 G}	
Vibration resistance	Functional* ⁷	10 to 55 Hz at double amplitude of 1.0 mm	
	Destructive	10 to 55 Hz at double amplitude of 1.0 mm	
Conditions for operation, transport and storage* ⁸ (Not freezing and condensing at low temperature)	Ambient temp.	-40°C to +70°C -40°F to +158°F	
	Humidity	5 to 85% R.H.	
Unit weight	Without test button	Approx. 31g 1.09 oz	Approx. 32g 1.13 oz
	Test button	Approx. 34g 1.20 oz	Approx. 34g 1.20 oz

HJ RELAY
ASCT1B259E '03.2

TYPES

[Au plating type]

1. Plug-in type

Coil voltage	2 Form C	4 Form C
	Part No.	Part No.
12V DC	HJ2-DC 12V-6	HJ4-DC 12V-6
24V DC	HJ2-DC 24V-6	HJ4-DC 24V-6
48V DC	HJ2-DC 48V-6	HJ4-DC 48V-6
110V DC	HJ2-DC110V-6	HJ4-DC110V-6
12V AC	HJ2-AC 12V-6	HJ4-AC 12V-6
24V AC	HJ2-AC 24V-6	HJ4-AC 24V-6
48V AC	HJ2-AC 48V-6	HJ4-AC 48V-6
100V AC	HJ2-AC100V-6	HJ4-AC100V-6
120V AC	HJ2-AC120V-6	HJ4-AC120V-6
200V AC	HJ2-AC200V-6	HJ4-AC200V-6
220/240V AC	HJ2-AC220/240V-6	HJ4-AC220/240V-6

3. Plug-in type (with diode)

Coil voltage	2 Form C	4 Form C
	Part No.	Part No.
12V DC	HJ2-DC 12V-D-6	HJ4-DC 12V-D-6
24V DC	HJ2-DC 24V-D-6	HJ4-DC 24V-D-6
48V DC	HJ2-DC 48V-D-6	HJ4-DC 48V-D-6
110V DC	HJ2-DC110V-D-6	HJ4-DC110V-D-6

5. Plug-in type (with CR)

Coil voltage	2 Form C	4 Form C
	Part No.	Part No.
100V AC	HJ2-AC100V-R-6	HJ4-AC100V-R-6
120V AC	HJ2-AC120V-R-6	HJ4-AC120V-R-6
200V AC	HJ2-AC200V-R-6	HJ4-AC200V-R-6
220/240V AC	HJ2-AC220/240V-R-6	HJ4-AC220/240V-R-6

(Note) Packing quantity: 20pcs. (Inner carton), 200pcs. (Outer carton)

[Without Au plating type]

1. Plug-in type

Coil voltage	2 Form C	4 Form C
	Part No.	Part No.
12V DC	HJ2-DC 12V	HJ4-DC 12V
24V DC	HJ2-DC 24V	HJ4-DC 24V
48V DC	HJ2-DC 48V	HJ4-DC 48V
110V DC	HJ2-DC110V	HJ4-DC110V
12V AC	HJ2-AC 12V	HJ4-AC 12V
24V AC	HJ2-AC 24V	HJ4-AC 24V
48V AC	HJ2-AC 48V	HJ4-AC 48V
100V AC	HJ2-AC100V	HJ4-AC100V
120V AC	HJ2-AC120V	HJ4-AC120V
200V AC	HJ2-AC200V	HJ4-AC200V
220/240V AC	HJ2-AC220/240V	HJ4-AC220/240V

3. Plug-in type (with test button)

Coil voltage	2 Form C	4 Form C
	Part No.	Part No.
12V DC	HJ2-T-DC 12V	HJ4-T-DC 12V
24V DC	HJ2-T-DC 24V	HJ4-T-DC 24V
48V DC	HJ2-T-DC 48V	HJ4-T-DC 48V
110V DC	HJ2-T-DC110V	HJ4-T-DC110V
12V AC	HJ2-T-AC 12V	HJ4-T-AC 12V
24V AC	HJ2-T-AC 24V	HJ4-T-AC 24V
48V AC	HJ2-T-AC 48V	HJ4-T-AC 48V
100V AC	HJ2-T-AC100V	HJ4-T-AC100V
120V AC	HJ2-T-AC120V	HJ4-T-AC120V
200V AC	HJ2-T-AC200V	HJ4-T-AC200V
220/240V AC	HJ2-T-AC220/240V	HJ4-T-AC220/240V

2. Plug-in type (with LED indication)

Coil voltage	2 Form C	4 Form C
	Part No.	Part No.
12V DC	HJ2-L-DC 12V-6	HJ4-L-DC 12V-6
24V DC	HJ2-L-DC 24V-6	HJ4-L-DC 24V-6
48V DC	HJ2-L-DC 48V-6	HJ4-L-DC 48V-6
110V DC	HJ2-L-DC110V-6	HJ4-L-DC110V-6
12V AC	HJ2-L-AC 12V-6	HJ4-L-AC 12V-6
24V AC	HJ2-L-AC 24V-6	HJ4-L-AC 24V-6
48V AC	HJ2-L-AC 48V-6	HJ4-L-AC 48V-6
100V AC	HJ2-L-AC100V-6	HJ4-L-AC100V-6
120V AC	HJ2-L-AC120V-6	HJ4-L-AC120V-6
200V AC	HJ2-L-AC200V-6	HJ4-L-AC200V-6
220/240V AC	HJ2-L-AC220/240V-6	HJ4-L-AC220/240V-6

4. Plug-in type (with diode and LED indication)

Coil voltage	2 Form C	4 Form C
	Part No.	Part No.
12V DC	HJ2-L-DC 12V-D-6	HJ4-L-DC 12V-D-6
24V DC	HJ2-L-DC 24V-D-6	HJ4-L-DC 24V-D-6
48V DC	HJ2-L-DC 48V-D-6	HJ4-L-DC 48V-D-6
110V DC	HJ2-L-DC110V-D-6	HJ4-L-DC110V-D-6

6. Plug-in type (with CR and LED indication)

Coil voltage	2 Form C	4 Form C
	Part No.	Part No.
100V AC	HJ2-L-AC100V-R-6	HJ4-L-AC100V-R-6
120V AC	HJ2-L-AC120V-R-6	HJ4-L-AC120V-R-6
200V AC	HJ2-L-AC200V-R-6	HJ4-L-AC200V-R-6
220/240V AC	HJ2-L-AC220/240V-R-6	HJ4-L-AC220/240V-R-6

2. Plug-in type (with LED indication)

Coil voltage	2 Form C	4 Form C
	Part No.	Part No.
12V DC	HJ2-L-DC 12V	HJ4-L-DC 12V
24V DC	HJ2-L-DC 24V	HJ4-L-DC 24V
48V DC	HJ2-L-DC 48V	HJ4-L-DC 48V
110V DC	HJ2-L-DC110V	HJ4-L-DC110V
12V AC	HJ2-L-AC 12V	HJ4-L-AC 12V
24V AC	HJ2-L-AC 24V	HJ4-L-AC 24V
48V AC	HJ2-L-AC 48V	HJ4-L-AC 48V
100V AC	HJ2-L-AC100V	HJ4-L-AC100V
120V AC	HJ2-L-AC120V	HJ4-L-AC120V
200V AC	HJ2-L-AC200V	HJ4-L-AC200V
220/240V AC	HJ2-L-AC220/240V	HJ4-L-AC220/240V

4. Plug-in type (with LED indication and test button)

Coil voltage	2 Form C	4 Form C
	Part No.	Part No.
12V DC	HJ2-L-T-DC 12V	HJ4-L-T-DC 12V
24V DC	HJ2-L-T-DC 24V	HJ4-L-T-DC 24V
48V DC	HJ2-L-T-DC 48V	HJ4-L-T-DC 48V
110V DC	HJ2-L-T-DC110V	HJ4-L-T-DC110V
12V AC	HJ2-L-T-AC 12V	HJ4-L-T-AC 12V
24V AC	HJ2-L-T-AC 24V	HJ4-L-T-AC 24V
48V AC	HJ2-L-T-AC 48V	HJ4-L-T-AC 48V
100V AC	HJ2-L-T-AC100V	HJ4-L-T-AC100V
120V AC	HJ2-L-T-AC120V	HJ4-L-T-AC120V
200V AC	HJ2-L-T-AC200V	HJ4-L-T-AC200V
220/240V AC	HJ2-L-T-AC220/240V	HJ4-L-T-AC220/240V

5. Plug-in type (with diode)

Coil voltage	2 Form C	4 Form C
	Part No.	Part No.
12V DC	HJ2-DC 12V-D	HJ4-DC 12V-D
24V DC	HJ2-DC 24V-D	HJ4-DC 24V-D
48V DC	HJ2-DC 48V-D	HJ4-DC 48V-D
110V DC	HJ2-DC110V-D	HJ4-DC110V-D

6. Plug-in type (with diode and LED indication)

Coil voltage	2 Form C	4 Form C
	Part No.	Part No.
12V DC	HJ2-L-DC 12V-D	HJ4-L-DC 12V-D
24V DC	HJ2-L-DC 24V-D	HJ4-L-DC 24V-D
48V DC	HJ2-L-DC 48V-D	HJ4-L-DC 48V-D
110V DC	HJ2-L-DC110V-D	HJ4-L-DC110V-D

7. Plug-in type (with CR)

Coil voltage	2 Form C	4 Form C
	Part No.	Part No.
100V AC	HJ2-AC100V-R	HJ4-AC100V-R
120V AC	HJ2-AC120V-R	HJ4-AC120V-R
200V AC	HJ2-AC200V-R	HJ4-AC200V-R
220/240V AC	HJ2-AC220/240V-R	HJ4-AC220/240V-R

8. Plug-in type (with CR and LED indication)

Coil voltage	2 Form C	4 Form C
	Part No.	Part No.
100V AC	HJ2-L-AC100V-R	HJ4-L-AC100V-R
120V AC	HJ2-L-AC120V-R	HJ4-L-AC120V-R
200V AC	HJ2-L-AC200V-R	HJ4-L-AC200V-R
220/240V AC	HJ2-L-AC220/240V-R	HJ4-L-AC220/240V-R

Note) Packing quantity: 20pcs. (Inner carton), 200pcs. (Outer carton)

[Accessories]

Type	No. of channels	Item	Part No.
Terminal socket	2 channels	HJ2 terminal socket	HJ2-SFD
		HJ2 terminal socket (Finger protect type)	HJ2-SFD-S
	2/4 channels (common)	HJ4 terminal socket	HJ4-SFD
		HJ4 terminal socket (Finger protect type)	HJ4-SFD-S

- Notes) 1. Packing quantity: 10pcs. (Inner carton), 100pcs. (Outer carton)
 2. Use the retainer that is shipped with the terminal socket.
 3. Products conform to UL, CSA and TÜV, as standard.
 4. In order to prevent breakage and disfiguring, the screw tightening torque for the terminal socket should be within the range of 0.5 to 0.8 N•m.
 5. When attaching directly to a chassis, please use an M3.5 × 0.6 metric coarse screw thread, a spring washer, and a hexagonal nut.
 6. For S1DX timer, use the retainer (Part No. ADX18012).

COIL DATA

DC coils

Coil voltage V DC	Pick-up voltage, V DC (max.) (at 20°C 68°F) (Initial)	Drop-out voltage, V DC (max.) (at 20°C 68°F) (Initial)	Nominal coil current, mA (±20%)	Coil resistance, Ω (at 20°C 68°F) (±20%)	Nominal operating power, W (±20%)	Max. allowable voltage, V DC (at 70°C 158°F)
12	9.6	1.2	75	160 (±10%)	0.9	13.2
24	19.2	2.4	37	650 (±10%)	0.9	26.4
48	38.4	4.8	18	2,600 (±15%)	0.9	52.8
110	88	11	10	11,000 (±15%)	1.1	121

AC coils (50/60Hz)

Coil voltage V AC	Pick-up voltage, V AC (max.) (at 20°C 68°F) (Initial)	Drop-out voltage, V AC (max.) (at 20°C 68°F) (Initial)	Nominal coil current, mA (±20%)		Nominal operating power, V A (±20%)		Max. allowable voltage, V AC (at 70°C 158°F)
			50Hz	60Hz	50Hz	60Hz	
12	9.6	3.6	102.9	85.4	Approx. 1.2 to 1.5	Approx. 1.0 to 1.3	13.2
24	19.2	7.2	54.5	45.6			26.4
48	38.4	14.4	30.7	25.9			52.8
100	80	30	11.8	10.0			110
120	96	36	12.5	10.3			132
200	160	60	6.8	5.7			220
220/240	176	72	6.8/7.8	5.6/6.4	264		

DIMENSIONS

mm inch

1. Plug-in type 2 Form C (including diode/CR)

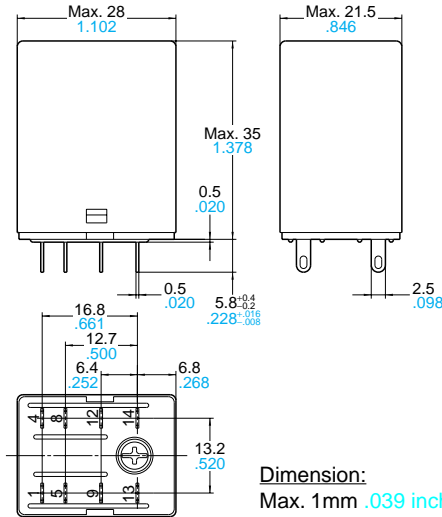

Dimension:
 Max. 1mm **.039 inch:**
 1 to 3mm **.039 to .118 inch:**
 Min. 3mm **.118 inch:**

Tolerance
 $\pm 0.1 \pm .004$
 $\pm 0.2 \pm .008$
 $\pm 0.3 \pm .012$

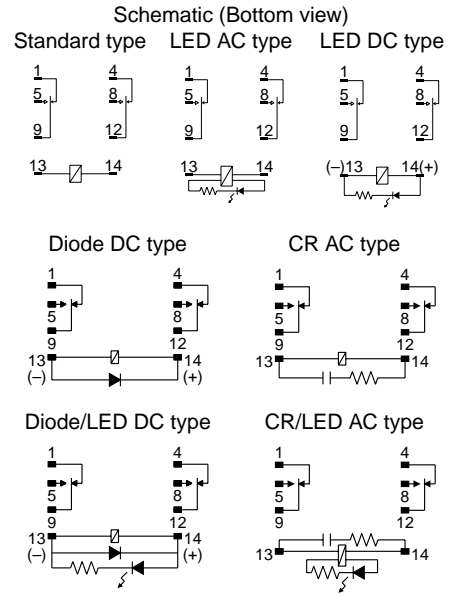

2. Plug-in type 4 Form C (including diode/CR)

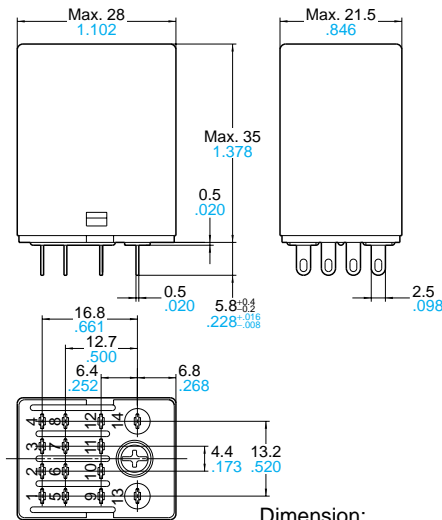

Dimension:
 Max. 1mm **.039 inch:**
 1 to 3mm **.039 to .118 inch:**
 Min. 3mm **.118 inch:**

Tolerance
 $\pm 0.1 \pm .004$
 $\pm 0.2 \pm .008$
 $\pm 0.3 \pm .012$

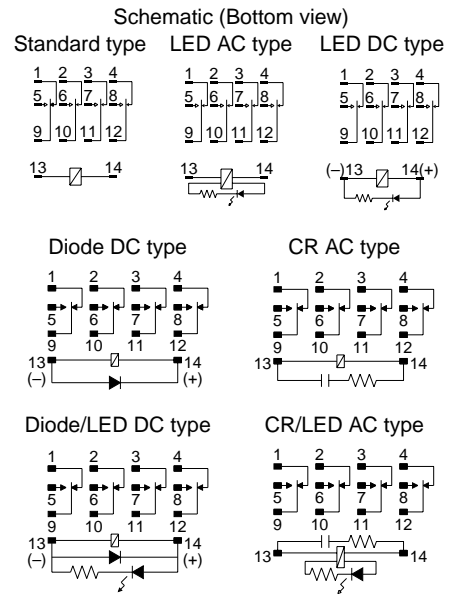

3. Plug-in type with test button 2 Form C

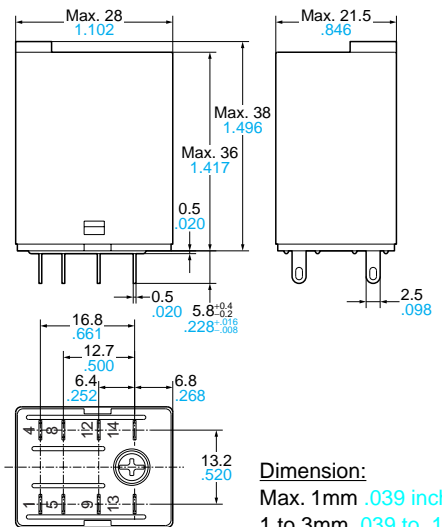

Dimension:
 Max. 1mm **.039 inch:**
 1 to 3mm **.039 to .118 inch:**
 Min. 3mm **.118 inch:**

Tolerance
 $\pm 0.1 \pm .004$
 $\pm 0.2 \pm .008$
 $\pm 0.3 \pm .012$

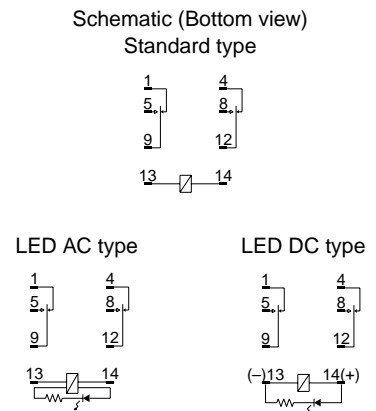

4. Plug-in type with test button 4 Form C

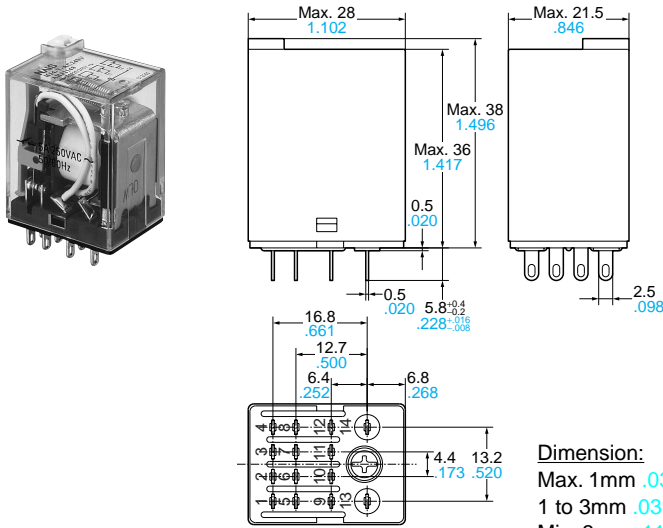

Schematic (Bottom view)
Standard type

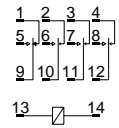

LED AC type

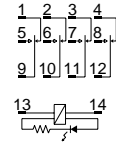

LED DC type

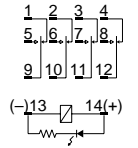

5. Terminal socket
HJ2 terminal socket

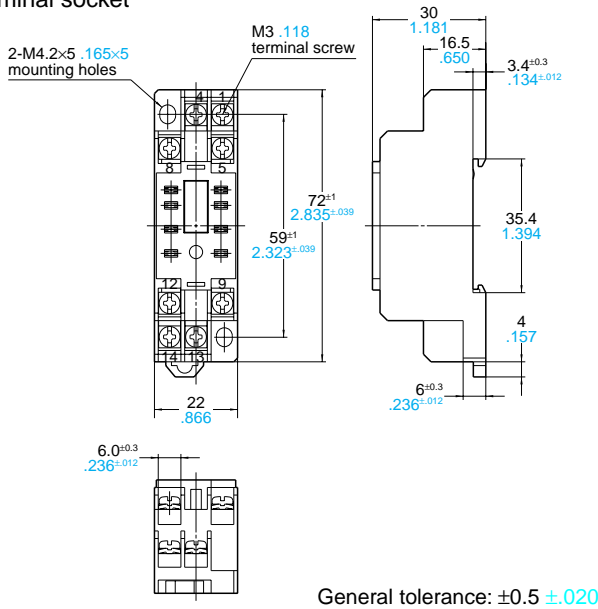

Schematic (Bottom view)

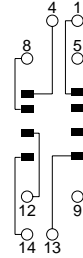

Mounting hole dimensions

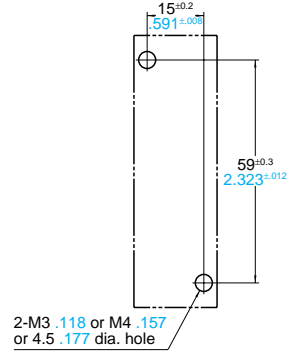

HJ2 terminal socket (Finger protect type)

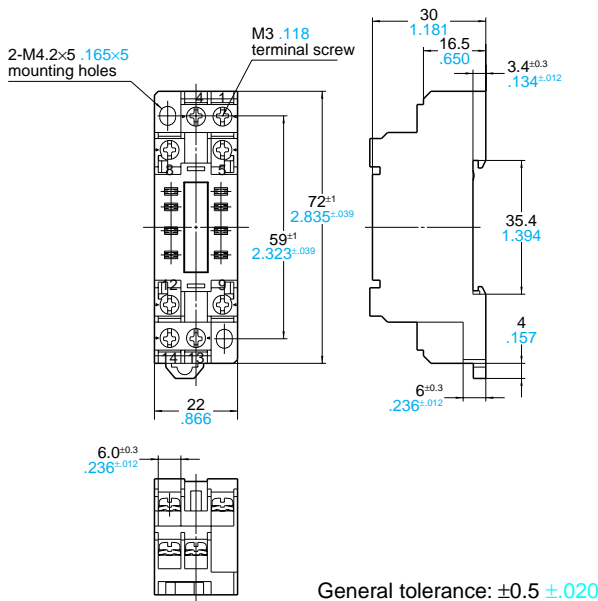

Schematic (Bottom view)

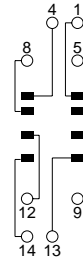

Mounting hole dimensions

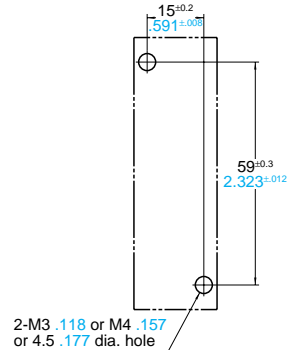

Note) Round type terminal is unable to attach.

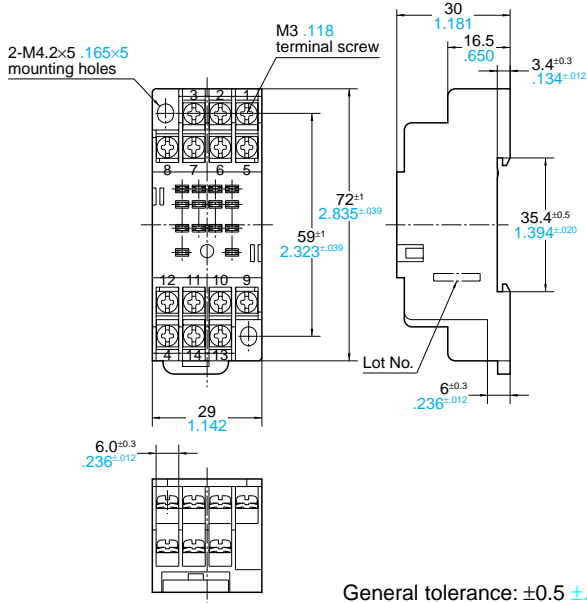

Schematic (Bottom view)

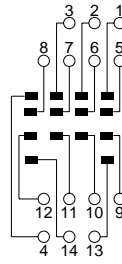

Mounting hole dimensions

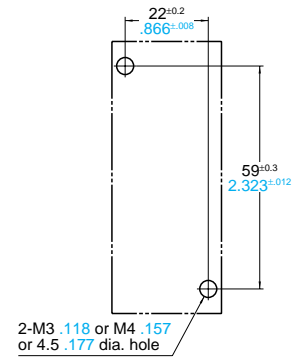

HJ4 terminal socket (Finger protect type)

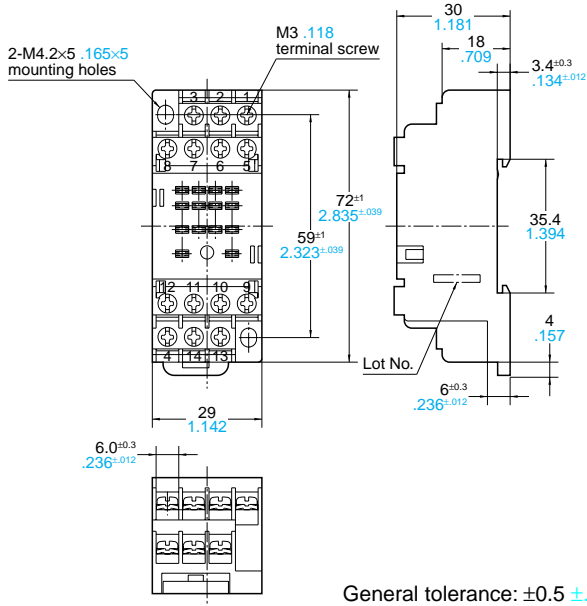

Schematic (Bottom view)

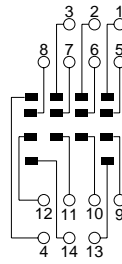

Mounting hole dimensions

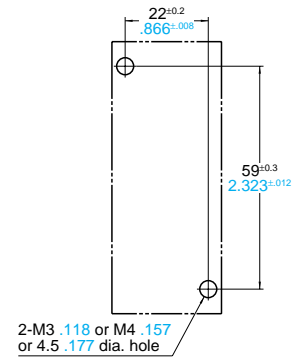

Note) Round type terminal is unable to attach.

REFERENCE DATA

1-(1). Max. switching capacity (2 Form C type)

1-(2). Max. switching capacity (4 Form C type)

2-(1). Coil temperature rise (2 Form C/AC type)

Measured portion: Inside the coil
Ambient temperature: 70°C 158°F

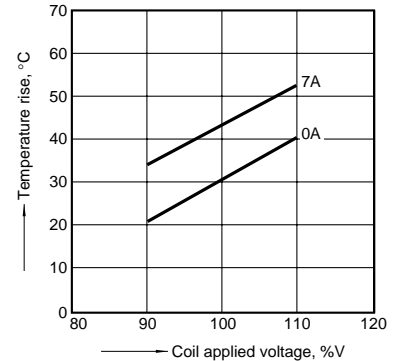
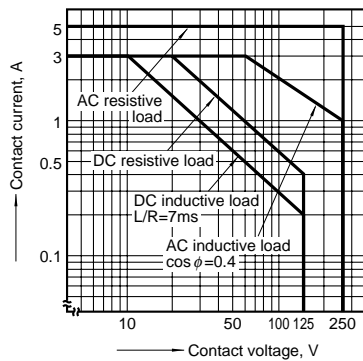
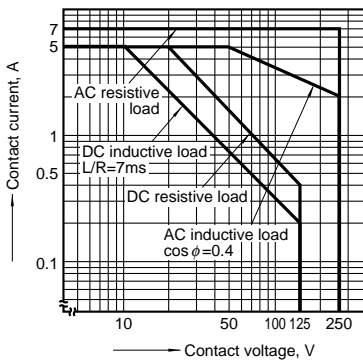

2-(2). Coil temperature rise (2 Form C/DC type)

Measured portion: Inside the coil
Ambient temperature: 70°C 158°F

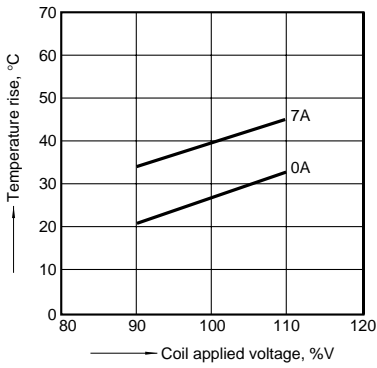

2-(3). Coil temperature rise (4 Form C/AC type)

Measured portion: Inside the coil
Ambient temperature: 70°C 158°F

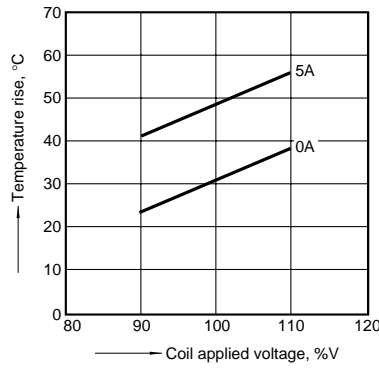

2-(4). Coil temperature rise (4 Form C/DC type)

Measured portion: Inside the coil
Ambient temperature: 70°C 158°F

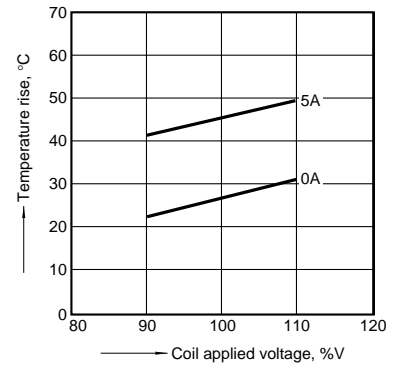

3-(1). AC coil surge voltage waveform (With CR)

Tested sample: HJ4-AC200V-R

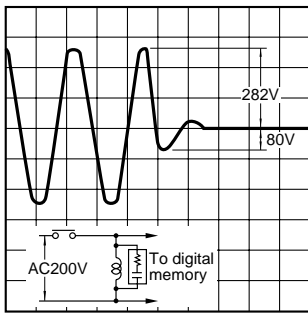

3-(2). AC coil surge voltage waveform (Without CR)

Tested sample: HJ4-AC200V

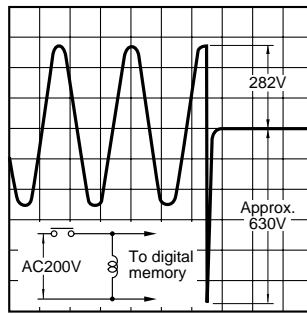

4-(1). DC coil surge voltage waveform (Without diode)

(Without diode)

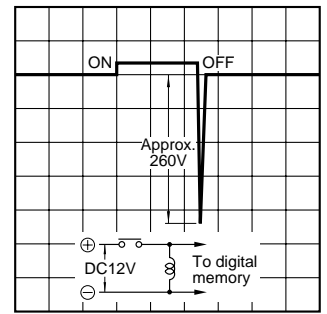

4-(2). DC coil surge voltage waveform (With diode)

Diode characteristics:
Reverse breakdown voltage: 1,000 V
Forward current: 1 A

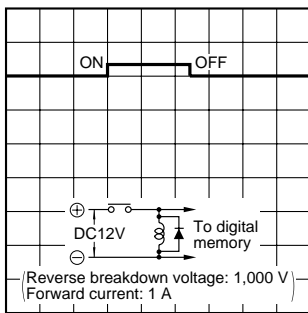

NOTES

1. Coil operating power

To ensure proper operation, the voltage applied to both terminals of the coil should be $\pm 5\%$ (at 20°C 68°F) the rated operating voltage of the coil. Also, be aware that the pick-up and drop-out voltages will fluctuate depending on the ambient temperature and operating conditions.

2. LED indications

The light of the light emitting diode is what displays operation. If voltage remains after relay dropout, the LED might illuminate briefly.

3. Switching lifetime

The switching lifetime is defined under the standard test condition specified in the JIS* C 5442-1996 standard (temperature 15 to 35°C 59 to 95°F, humidity 25 to 75%). Check this with the real device as it is affected by coil driving circuit, load type, activation frequency, activation phase, ambient conditions and other factors. Also, be especially careful of loads such as those listed below.

(1) When used for AC load-operating and the operating phase is synchronous. Rocking and fusing can easily occur due to contact shifting.

(2) High-frequency load-operating
When high-frequency opening and closing of the relay is performed with a load that causes arcs at the contacts, nitrogen and oxygen in the air is fused by the arc energy and HNO_3 is formed. This can corrode metal materials.

Three countermeasures for these are listed here.

- (1) Incorporate an arc-extinguishing circuit.
- (2) Lower the operating frequency
- (3) Lower the ambient humidity

4. Conditions for operation, transport and storage

1) Ambient temperature, humidity, and atmospheric pressure during usage, transport, and storage of the relay:

- (1) Temperature:
-40 to +70°C -40 to +158°F
- (2) Humidity: 5 to 85% RH

(Avoid freezing and condensation.)

The humidity range varies with the temperature. Use within the range indicated in the graph below.

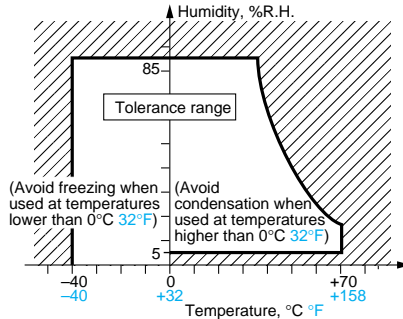

- (3) Atmospheric pressure: 86 to 106 kPa
Temperature and humidity range for usage, transport, and storage:

2) Condensation

Condensation forms when there is a sudden change in temperature under high temperature and high humidity conditions. Condensation will cause deterioration of the relay insulation.

3) Freezing

Condensation or other moisture may freeze on the relay when the temperatures is lower than 0°C 32°F. This causes problems such as sticking of movable parts or operational time lags.

4) Low temperature, low humidity environments

The plastic becomes brittle if the relay is exposed to a low temperature, low humidity environment for long periods of time.

5. Screwing torque of pressure screw block should be less than 0.5 to 0.8N·m to avoid breaking heads and bodies.**6. Take care not to touch the button during normal usage to prevent unexpected switching. Test button should be used only to check the circuit connection.****7. Operation method for test button**

- 1) Push and release ① gently to confirm relay switching.

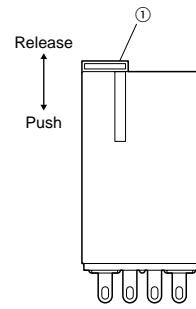

- 2) To lock to one side turn 90° counter-clockwise while pushing lock and turn 90° clockwise to release.

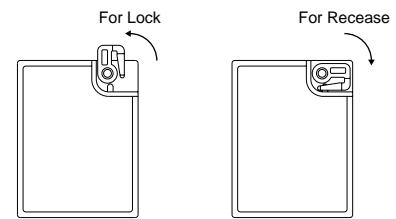
**8. Rating**

Standard	File No.	Ratings	
		2 Form C	4 Form C
UL	E43149	7A 250 V AC 7A 30V DC	5A 250 V AC 5A 30V DC
TÜV	Std. type R 2024382		
	Test button R 2-50006950	7A 250 V~ (cosφ=1) 7A 30V... (0ms)	5A 250 V~ (cosφ=1) 5A 30V... (0ms)
	CR, Diode Au plating R 50006950		

9. Diode characteristics

- 1) Reverse breakdown voltage: 1,000 V
- 2) Forward current: 1 A

10. Diode and CR built-in type

Since the diode and CR inside the relay coil are designed to absorb the counter emf, the element may be damaged if a large surge, etc., is applied to the diode and CR. If there is the possibility of a large surge voltage from the outside, please implement measures to absorb it.