

NAIS

UNIQUELY DESIGNED RELAY

K-RELAYS

FEATURES

- 100 times more reliable than similar designs
- Extra long life — Mechanical: more than 10⁸ operations
Electrical (1 A 30 V): more than 10⁶ operations
- Versatile range for all applications

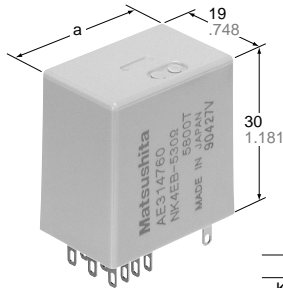

mm inch

	a	
K2EB	23.6	0.929
K4EB	29.4	1.157
K6EB	34.8	1.370

Sealed construction

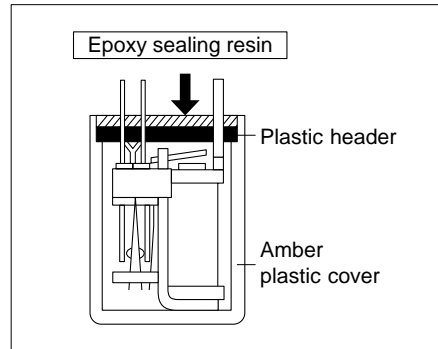

Gold-clad bifurcated contacts

Low and stable contact resistance
Low level current switching possible

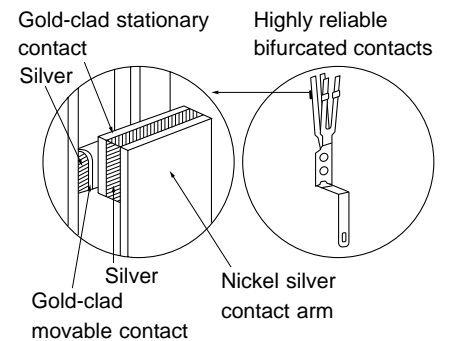

SPECIFICATIONS

Contacts

Arrangement		2, 4, 6 Form C
Rating (resistive load)	Max. switching power	50 W, 100 VA
	Max. switching voltage	220 V AC DC
	Max. switching current	2A
Expected life (min. operations)	Mechanical	10 ⁸
	Electrical (1 A 100 V AC)	10 ⁶
Contact material (Bifurcated contacts)	Movable contact	Gold-clad silver
	Stationary contact	Gold-clad silver
Initial contact resistance, max. (By voltage drop 6 V DC 1 A)		50 mΩ
Capacitance	Contact/Contact	3 pF
	Contact/Ground	5 pF

Characteristics (at 20°C 68°F, 50% R.H.)

Max. operating speed		50 cps.
Initial insulation resistance		Min. 1,000 MΩ at 500 V DC
Initial break-down voltage	Between open contacts, contact sets	750 Vrms
	Between live parts and ground	750 Vrms
	Between contacts and coil	750 Vrms
Operate time*1 (at nominal voltage)		Approx. 15 ms
Release time*1 (at nominal voltage)		Approx. 5 ms
Vibration resistance		98 m/s ² {10 G}, 10 to 55 Hz at double amplitude of 1.6 mm
Shock resistance		98 m/s ² {10 G}
Conditions for operation, transport and storage (Not freezing and condensing at low temperature)	Ambient temperature*2	2C, 4C: -40°C to +60°C -40°F to +140°F 6C: -40°C to +40°C -40°F to +104°F
	Humidity	5 to 85% R.H.
Ambient pressure		101, 325 Pa ±20% {1,013 mb ±20%}
Unit weight (approx.)		K2EB: 23 g .81 oz, K4EB: 27 g .95 oz, K6EB: 30 g 1.06 oz

*1 Excluding contact bounce time

*2 Total temperature (temperature rise in coil plus ambient temperature) should be kept less than max. 115°C 221°F

ORDERING INFORMATION

Ex. K 2 EB P — 24V — 1

Contact arrangement	Type classification	Terminal	Coil (DC)	Sensitivity
2: 2 Form C 4: 4 Form C 6: 6 Form C	EB: Amber sealed type	Nil: Plug-in, solder terminal P: PC board terminal	3 to 110 V	Nil: High sensitivity relays 1: Ordinary sensitive relays

(Notes) 1. Other coil and contact specifications are available on request for orders of more than 1,000 pcs.

Please state: Required coil resistance Gold clad/Gold clad contacts

2. For UL/CSA or VDE recognized types, and suffix UL/CSA or VDE.

3. Standard packing Carton: 20 pcs. Case: 200 pcs.

TYPICAL APPLICATIONS

Typical applications include:

Systems and equipment requiring higher reliability, Severe environmental uses, Alarm devices, Office machines, Telecommunication equipment, Pollution control equipment

TYPES AND COIL DATA

Part No.		Coil voltage (V)					Coil resistance* (Ω at 20°C)	Nominal coil power (mW)	Inductance (H)	
Plug-in and Solder	For PC board	Nominal (DC)	Pick-up (max. at 20°C)	Drop-out (min. at 20°C)	Max. allowable voltage, (at 40°C)	Armature				
						Closed			Open	
2 Form C	K2EB-3V-1	K2EBP-3V-1	3	1.8	0.27	6.7	28	320	0.52	0.26
	K2EB-6V-1	K2EBP-6V-1	6	3.9	0.58	12.0	110	330	2.1	1.1
	K2EB-12V-1	K2EBP-12V-1	12	8.0	1.2	30.0	530	270	11	5.6
	K2EB-24V-1	K2EBP-24V-1	24	16.5	2.5	47.0	1,700	340	35	18
	K2EB-42V-1	K2EBP-42V-1	42	30.0	4.5	72.0	5,300	333	95	48
	K2EB-48V-1	K2EBP-48V-1	48	39.0	5.9	100.0	7,600	300	120	62
	K2EB-110V-1	K2EBP-110V-1	110	60.0	9.0	180.0	16,000	760	270	138
4 Form C	K4EB-3V-1	K4EBP-3V-1	3	2.3	0.35	5.0	18	500	0.36	0.18
	K4EB-6V-1	K4EBP-6V-1	6	4.2	0.63	9.0	58	620	1.0	0.5
	K4EB-12V-1	K4EBP-12V-1	12	8.7	1.3	18.5	250	580	5.2	2.6
	K4EB-24V-1	K4EBP-24V-1	24	18.0	2.7	35.0	890	650	15	7.5
	K4EB-28V-1	K4EBP-28V-1	28	19.0	2.85	33.0	1,100	713	20	11
	K4EB-48V-1	K4EBP-48V-1	48	36.0	5.4	64.0	3,200	720	54	28
	K4EB-110V-1	K4EBP-110V-1	110	85.0	12.8	160.0	16,000	760	270	138
6 Form C	K6EB-6V		6	4.2	0.63	6.6	28	1,286	0.52	0.26
	K6EB-12V		12	8.4	1.26	13.2	110	1,309	2.1	1.1
	K6EB-24V		24	16.8	2.52	26.4	440	1,309	8.3	4.2
	K6EB-48V		48	33.6	5.04	52.8	1,700	1,355	35	18
	K6EB-60V		60	42.0	6.3	66.0	2,800	1,286	44	23
	K6EB-110V		110	77.0	11.55	121.0	10,000	1,210	164	84

* Less than 1,000 Ω: ±10% More than 1,000 Ω: ±15%

REFERENCE DATA

1. Life curve

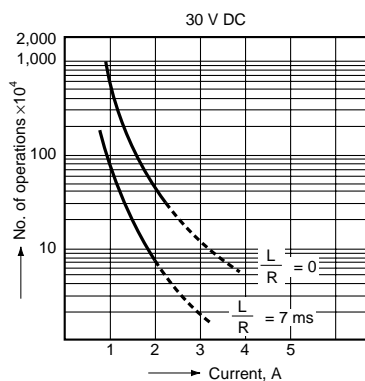

2. Coil temperature rise (resistance method)

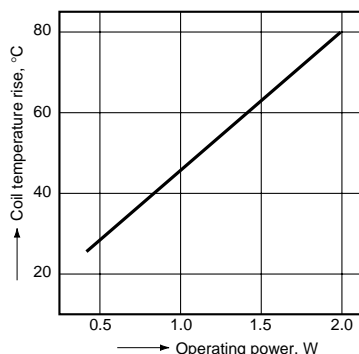

3. H₂S gas test (1,000 ppm)

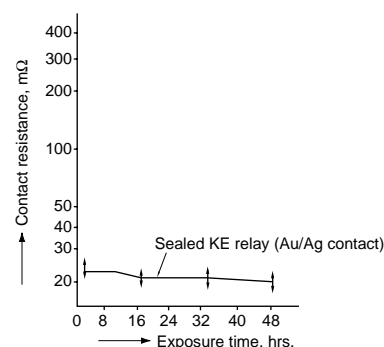

DIMENSIONS

2 Form C

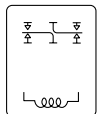
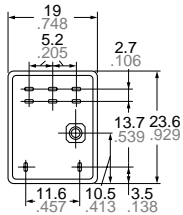
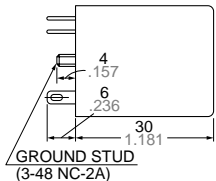
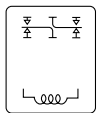
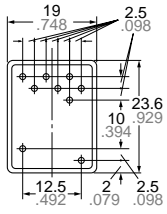
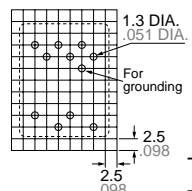
<p>Plug-in terminal (K2EB)</p>  <p>(N.O.) (N.C.)</p>		 <p>GROUND STUD (3-48 NC-2A)</p>
<p>PC board terminal (K2EBP)</p>  <p>(N.O.) (N.C.)</p>		<p>PC board pattern (Copper-side view)</p>  <p>1.3 DIA. .051 DIA. For grounding 2.5 .098 2.5 .098</p> <p>Tolerance: $\pm 0.3 \pm 0.12$</p>

4 Form C

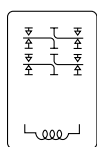
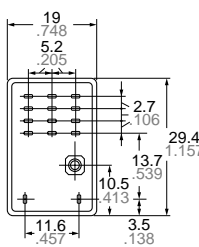
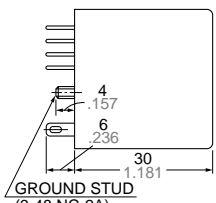
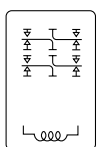
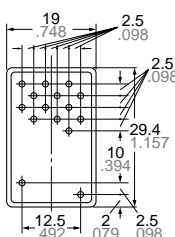
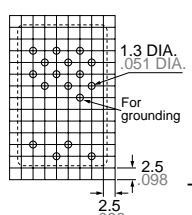
<p>Plug-in terminal (K4EB)</p>  <p>(N.O.) (N.C.) (N.O.) (N.C.)</p>		 <p>GROUND STUD (3-48 NC-2A)</p>
<p>PC board terminal (K4EBP)</p>  <p>(N.O.) (N.C.) (N.O.) (N.C.)</p>		<p>PC board pattern (Copper-side view)</p>  <p>1.3 DIA. .051 DIA. For grounding 2.5 .098 2.5 .098</p> <p>Tolerance: $\pm 0.3 \pm 0.12$</p>

6 Form C

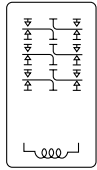
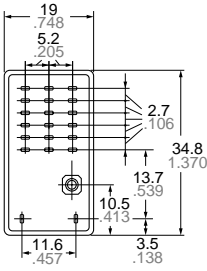
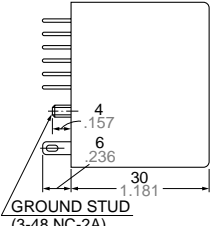





<p>Plug-in terminal (K6EB)</p>  <p>(N.O.) (N.C.) (N.O.) (N.C.) (N.O.) (N.C.)</p>		 <p>GROUND STUD (3-48 NC-2A)</p> <p>General tolerance: $\pm 0.5 \pm 0.20$</p>
---	---	--

K

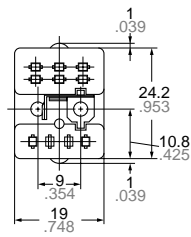
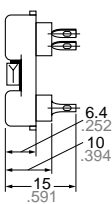
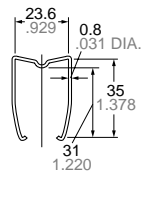
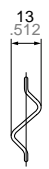
ACCESSORIES

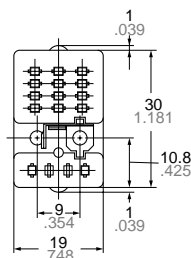
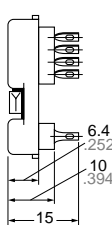
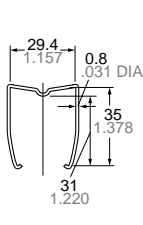
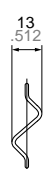

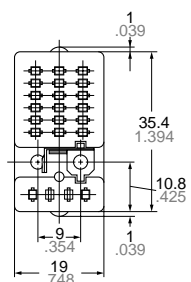
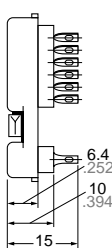
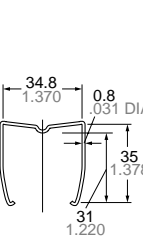

mm inch

Solder terminal sockets (with hold-down clip)

<p>K2-SS 2 Form C (for K2EB)</p>					
<p>K4-SS 4 Form C (for K4EB)</p>					
<p>K6-SS 6 Form C (for K6EB)</p>					

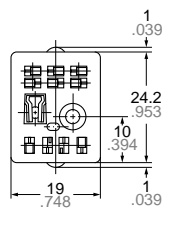
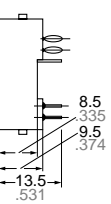
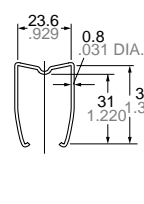
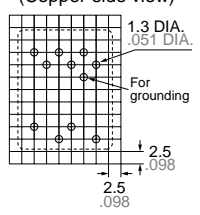
PC board terminal sockets (with hold-down clip)

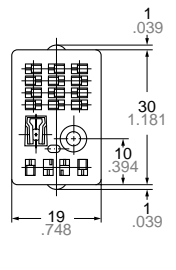
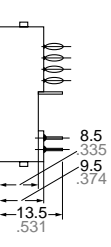
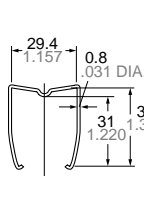
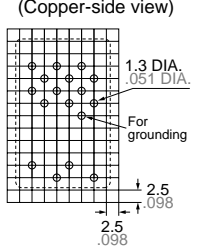
mm inch

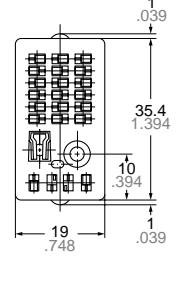
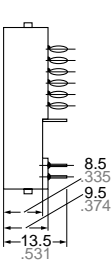
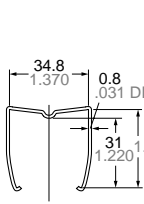
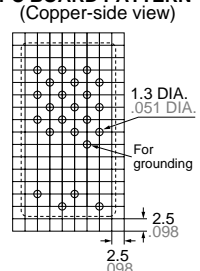
<p>K2-PS 2 Form C (for K2EB)</p>					<p>PC BOARD PATTERN (Copper-side view)</p> 
<p>K4-PS 4 Form C (for K4EB)</p>					<p>PC BOARD PATTERN (Copper-side view)</p> 
<p>K6-PS 6 Form C (for K6EB)</p>					<p>PC BOARD PATTERN (Copper-side view)</p> 

General tolerance: $\pm 1 \pm .039$

MOUNTING DIMENSIONS

Plug-in socket mounting

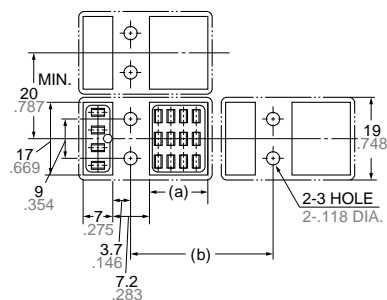
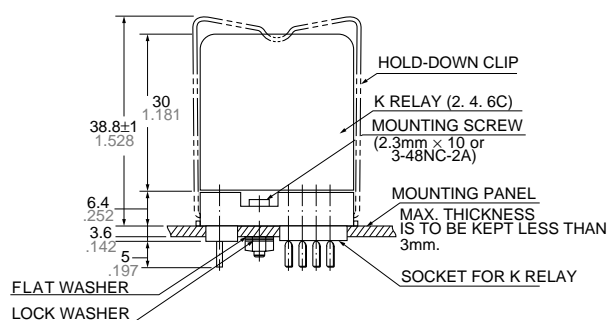

(a)	
K2:	8.5 .335
K4:	14 .551
K6:	19.5 .768
(b)	
K2:	26 1.024 MIN.
K4:	31.8 1.252 MIN.
K6:	37.2 1.465 MIN.

General tolerance: $\pm 0.5 \pm .020$

Tolerance: $\pm 0.1 \pm .004$

For Cautions for Use, see Relay Technical Information (Page 48 to 76).