

NT128S64VH4A0GM
128MB : 16M x 64
SDRAM SODIMM



16Mx64 bit One Bank Small Outline SDRAM Module

based on 16Mx16, 4Banks, 8K Refresh, 3.3V Synchronous DRAMs with SPD

Features

- 144 Pin JEDEC Standard, 8 Byte Small Outline Dual-In-line Memory Module
- 16Mx64 Synchronous DRAM SO DIMM
- Inputs and outputs are LVTTTL (3.3V) compatible
- 10 Ohm Resistors on DQs
- Single 3.3V ± 0.3V Power Supply
- Single Pulsed $\overline{\text{RAS}}$ interface
- SDRAMs have four internal banks
- Fully Synchronous to positive Clock Edge
- Data Mask for Byte Read/Write control
- Auto Refresh (CBR) and Self Refresh
- Automatic and controlled Precharge Commands
- Programmable Operation:
 - CAS Latency: 2, 3
 - Burst Type: Sequential or Interleave
 - Burst Length: 1, 2, 4, 8,
 - Operation: Burst Read and Write or Multiple Burst Read with Single Write
- Suspend Mode and Power Down Mode
- 13/9/2 Addressing (Row/Column/Bank)
- 8192 refresh cycles distributed across 64ms
- Serial Presence Detect
- Gold contacts

Description

NT128S64VH4A0GM is a 144-pin Synchronous DRAM Small Outline Dual In-line Memory Module (SO DIMM) that is organized as a 16Mx64 high-speed memory array. The SO DIMM uses four 16Mx16 SDRAMs in 400mil TSOP II packages and achieves high-speed data transfer rates of up to 133 MHz by employing a prefetch / pipeline hybrid architecture that supports the JEDEC 1N rule while allowing very low burst power.

All control, address, and data input/output circuits are synchronized with the positive edge of the externally supplied clock inputs. All inputs are sampled at the positive edge of the externally supplied clock (CK0). Internal operating modes are defined by combinations of the $\overline{\text{RAS}}$, $\overline{\text{CAS}}$, $\overline{\text{WE}}$, $\overline{\text{S0}}$, DQMB, and CKE0 signals. A command decoder initiates the necessary timings for each operation. A 15 bit address bus accepts address information in a row/column multiplexing arrangement.

Prior to any access operation, the $\overline{\text{CAS}}$ latency, burst type, burst length, and burst operation type must be programmed into the SO DIMM by address inputs A0-A9 during the mode register set cycle. The SO DIMM uses serial presence detects implemented via a serial EEPROM using the two pin IIC protocol. The first 128 bytes of serial PD data are used by the DIMM manufacturer. The last 128 bytes are available to the customer.

All Nanya 144-pin SO DIMMs provide a high performance, flexible 8-byte interface in a 2.66" long space-saving footprint.

Ordering Information

Part Number	Speed				Organization	Leads	Power
	MHz.	CL	t RCD	t RP			
NT128S64VH4A0GM-7K	143MHz	3	3	3	16Mx64	Gold	3.3V
	133MHz	2	2	2			
NT128S64VH4A0GM-75B	133MHz	3	3	3			
	100MHz	2	2	2			
NT128S64VH4A0GM-8B	125MHz	3	3	3			
	100MHz	2	2	2			

* CL = CAS Latency

Pin Description

CK0	Clock Inputs	DQ0-DQ63	Data input/output
CKE0	Clock Enable	DQMB0-DQMB7	Data Mask
$\overline{\text{RAS}}$	Row Address Strobe	VDD	Power (3.3V)
$\overline{\text{CAS}}$	Column Address Strobe	VSS	Ground
$\overline{\text{WE}}$	Write Enable	NC	No Connect
$\overline{\text{S0}}$	Chip Selects	SCL	Serial Presence Detect Clock Input
A0-A9, A11, A12	Address Inputs	SDA	Serial Presence Detect Data input/output
A10 / AP	Address Input/Autoprecharge	DU	Don't use
BA0, BA1	SDRAM Bank Address		

Pinout

Pin	Front	Pin	Back	Pin	Front	Pin	Back	Pin	Front	Pin	Back
1	VSS	2	VSS	51	DQ14	52	DQ46	95	DQ21	96	DQ53
3	DQ0	4	DQ32	53	DQ15	54	DQ47	97	DQ22	98	DQ54
5	DQ1	6	DQ33	55	VSS	56	VSS	99	DQ23	100	DQ55
7	DQ2	8	DQ34	57	NC	58	NC	101	VDD	102	VDD
9	DQ3	10	DQ35	59	NC	60	NC	103	A6	104	A7
11	VDD	12	VDD	Voltage Key				105	A8	106	BA0
13	DQ4	14	DQ36					107	VSS	108	VSS
15	DQ5	16	DQ37					109	A9	110	BA1
17	DQ6	18	DQ38	61	CK0	62	CKE0	111	A10/ AP	112	A11
19	DQ7	20	DQ39	63	VDD	64	VDD	113	VDD	114	VDD
21	VSS	22	VSS	65	$\overline{\text{RAS}}$	66	$\overline{\text{CAS}}$	115	DQMB2	116	DQMB6
23	DQMB0	24	DQMB4	67	$\overline{\text{WE}}$	68	NC	117	DQMB3	118	DQMB7
25	DQMB1	26	DQMB5	69	$\overline{\text{S0}}$	70	A12	119	VSS	120	VSS
27	VDD	28	VDD	71	NC	72	NC	121	DQ24	122	DQ56
29	A0	30	A3	73	DU	74	NC	123	DQ25	124	DQ57
31	A1	32	A4	75	VSS	76	VSS	125	DQ26	126	DQ58
33	A2	34	A5	77	NC	78	NC	127	DQ27	128	DQ59
35	VSS	36	VSS	79	NC	80	NC	129	VDD	130	VDD
37	DQ8	38	DQ40	81	VDD	82	VDD	131	DQ28	132	DQ60
39	DQ9	40	DQ41	83	DQ16	84	DQ48	133	DQ29	134	DQ61
41	DQ10	42	DQ42	85	DQ17	86	DQ49	135	DQ30	136	DQ62
43	DQ11	44	DQ43	87	DQ18	88	DQ50	137	DQ31	138	DQ63
45	VDD	46	VDD	89	DQ19	90	DQ51	139	VSS	140	VSS
47	DQ12	48	DQ44	91	VSS	92	VSS	141	SDA	142	SCL
49	DQ13	50	DQ45	93	DQ20	94	DQ52	143	VDD	144	VDD

Note: All pin assignments are consistent for all 8-byte versions.

SDRAM DIMM Block Diagram (1 Bank, 16Mx16 SDRAMs)

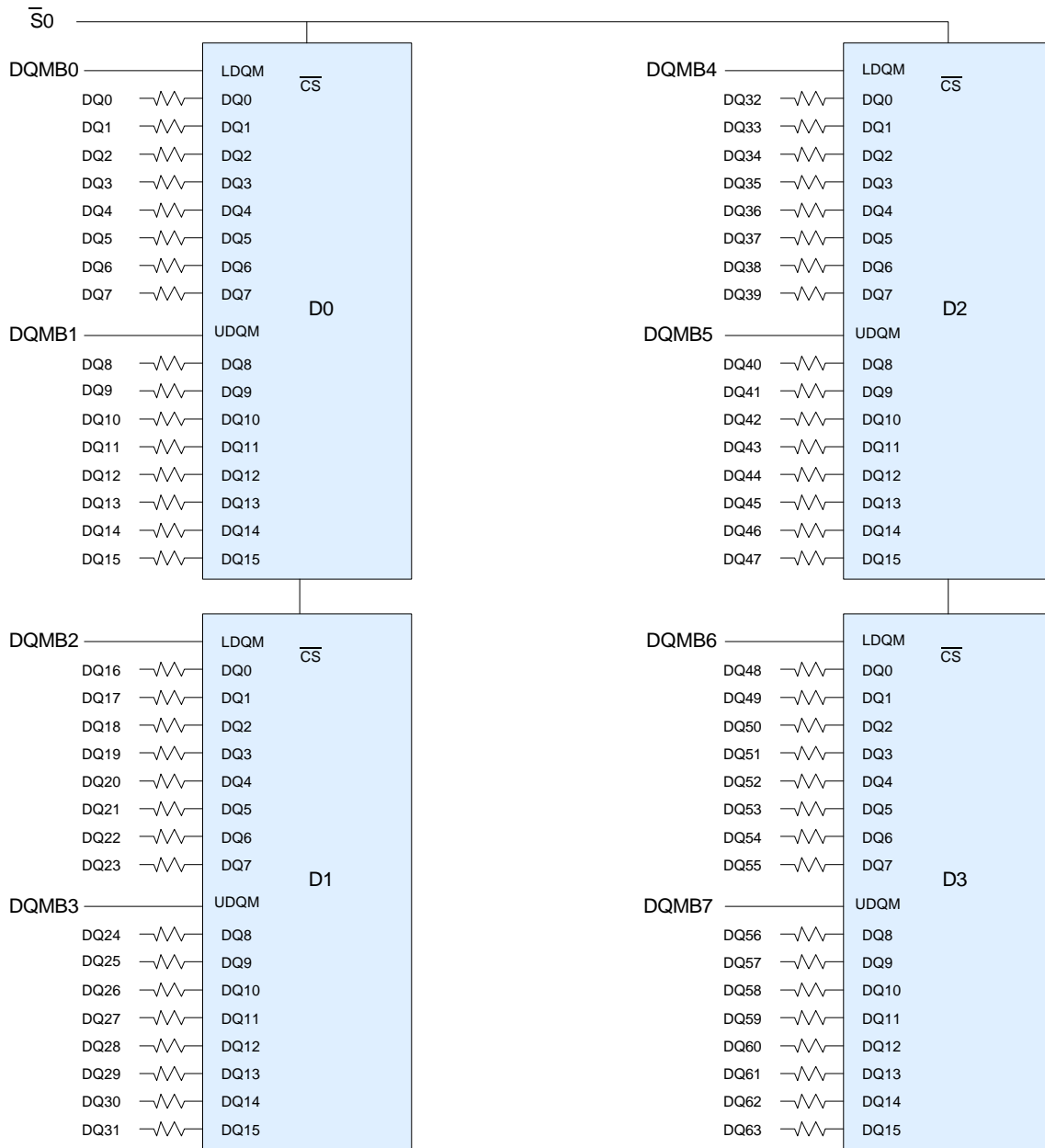

- \overline{RAS} → SDRAMs D0-D3
- \overline{CAS} → SDRAMs D0-D3
- CKE0 → SDRAMs D0-D3
- \overline{WE} → SDRAMs D0-D3
- A0-A12 → SDRAMs D0-D3
- BA0 → SDRAMs D0-D3
- BA1 → SDRAMs D0-D3
- DQn → Every DQ pin of SDRAM

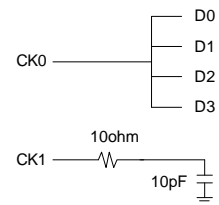
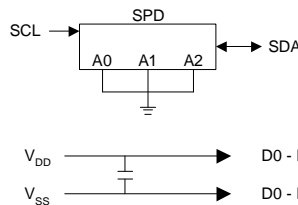

Input/Output Functional Description

Symbol	Type	Signal	Polarity	Function
CK0	Input	Pulse	Positive Edge	The system clock inputs. All of the SDRAM inputs are sampled on the rising edge of their associated clock.
CKE0	Input	Level	Active High	Activates the SDRAM CK0 signals when high and deactivates them when low. By deactivating the clocks, CKE0 low initiates the Power Down mode, Suspend mode, or the Self-Refresh mode.
$\overline{S0}$	Input	Pulse	Active Low	Enables the associated SDRAM command decoder when low and disables the command decoder when high. When the command decoder is disabled, new commands are ignored but previous operations continue.
\overline{RAS} , \overline{CAS} , \overline{WE}	Input	Pulse	Active Low	When sampled at the positive rising edge of the clock, \overline{RAS} , \overline{CAS} , \overline{WE} define the operation to be executed by the SDRAM.
BA0, BA1	Input	Level	-	Selects which SDRAM bank is to be active.
A0 - A9 A10/AP A11, A12	Input	Level	-	During a Bank Activate command cycle, A0-A12 defines the row address (RA0-RA12) when sampled at the rising clock edge. During a Read or Write command cycle, A0-A8 defines the column address (CA0-CA8) when sampled at the rising clock edge. In addition to the column address, AP is used to invoke Autoprecharge operation at the end of the Burst Read or Write cycle. If AP is high, autoprecharge is selected and BA0/BA1 define the bank to be precharged. If AP is low, autoprecharge is disabled. During a Precharge command cycle, AP is used in conjunction with BA0/BA1 to control which bank(s) to precharge. If AP is high all 4 banks will be precharged regardless of the state of BA0/BA1. If AP is low, then BA0/BA1 are used to define which bank to pre-charge.
DQ0 - DQ63	Input /Output	Level	-	Data and Check Bit input/output pins operate in the same manner as on conventional DRAMs.
DQMB0 -DQMB7	Input	Pulse	Active High	The Data input/output mask places the DQ buffers in a high impedance state when sampled high. In Read mode, DQM has a latency of two clock cycles and controls the output buffers like an output enable. In Write mode, DQM has a latency of zero and operates as a byte mask by allowing input data to be written if it is low but blocks the Write operation if DQM is high.
SDA	Input /Output	Level	-	Serial Data. Bi-directional signal used to transfer data into and out of the Serial Presence Detect EEPROM. Since the SDA signal is Open Drain/Open Collector at the EEPROM, a pull-up resistor is required on the system board.
SCL	Input	Pulse	-	Serial Clock. Used to clock all Serial Presence Detect data into and out of the EEPROM. Since the SCL signal is inactive in the "high" state, a pull-up resistor is recommended on the system board.
VDD, VSS	Supply			Power and ground for the module.

Absolute Maximum Ratings

Symbol	Parameter	Rating	Units	Notes
V _{DD}	Power Supply Voltage	-0.3 to +4.6	V	1
V _{IN}	Input Voltage	-0.3 to V _{DD} +0.3		
V _{OUT}	Output Voltage	-0.3 to V _{DD} +0.3		
T _A	Operating Temperature (ambient)	0 to +70	°C	1
T _{STG}	Storage Temperature	-55 to +125	°C	1
P _D	Power Dissipation	2.52	W	1
I _{OUT}	Short Circuit Output Current	50	mA	1

1. Stresses greater than those listed under "Absolute Maximum Ratings" may cause permanent damage to the device.
 This is a stress rating only and functional operation of the device at these or any other conditions above those indicated in the operational sections of this specification is not implied. Exposure to absolute maximum rating conditions for extended periods may affect reliability.

Recommended DC Operating Conditions (T_A=0 to 70 °C)

Symbol	Parameter	Rating			Units	Notes
		Min.	Typ.	Max.		
V _{DD}	Power Voltage	3.0	3.3	3.6	V	1
V _{IH}	Input High Voltage	2.0	-	V _{DD} + 0.3	V	1,2
V _{IL}	Input Low Voltage	-0.3	-	0.8	V	1,3
V _{OH}	Output High Voltage	2.4	-	-	V	
V _{OL}	Output Low Voltage	-	-	0.4	V	
I _{IL}	Input Leakage current	-10	-	10	uA	

1. All voltages referenced to V_{SS} .
2. V_{IH} (max) = V_{DD} / V_{DDQ} + 1.2V for pulse width ≤ 5ns
3. V_{IL} (min) = V_{SS} / V_{SSQ} - 1.2V for pulse width ≤ 5ns .

Capacitance (T_A=25 °C , f =1MHz, V_{DD}=3.3 ± 0.3V)

Symbol	Parameter	Max.	Unit
C _{I1}	Input Capacitance (A0-A9, A10/AP, A11, A12, BA0, BA1, \overline{RAS} , \overline{CAS} , \overline{WE})	24	pF
C _{I2}	Input Capacitance (CKE0)	21	
C _{I3}	Input Capacitance ($\overline{S0}$)	20	
C _{I4}	Input Capacitance (CK0)	13	
C _{I5}	Input Capacitance (DQMB0 - DQMB7)	10	
C _{I6}	Input Capacitance (SCL)	12	
C _{IO1}	Input/Output Capacitance (DQ0 - DQ63)	11	
C _{IO2}	Input/Output Capacitance (SDA)	15	

DC Output Load Circuit

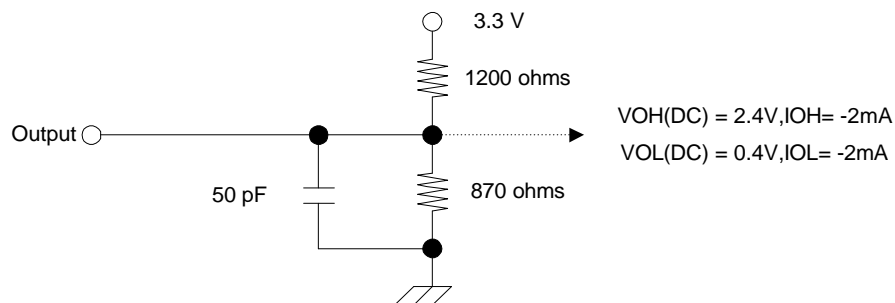

Operating, Standby, and Refresh Currents ($T_A = 0$ to 70 °C , $V_{DD} = 3.3 \pm 0.3V$)

Parameter	Symbol	Test condition	Speed			Unit	Note
			- 7K	- 75B	- 8B		
Operating current	I_{CC1}	1 bank operation , $t_{RC} = t_{RC}(min)$, $t_{CK} = min$ Active-Precharge Command cycling without burst operation	520	480	460	mA	1, 2
Precharge standby current in power-down mode	I_{CC2P}	$CKE0 \leq V_{IL}(max)$, $t_{CK} = min$, $\overline{S0} = V_{IH}(min)$	8			mA	
	I_{CC2PS}	$CKE0 \leq V_{IL}(max)$, $t_{CK} = \infty$, $\overline{S0} = V_{IH}(min)$	8			mA	
Precharge standby current in non power-down mode	I_{CC2N}	$CKE0 \geq V_{IH}(min)$, $t_{CK} = min$ $\overline{S0} = V_{IH}(min)$	120	120	80	mA	3
	I_{CC2NS}	$CKE0 \geq V_{IH}(min)$, $t_{CK} = \infty$ $\overline{S0} = V_{IH}(min)$	32	32	32	mA	4
No Operating current (Active state : 4 bank)	I_{CC3P}	$CKE0 \leq V_{IL}(max)$, $t_{CK} = min$. $\overline{S0} = V_{IH}(min)$, (Power Down Mode)	24	24	24	mA	5
	I_{CC3N}	$CKE0 \geq V_{IH}(min)$, $t_{CK} = min$ $\overline{S0} = V_{IH}(min)$	240	240	240	mA	3
Operating current (Burst mode)	I_{CC4}	$t_{CK} = min$, Read/ Write command cycling, Multiple banks active, gapless data, BL=4	480	480	360	mA	2, 6
Auto(CBR) refresh current	I_{CC5}	$t_{CK} = min$, CBR command cycling	760	760	680	mA	
Self refresh current	I_{CC6}	$CKE0 \leq 0.2V$	12			mA	
Serial PD Device Standby Current	I_{SB}	$V_{IN} = GND$ or V_{DD}	30			μA	7

1. These parameters depend on the cycle rate and are measured with the cycle determined by the minimum value of t_{CK} and t_{RC} . Input signals are changed up to three times during t_{RC} (min).
2. The specified values are obtained with the output open.
3. Input signals are changed once during three clock cycles.
4. Input signals are stable.
5. Active standby current will be higher if Clock Suspend is entered during a Burst Read cycle (add 1mA per DQ).
6. Input signals are changed once during $t_{CK}(min)$.
7. $V_{DD} = 3.3V$

AC Characteristics ($T_A = 0$ to 70 °C , $V_{DD} = 3.3 \pm 0.3V$)

1. An initial pause of $200\mu s$, with DQMB0-7 and CKE0 held high, is required after power-up. A Precharge All Banks command must be given followed by a minimum of eight Auto (CBR) Refresh cycles before or after the Mode Register Set operation.
2. The Transition time is measured between V_{IH} and V_{IL} (or between V_{IH} and V_{IL}).
3. In addition to meeting the transition rate specification, the CLK and CKE signals must transit between V_{IH} and V_{IL} (or between V_{IL} and V_{IH}) in a monotonic manner.
4. AC timing tests have $V_{IL} = 0.8V$ and $V_{IH} = 2.0V$ with the timing referenced to the $1.40V$ cross over point.
5. AC measurements assume $t_T = 1.2$ ns.

AC Output Load Circuits

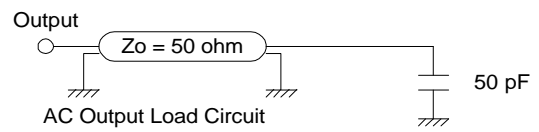
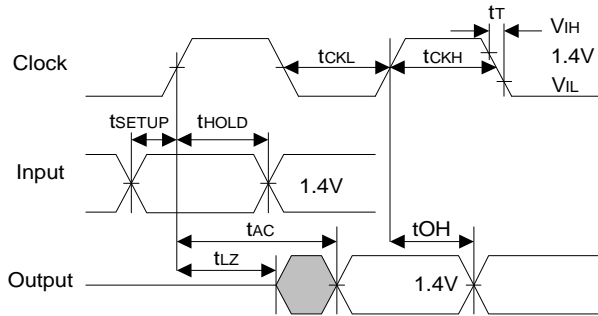

AC Timing Parameters

Clock and Clock Enable Parameters

Symbol	Parameter	- 7K		- 75B		- 8B		Unit	Note
		Min.	Max.	Min.	Max.	Min.	Max.		
tCK3	Clock Cycle Time, $\overline{\text{CAS}}$ Latency = 3	7	1000	7.5	1000	8	1000	ns	
tCK2	Clock Cycle Time, $\overline{\text{CAS}}$ Latency = 2	7.5	1000	10	1000	10	1000	ns	
tAC3(B)	Clock Access Time, $\overline{\text{CAS}}$ Latency = 3	-	5.4	-	5.4	-	6	ns	1
tAC2(B)	Clock Access Time, $\overline{\text{CAS}}$ Latency = 2	-	5.4	-	6	-	6	ns	1
tCKH	Clock High Pulse Width	2.5	-	2.5	-	3	-	ns	2
tCKL	Clock Low Pulse Width	2.5	-	2.5	-	3	-	ns	2
tCES	Clock Enable Set-up Time	1.5	-	1.5	-	2	-	ns	
tCEH	Clock Enable Hold Time	0.8	-	0.8	-	1	-	ns	
tSB	Power down mode Entry Time	0	7.5	0	7.5	0	12	ns	
tT	Transition Time (Rise and Fall)	0.5	10	0.5	10	0.5	10	ns	

1. Access time is measured at 1.4V. In AC Characteristics section, see notes.
2. tCKH is the pulse width of CLK measured from the positive edge to the negative edge referenced to VIH (min). tCKL is the pulse width of CLK measured from the negative edge to the positive edge referenced to VIL (max).

Common Parameters

Symbol	Parameter	- 7K		- 75B		- 8B		Unit	Note
		Min.	Max.	Min.	Max.	Min.	Max.		
tCS	Command Setup Time	1.5	-	1.5	-	2	-	ns	
tCH	Command Hold Time	0.8	-	0.8	-	1	-	ns	
tAS	Address and Bank Select Set-up Time	1.5	-	1.5	-	2	-	ns	
tAH	Address and Bank Select Hold Time	0.8	-	0.8	-	1	-	ns	
tRCD	$\overline{\text{RAS}}$ to $\overline{\text{CAS}}$ Delay	20	-	20	-	20	-	ns	1
tRC	Bank Cycle Time	60	-	67.5	-	70	-	ns	1
tRFC	Auto Refresh to Active/Auto Refresh	60	-	67.5	-	70	-		
tRAS	Active Command Period	45	100K	45	100K	50	100K	ns	1
tRP	Precharge Time	20	-	20	-	20	-	ns	1
tRRD	Bank to Bank Delay Time	15	-	15	-	20	-	ns	1
tCCD	$\overline{\text{CAS}}$ to $\overline{\text{CAS}}$ Delay Time	1	-	1	-	1	-	CLK	

1. These parameters account for the number of clock cycle and depend on the operating frequency of the clock, as follows:
the number of clock cycles = specified value of timing / clock period (count fractions as a whole number).

Mode Register Set Cycle

Symbol	Parameter	- 7K		- 75B		- 8B		Unit	Note
		Min.	Max.	Min.	Max.	Min.	Max.		
tRSC	Mode Register Set Cycle Time	2	-	2	-	2	-	CLK	1

1. These parameters account for the number of clock cycle and depend on the operating frequency of the clock, as follows:
the number of clock cycles = specified value of timing / clock period (count fractions as a whole number).

Read Cycle

Symbol	Parameter	- 7K		- 75B		- 8B		Unit	Note
		Min.	Max.	Min.	Max.	Min.	Max.		
tOH	Data Out Hold Time	-	-	-	-	2.5	-	ns	
		2.7	-	2.7	-	3	-	ns	
tLZ	Data Out to Low Impedance Time	0	-	0	-	0	-	ns	
tHZ3	Data Out to High Impedance Time	3	5.4	3	5.4	3	6	ns	1
tDQZ	DQM Data Out Disable Latency	2	-	2	-	2	-	CLK	

1. Referenced to the time at which the output achieves the open circuit condition, not to output voltage levels.

Refresh Cycle

Symbol	Parameter	- 7K		- 75B		- 8B		Unit	Note
		Min.	Max.	Min.	Max.	Min.	Max.		
tREF	Refresh Period	-	64	-	64	-	64	ms	
tSREX	Self Refresh Exit Time	10	-	10	-	10	-	ns	

Write Cycle

Symbol	Parameter	- 7K		- 75B		- 8B		Unit	Note
		Min.	Max.	Min.	Max.	Min.	Max.		
tDS	Data In Set-up Time	1.5	-	1.5	-	2	-	ns	
tDH	Data In Hold Time	0.8	-	0.8	-	1	-	ns	
tDPL	Data input to Precharge	15	-	15	-	15	-	ns	
tDAL3	Data In to Active Delay CAS Latency = 3	5	-	5	-	5	-	CLK	
tDAL2	Data In to Active Delay CAS Latency = 2	5	-	-	-	-	-	CLK	
tDQW	DQM Write Mask Latency	0	-	0	-	0	-	ns	

Serial Presence Detect -- Part 1 of 2

16Mx64 SDRAM SODIMM based on 16Mx16, 4Banks, 8K Refresh, 3.3V SDRAMs with SPD

Byte	Description	SPD Entry Value			Serial PD Data Entry (Hexadecimal)			Note
		-7K	-75B	-8B	-7K	-75	-8B	
0	Number of Serial PD Bytes Written during Production	128			80			
1	Total Number of Bytes in Serial PD device	256			08			
2	Fundamental Memory Type	SDRAM			04			
3	Number of Row Addresses on Assembly	13			0D			
4	Number of Column Addresses on Assembly	9			09			
5	Number of DIMM Bank	1			01			
6	Data Width of Assembly	X64			40			
7	Data Width of Assembly (cont')	X64			00			
8	Voltage Interface Level of this Assembly	LVTTTL			01			
9	SDRAM Device Cycle Time at CL=3	7ns	7.5ns	8ns	70	75	80	
10	SDRAM Device Access Time from Clock at CL=3	5.4ns	5.4ns	6ns	54	54	60	
11	DIMM Configuration Type	Non-Parity			00			
12	Refresh Rate/Type	7.8µs / SR			82			
13	Primary SDRAM Width	X16			10			
14	Error Checking SDRAM Device Width	N/A			00			
15	SDRAM Device Attributes : Minimum Clock Delay, Random Column Access	1 Clock			01			
16	SDRAM Device Attributes: Burst Length Supported	1,2,4,8			0F			
17	SDRAM Device Attributes: Number of Device Banks	4			04			
18	SDRAM Device Attributes: CAS Latency	2, 3	2, 3	2, 3	06	06	06	
19	SDRAM Device Attributes: \overline{CS} Latency	0			01			
20	SDRAM Device Attributes: \overline{WE} Latency	0			01			
21	SDRAM Module Attributes	Unbuffered			00			
22	SDRAM Device Attributes: General	Wr-1/Rd Burst, Precharge All, Auto-Precharge, VDD +/- 10%			0E			
23	Minimum Clock Cycle at CL=2	7.5ns	10ns	10ns	75	A0	A0	
24	Maximum Data Access Time from Clock at CL=2	5.4ns	6ns	6ns	54	60	60	
25	Minimum Clock Cycle Time at CL=1	N/A			00			
26	Maximum Data Access Time from Clock at CL=1	N/A			00			
27	Minimum Row Precharge Time (tRP)	15ns	20ns	20ns	0F	14	14	
28	Minimum Row Active to Row Active delay (tRRD)	15ns	15ns	20ns	0F	0F	14	
29	Minimum RAS to CAS delay (tRCD)	15ns	20ns	20ns	0F	14	14	
30	Minimum RAS Pulse Width (tRAS)	45ns	45ns	50ns	2D	2D	32	
31	Module Bank Density	128MB			20			
32	Address and Command Setup Time Before Clock	1.5ns	1.5ns	2ns	15	15	20	
33	Address and Command Hold Time After Clock	0.8ns	0.8ns	1ns	08	08	10	
34	Data Input Setup Time Before Clock	1.5ns	1.5ns	2ns	15	15	20	
35	Data Input Hold Time After Clock	0.8ns	0.8ns	1ns	08	08	10	
36-61	Reserved	Undefined			00			
62	SPD Revision	1.2	1.2	1.2	12	12	12	
63	Checksum for bytes 0 - 62				F3	39	80	

NT128S64VH4A0GM
128MB : 16M x 64
SDRAM SODIMM



Serial Presence Detect -- Part 2 of 2

16Mx64 SDRAM SODIMM based on 16Mx16, 4Banks, 8K Refresh, 3.3V SDRAMs with SPD

Byte	Description	SPD Entry Value			Serial PD Data Entry (Hexadecimal)			Note
		-7K	-75B	-8B	-7K	-75B	-8B	
64-71	Manufacturer's JEDED ID Code	NANYA			7F7F7F0B00000000			3
72	Module Manufacturing Location	N/A			00			
73-90	Module Part number	N/A	N/A	N/A	00	00	00	
91-92	Module Revision Code	N/A			00			
93-94	Module Manufacturing Data	Year/Week Code			yy/ww			1,2
95-98	Module Serial Number	Serial Number			00			
99-125	Reserved	Undefined			00			
126	Modules Supports this Clock Frequency	100MHz			64			
127	Attributes for Clock Frequency defined in byte 126	CK0, CK1, CK2,CK3, CL3, CL2 Concurrent AP			FF			
128-255	Open for customer Use	Undefined			00			

1. yy= Binary coded decimal year code, 0-99(Decimal), 00-63(Hex)
2. ww= Binary coded decimal year code, 01-52(Decimal), 01-34(Hex)
3. NANYA 11decimal (bank four) 0000 1011 binary 0B Hex.

Package Dimensions

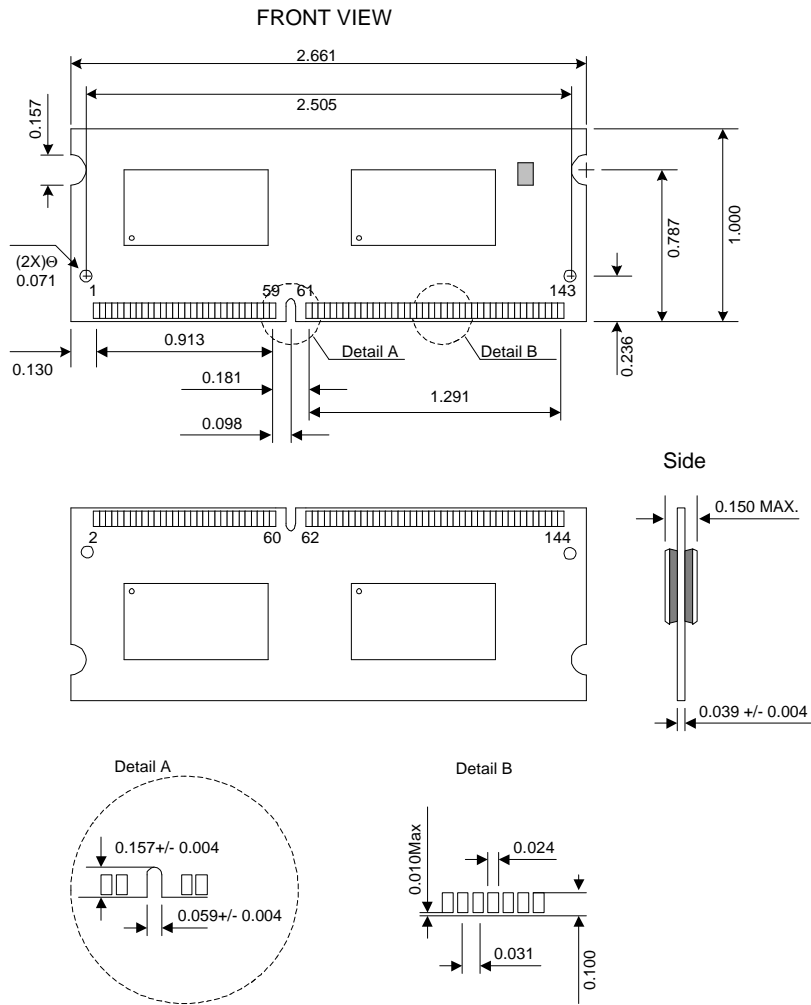

Note : All dimension are typical unless otherwise stated.

Unit : Inchs