

**1 310 nm InGaAsP STRAINED MQW DC-PBH LASER DIODE
COAXIAL MODULE WITH SINGLE MODE FIBER****DESCRIPTION**

NDL7408P Series is a 1 310 nm laser diode coaxial module with single mode fiber. It has a strained Multiple Quantum Well (st-MQW) structure and a built-in InGaAs monitor photo diode. It is recommended for junction or access network systems. The series is available in two types of output power: 1.0 mW and 0.2 mW.

FEATURES

- Center wavelength $\lambda_c = 1\ 310\ \text{nm}$
- Two types of output power : 1.0 mW (NDL7408PK Series)
0.2 mW (NDL7408PL Series)
- Low threshold current $I_{th} = 12\ \text{mA TYP. @}T_c = 25\ ^\circ\text{C}$
- High cut-off frequency $f_c = 2.0\ \text{GHz}$
- InGaAs monitor PIN-PD
- Wide operating temperature range: $-40\ \text{to}\ +85\ ^\circ\text{C}$
- Based on Bellcore TA-NWT-000983

The information in this document is subject to change without notice.

★ PACKAGE DIMENSIONS (in millimeters)

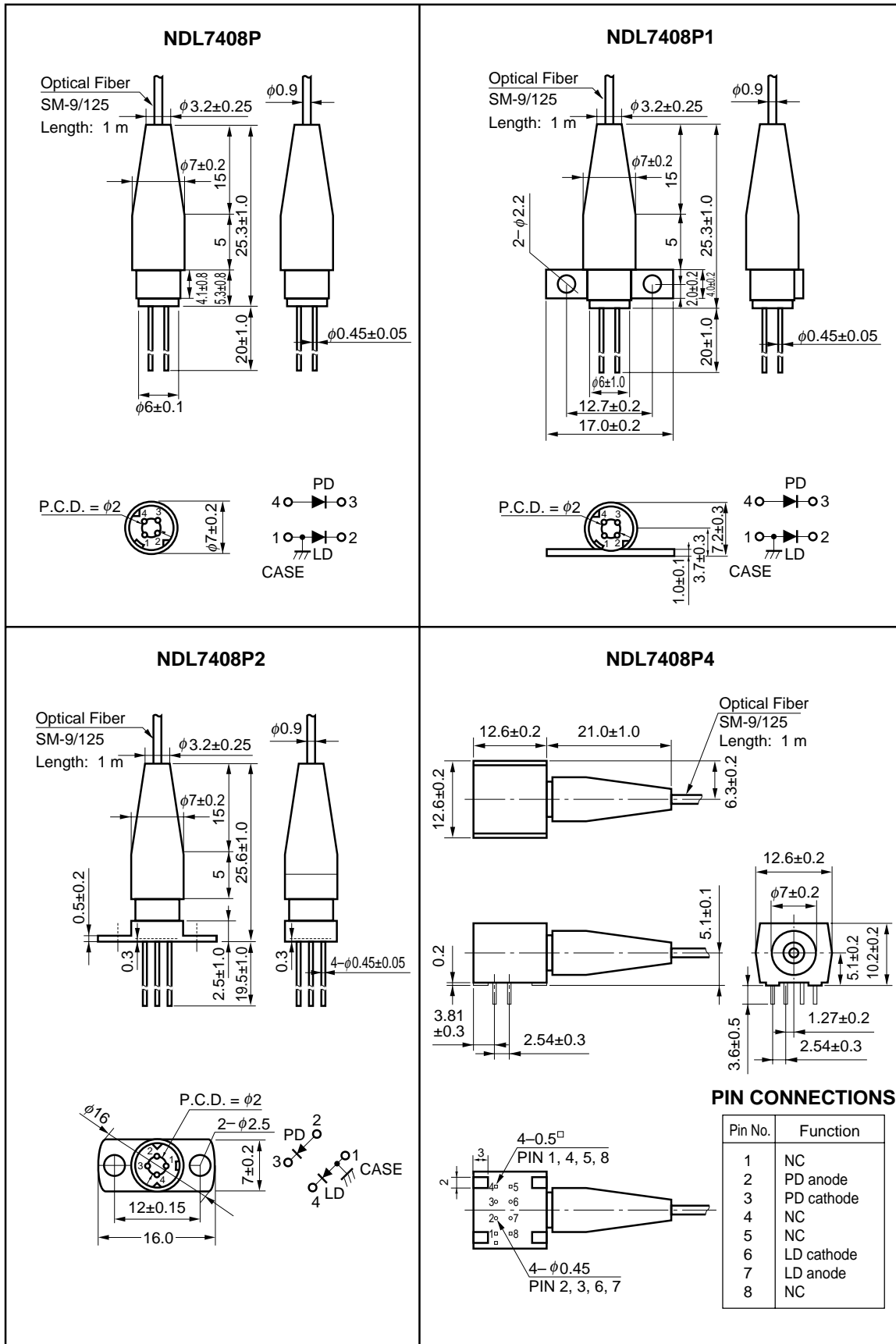

ORDERING INFORMATION

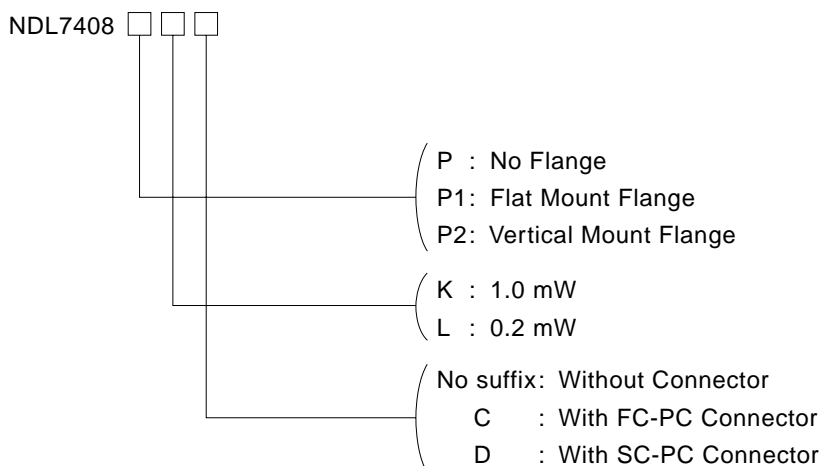

Part Number	Ranks	Description	
NDL7408PK	M	1.0 mW No Flange	Without Connector
NDL7408PKC			With FC-PC Connector
NDL7408PKD			With SC-PC Connector
NDL7408P1K	M	1.0 mW Flat Mount Flange	Without Connector
NDL7408P1KC			With FC-PC Connector
NDL7408P1KD			With SC-PC Connector
NDL7408P2K	M	1.0 mW Vertical Flange	Without Connector
NDL7408P2KC			With FC-PC Connector
NDL7408P2KD			With SC-PC Connector
NDL7408P4K	M	1.0 mW 8-pin DIP	Without Connector
NDL7408P4KC			With FC-PC Connector
NDL7408P4KD			With SC-PC Connector
NDL7408PL	N	0.2 mW No Flange	Without Connector
NDL7408PLC			With FC-PC Connector
NDL7408PLD			With SC-PC Connector
NDL7408P1L	N	0.2 mW Flat Mount Flange	Without Connector
NDL7408P1LC			With FC-PC Connector
NDL7408P1LD			With SC-PC Connector
NDL7408P2L	N	0.2 mW Vertical Flange	Without Connector
NDL7408P2LC			With FC-PC Connector
NDL7408P2LD			With SC-PC Connector
NDL7408P4L	N	0.2 mW 8-pin DIP	Without Connector
NDL7408P4LC			With FC-PC Connector
NDL7408P4LD			With SC-PC Connector

ABSOLUTE MAXIMUM RATINGS (T_c = 25 °C, unless otherwise specified)

Parameter	Symbol	Ratings	Unit
Forward Current of LD	I _F	I _{th} + 50	mA
Reverse Voltage of LD	V _R	2.0	V
Forward Current of PD	I _F	10	mA
Reverse Voltage of PD	V _R	20	V
Operating Case Temperature	T _c	-40 to +85	°C
Storage Temperature	T _{stg}	-40 to +85	°C
Lead Soldering Temperature (10 s)	T _{std}	260	°C

ELECTRO-OPTICAL CHARACTERISTICS (T_c = 25 °C, unless otherwise specified)

Parameter	Symbol	Conditions	MIN.	TYP.	MAX.	Unit
Operating Voltage	V _{op}	*1		1.1	1.3	V
Threshold Current	I _{th}			10	25	mA
		T _c = +85 °C		25	50	
Modulation Current	I _{mod}	P _f = 1.0 mW @NDL7408PK Series		15	30	mA
		P _f = 0.2 mW @NDL7408PL Series				
Differential Efficiency from Fiber for NDL7408PK Series	η _d		0.025	0.050		W/A
		T _c = +85 °C	0.018	0.035		
Differential Efficiency from Fiber for NDL7408PL Series	η _d		0.010	0.015		
		T _c = +85 °C	0.005	0.010		
Center Emission Wavelength	λ _c	*1, RMS (-20 dB)	1 290	1 310	1 330	nm
		T _c = -40 to +85 °C	1 260		1 360	
Temperature Dependence of Center Emission Wavelength	Δλ/ΔT	T _c = -40 to +85 °C		0.4	0.5	nm/°C
Spectral Width	σ	*1, RMS (-20 dB)		1.3	2.5	nm
		T _c = +85 °C		1.5	4	
Cut-off Frequency	f _c	-3 dB		2.0		GHz
Rise Time	t _r	10 to 90 %		0.2	0.5	ns
Fall Time	t _f	90 to 10 %		0.3	0.5	ns
Monitor Current of PD	I _m	V _{RD} = 5 V, *1	100	700		μA
Dark Current of PD	I _D	V _{RD} = 5 V		0.1	10	nA
Tracking Error	γ ²	I _m = const., T _c = -40 to +85 °C		0.5	1.0	dB

*1 P_f = 1.0 mW @NDL7408PK Series
 P_f = 0.2 mW @NDL7408PL Series

*2 $\gamma = \left| 10 \log \frac{P_f}{X \text{ mW}} \right|$

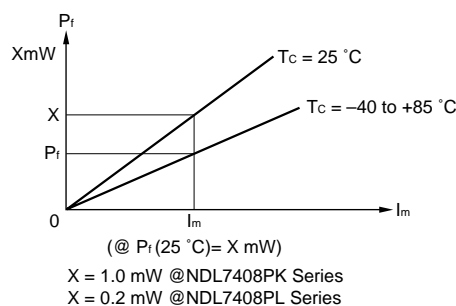

TYPICAL CHARACTERISTICS ($T_c = -40$ to $+85$ °C)

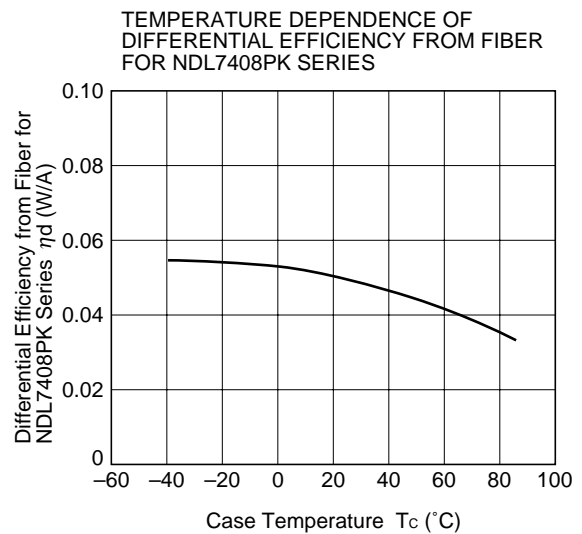
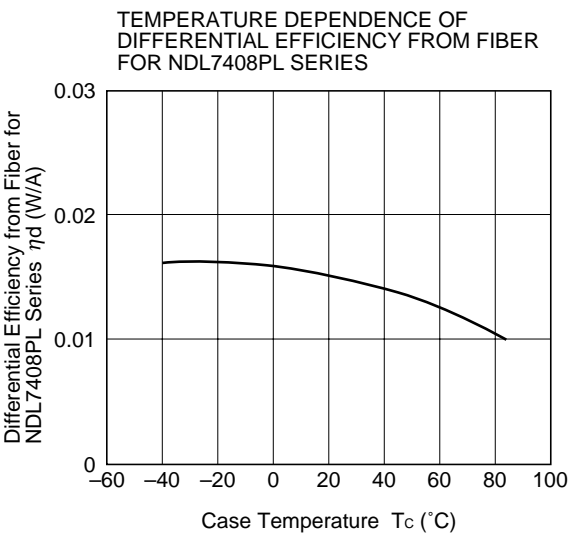
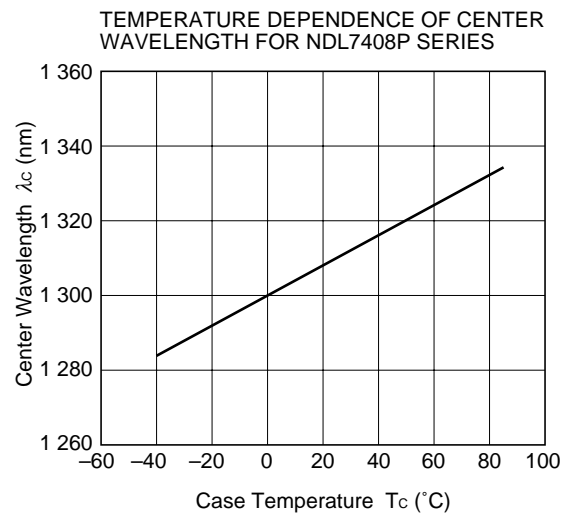
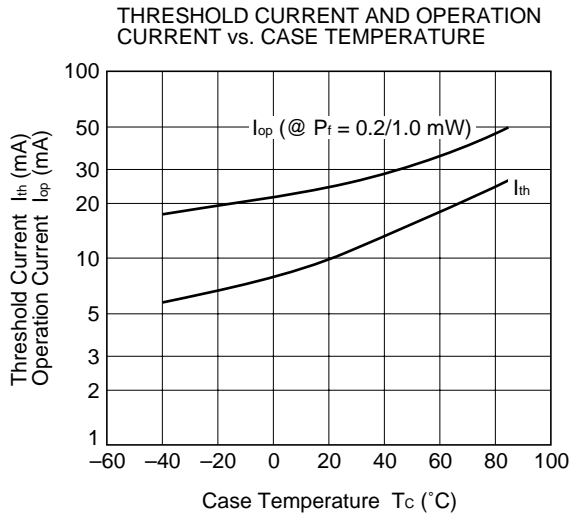
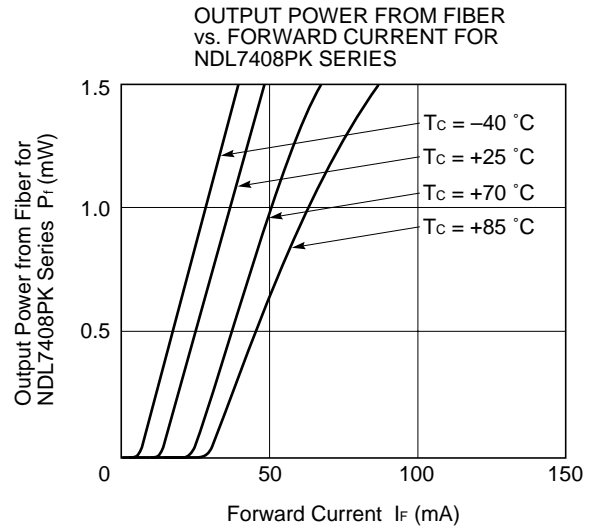
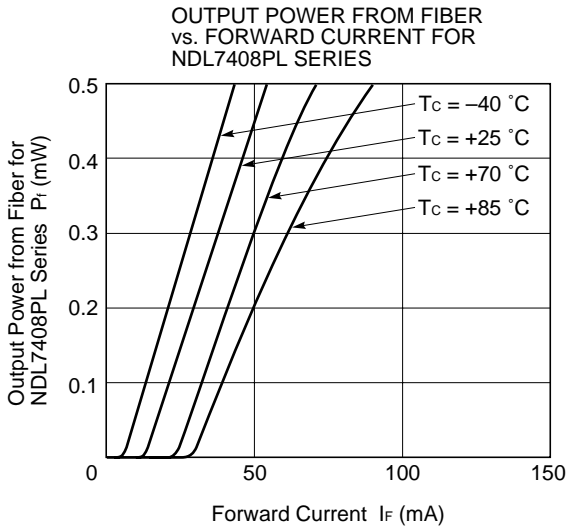

TYPICAL CHARACTERISTICS (T_c = 25 °C)

LONGITUDINAL MODE FROM FIBER FOR NDL7408P SERIES

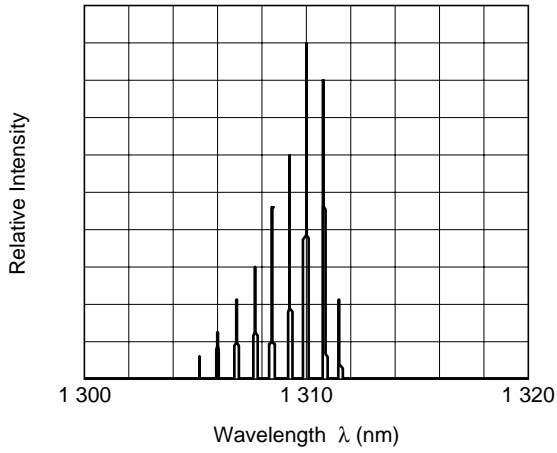

OUTPUT POWER FROM FIBER vs. LD MONITOR CURRENT

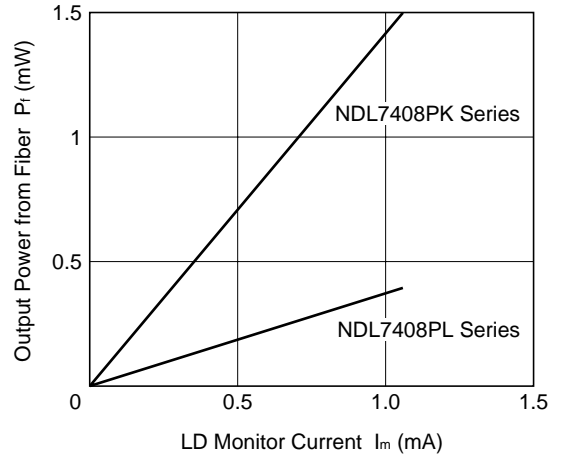

FORWARD CURRENT vs. FORWARD VOLTAGE FOR NDL7408P SERIES

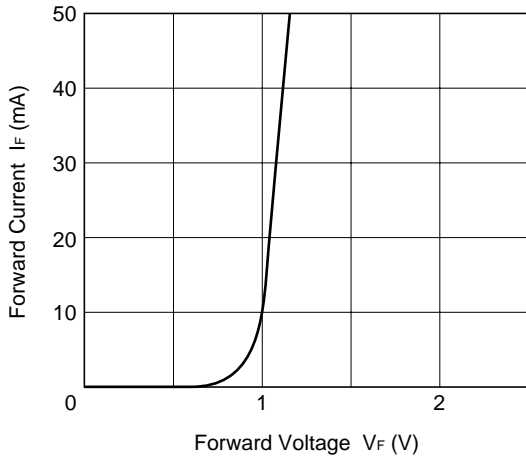

FREQUENCY RESPONSE (P_f = 0.2 / 1.0 (mW))

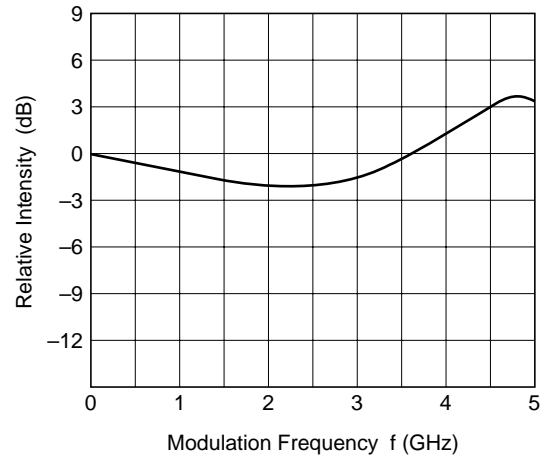

1.3 μm FABRY-PEROT DC-PBH LASER DIODE FAMILY

Package	Features	Part Number	Remarks
φ5.6 mm Small Can		NDL7001	With monitor photo diode
φ5.6 mm Small Can with Lens		NDL7001L	With monitor photo diode
4-pin Coaxial Module with SMF		NDL7401P Series NDL7408P Series	Without TEC With monitor photo diode

REFERENCE

Document Name	Document No.
NEC semiconductor device reliability/quality control system	LEI-1201
Quality grades on NEC semiconductor devices	IEI-1209
Semiconductor device mounting technology manual	C10535E
Guide to quality assurance for semiconductor devices	MEI-1202
Semiconductor selection guide	X10679E

CAUTION

Within this device there exists GaAs (Gallium Arsenide) material which is a harmful substance if ingested. Please do not under any circumstances break the hermetic seal.

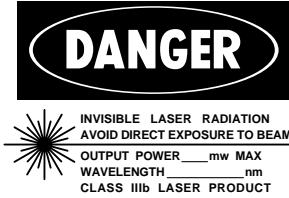

SEMICONDUCTOR LASER

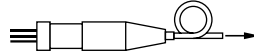

AVOID EXPOSURE-Invisible
Laser Radiation is emitted from this aperture

NEC Corporation
NEC Building, 7-1, Shiba 5-chome,
Minato-ku, Tokyo 108-01, Japan
Type number: _____
Manufactured: _____
Serial number: _____
This product conforms to FDA regulations as applicable to standards 21 CFR Chapter 1, Subchapter J.

The export of this product from Japan is prohibited without governmental license. To export or re-export this product from a country other than Japan may also be prohibited without a license from that country. Please call an NEC sales representative.

No part of this document may be copied or reproduced in any form or by any means without the prior written consent of NEC Corporation. NEC Corporation assumes no responsibility for any errors which may appear in this document.

NEC Corporation does not assume any liability for infringement of patents, copyrights or other intellectual property rights of third parties by or arising from use of a device described herein or any other liability arising from use of such device. No license, either express, implied or otherwise, is granted under any patents, copyrights or other intellectual property rights of NEC Corporation or others.

While NEC Corporation has been making continuous effort to enhance the reliability of its semiconductor devices, the possibility of defects cannot be eliminated entirely. To minimize risks of damage or injury to persons or property arising from a defect in an NEC semiconductor device, customer must incorporate sufficient safety measures in its design, such as redundancy, fire-containment, and anti-failure features.

NEC devices are classified into the following three quality grades:

"Standard", "Special", and "Specific". The Specific quality grade applies only to devices developed based on a customer designated "quality assurance program" for a specific application. The recommended applications of a device depend on its quality grade, as indicated below. Customers must check the quality grade of each device before using it in a particular application.

Standard: Computers, office equipment, communications equipment, test and measurement equipment, audio and visual equipment, home electronic appliances, machine tools, personal electronic equipment and industrial robots

Special: Transportation equipment (automobiles, trains, ships, etc.), traffic control systems, anti-disaster systems, anti-crime systems, safety equipment and medical equipment (not specifically designed for life support)

Specific: Aircrafts, aerospace equipment, submersible repeaters, nuclear reactor control systems, life support systems or medical equipment for life support, etc.

The quality grade of NEC devices in "Standard" unless otherwise specified in NEC's Data Sheets or Data Books. If customers intend to use NEC devices for applications other than those specified for Standard quality grade, they should contact NEC Sales Representative in advance.

Anti-radioactive design is not implemented in this product.