

**17 cm (6.5 type), 640 × 480 pixels 262144 colors,
high luminance, wide viewing angle**

DESCRIPTION

NL6448BC20-08 is a TFT (thin film transistor) active matrix color liquid crystal display (LCD) comprising amorphous silicon TFT attached to each signal electrode, a driving circuit and a backlight. NL6448BC20-08 has a built-in backlight. Backlight includes long-life lamps and the lamps are replaceable.

The 17 cm diagonal display area contains 640 × 480 pixels and can display 262144 colors simultaneously.

NL6448BC20-08 is suitable for industrial application use, because the luminance is high, and the viewing direction is selectable with display scan select.

FEATURES

- High luminance (300 cd/m², typ.)
- Low reflection
- Wide viewing angle with retardation film (Antiglare treatment)
- Display reverse scan function
- 6-bit digital RGB signals
- Edge type backlight with long-life-lamps (Two lamp holders, inverter-less)
- Variable luminance control
- Recommended inverter (Part No. 65PWB31)
- Compatible to the mounting holes position of NL6448AC20-06 except for inverter.

APPLICATIONS

- Measuring instruments
- Display terminals for control system
- Monitors for process controller

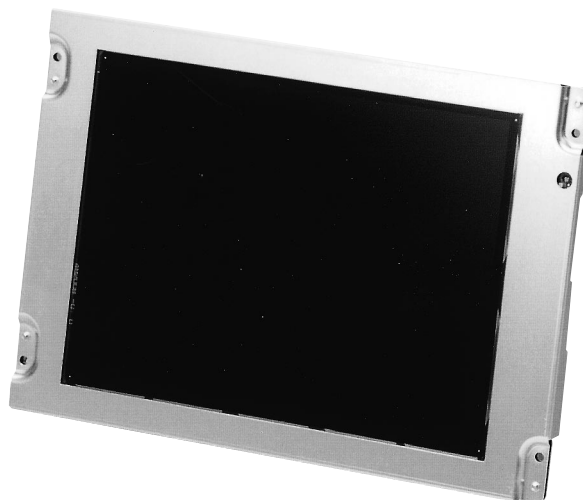

STRUCTURE AND FUNCTIONS

A color TFT (thin film transistor) LCD module is comprised of a TFT liquid crystal panel structure. LSIs for driving the TFT array, and a backlight assembly. The TFT panel structure is created by sandwiching liquid crystal material in the narrow gap between a TFT array glass substrate and a color filter glass substrate. After the driver LSIs are connected to the panel, the backlight assembly is attached to the backside of the panel.

RGB (red, green, blue) data signals from a source system is modulated into a form suitable for active matrix addressing by the onboard signal processor and sent to the driver LSIs which in turn addresses the individual TFT cells.

Acting as an electro-optical switch, each TFT cell regulates light transmission from the backlight assembly when activated by the data source. By regulating the amount of light passing through the array of red, green, and blue dots, color images are created with clarity.

BLOCK DIAGRAM

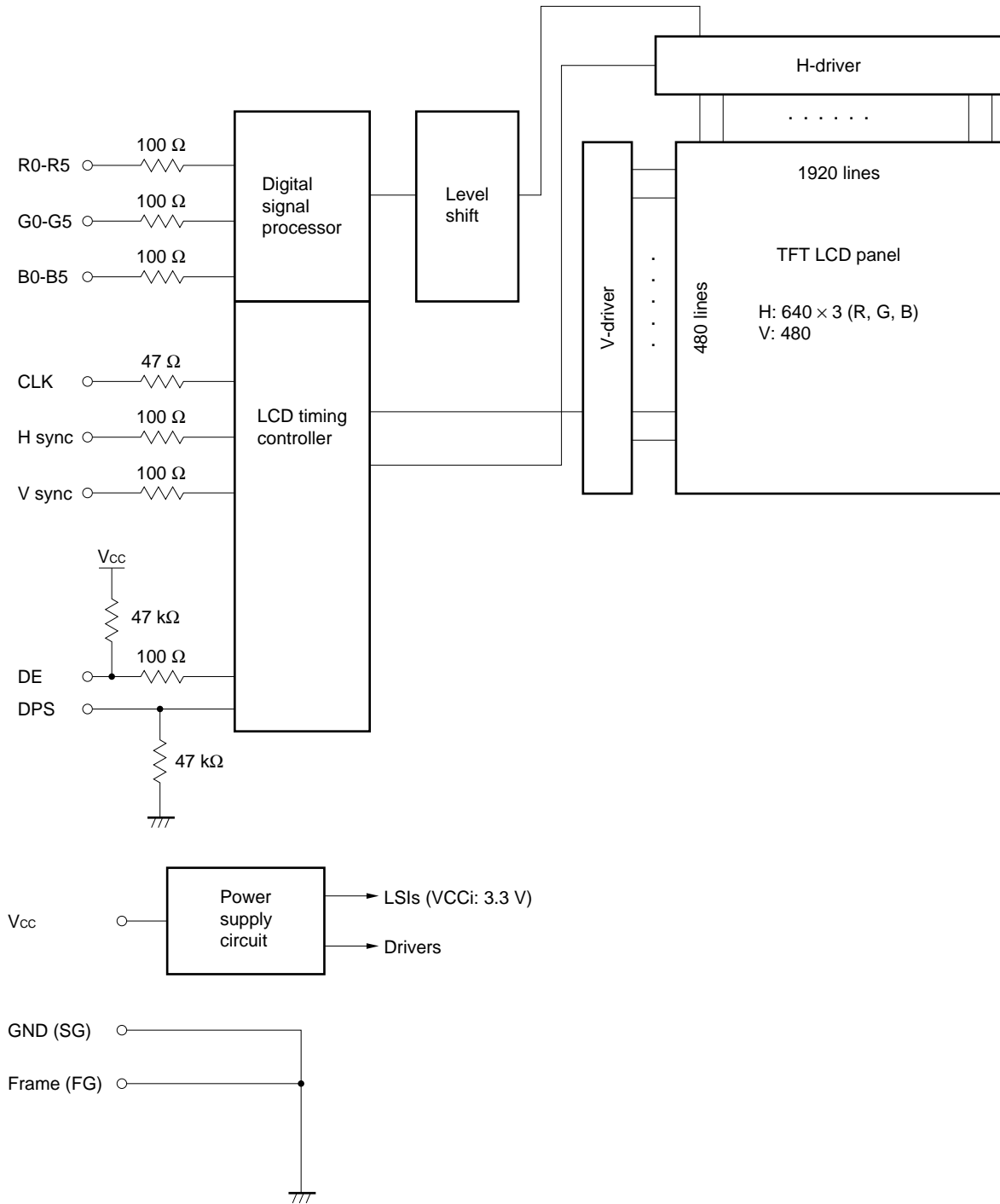

(1) In case of use NEC recommended inverter

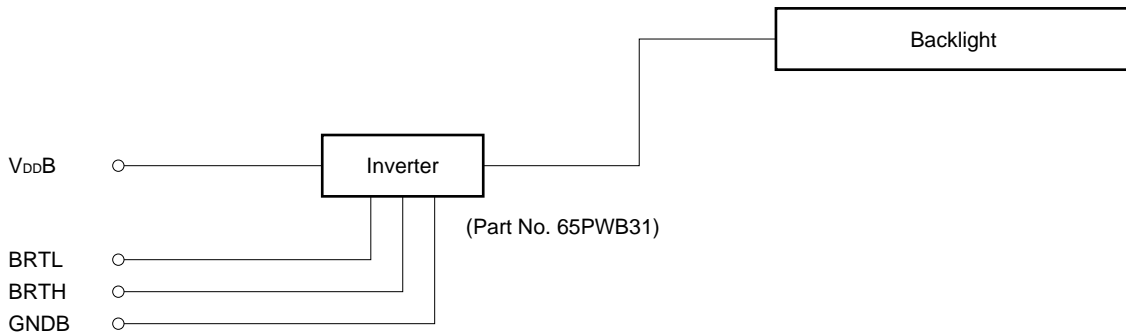

(2) In case of use the inverter of customers

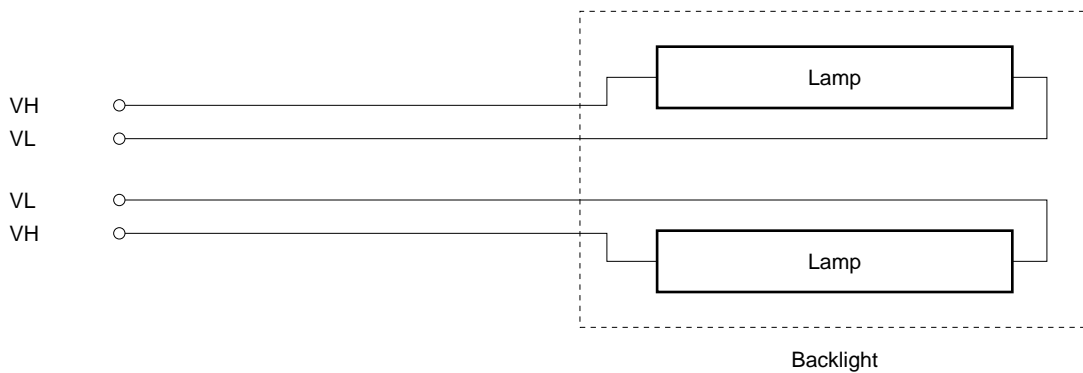

OUTLINE OF CHARACTERISTICS (at room temperature)

Display area	132.48 (H) × 99.36 (V) mm
Drive system	a-Si TFT active matrix
Display colors	262144
Number of pixels	640 × 480
Pixel arrangement	RGB vertical stripe
Pixel pitch	0.207 (H) × 0.207 (V) mm
Module size	178.8 (H) × 126.8 (V) × 11.0 typ. (D) mm
Weight	240 g (typ.)
Contrast ratio	250:1 (typ.)
Viewing angle (more than the contrast ratio of 10:1)	
• Horizontal	: 50° (typ. left side, right side)
• Vertical	: 35° (typ. up side), 45° (typ. down side)
Designed viewing direction	
• wider viewing angle with contrast ratio	: up side (12 o'clock, reverse scan) : down side (6 o'clock, normal scan)
• wider viewing angle without image reversal	: up side (12 o'clock, normal scan) : down side (6 o'clock, reverse scan)
Polarizer pencil-hardness	2H (min. at JIS K5400)
Color gamut	42% (typ. center to NTSC)
Response time	16 ms (typ.) "white" to "black"
Luminance	300 cd/m ² (typ.)
Signal system	6-bit digital signals for each of RGB primary colors, Synchronous signals (Hsync, Vsync), Dot clock (CLK)
Supply voltage	5.0 V (3.3 V) (Logic, LCD driving)
Backlight	Edge light type: two fluorescent lamps (cold cathode type)
Power consumption	5.0 W (typ., at 300 cd/m ² , not include inverter less)

GENERAL SPECIFICATIONS

Item	Specifications	Unit
Module size	178.8 ± 0.5 (H) × 126.8 ± 0.5 (V) × 11.5 max. (D)	mm
Display area	132.48 (H) × 99.36 (V)	mm
Number of pixels	640 (H) × 480 (V)	pixel
Dot pitch	0.069 (H) × 0.207 (V)	mm
Pixel pitch	0.207 (H) × 0.207 (V)	mm
Pixel arrangement	RGB (Red, Green, Blue) vertical stripe	–
Display colors	262144	color
Weight	260 (max.)	g

ABSOLUTE MAXIMUM RATINGS

Parameter	Symbol	Rating	Unit	Remarks
Supply voltage	V _{CC}	–0.3 to 6.5	V	Ta = 25°C Vi – V _{CC} < 3.0
	V _{DD}	–0.3 to 6.5	V	
Input voltage	Vi	–0.3 to V _{CC} + 0.3	V	
Lamp voltage	V _L	1600	V _{rms}	–
Storage temp.	T _{ST}	–25 to 70	°C	–
Operating temp.	T _{OP}	0 to 60	°C	module surface Note
Humidity (no condensation)	RH	≤ 95% relative humidity		Ta ≤ 40°C
		≤ 85% relative humidity		40 < Ta ≤ 50°C
		Absolute humidity shall not exceed Ta = 50°C, 85% relative humidity level.		Ta > 50°C

Note measured at the display area

ELECTRICAL CHARACTERISTICS

(1) Logic, LCD driving

Ta = 25°C

Parameters	Symbols	Min.	Typ.	Max.	Unit.	Remarks
Supply voltage	V _{CC}	4.75 (3.0)	5.0 (3.3)	5.25 (3.6)	V	–
Logic input “L” voltage	V _{IL}	0	–	V _{CCi} × 0.3	V	CMOS level Note 2
Logic input “H” voltage	V _{IH}	V _{CCi} × 0.7	–	V _{CC}	V	
Supply current	I _{CC}	–	200 ^{Note 1} (320)	450 (600)	mA	V _{CC} = 5.0 V (V _{CC} = 3.3 V)

Notes 1. Checker flag pattern (in EIAJ ED-2522)

2. V_{CCi} = 3.3 V : V_{CCi} is given by DC/DC converter in the LCD module.

INTERFACE PIN CONNECTION

Module side connector
 CN31 IL-310-T31PB-VF (No. 1 to 31)
 Supplier: Japan Aviation Electronics
 Industry Limited (JAE)

Mating connector
 IL-310-T31S-VF
 or
 DF9-31S-1V or DF9M-31S-1R
 Supplier: HIROSE ELECTRIC CO., LTD

(1) 6-bit interface signals, power supply

Pin No.	Symbols	Function
1	GND	Ground
2	CLK	Dot clock
3	Hsync	Horizontal synchronous
4	Vsync	Vertical synchronous
5	GND	Ground
6	R0	Red data (LSB)
7	R1	Red data
8	R2	Red data
9	R3	Red data
10	R4	Red data
11	R5	Red data (MSB)
12	GND	Ground
13	G0	Green data (LSB)
14	G1	Green data
15	G2	Green data
16	G3	Green data

Pin No.	Symbols	Function
17	G4	Green data
18	G5	Green data (MSB)
19	GND	Ground
20	B0	Blue data (LSB)
21	B1	Blue data
22	B2	Blue data
23	B3	Blue data
24	B4	Blue data
25	B5	Blue data (MSB)
26	GND	Ground
27	DE	Data enable
28	Vcc	Power supply
29	Vcc	Power supply
30	N.C.	Non-connection (Open)
31	DPS	Scan Direction select

LSB : Least Significant Bit
 MSB: Most Significant Bit

- Notes**
1. Vcc : All Vcc terminals should be connected to Vcc.
 2. DPS: Normal scan is "L" or "Open". And reverse scan is "H".
 3. During the operation, do not change the operation mode: e.g. scan direction.

3. Connector location

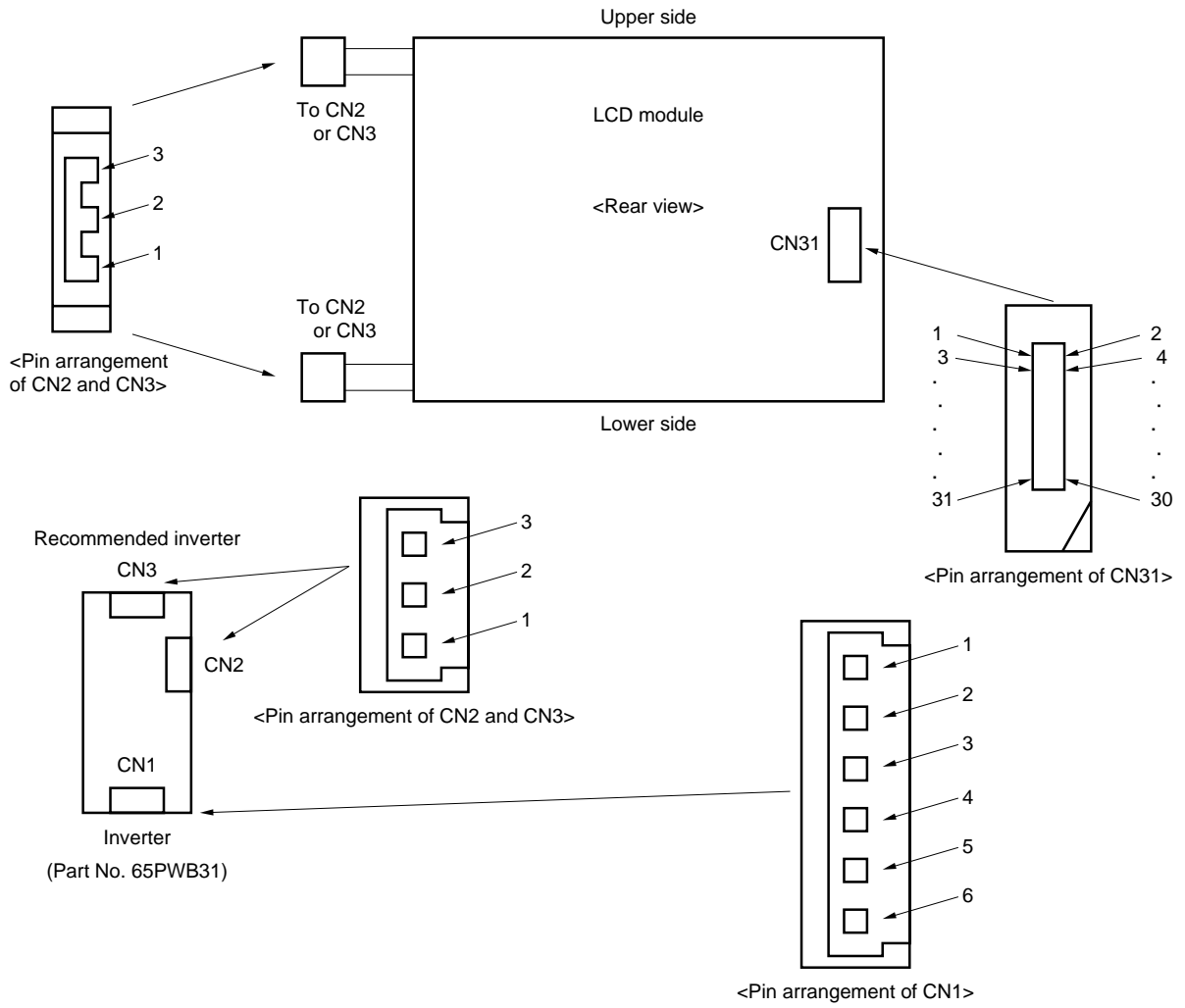

DISPLAY COLORS vs. INPUT DATA SIGNALS

(1) 6-bit interface signals

Display colors		Data signals (0: Low level, 1: High level)																	
		R5	R4	R3	R2	R1	R0	G5	G4	G3	G2	G1	G0	B5	B4	B3	B2	B1	B0
Basic colors	Black	0	0	0	0	0	0	0	0	0	0	0	0	0	0	0	0	0	0
	Blue	0	0	0	0	0	0	0	0	0	0	0	0	1	1	1	1	1	1
	Red	1	1	1	1	1	1	0	0	0	0	0	0	0	0	0	0	0	0
	Magenta	1	1	1	1	1	1	0	0	0	0	0	0	1	1	1	1	1	1
	Green	0	0	0	0	0	0	1	1	1	1	1	1	0	0	0	0	0	0
	Cyan	0	0	0	0	0	0	1	1	1	1	1	1	1	1	1	1	1	1
	Yellow	1	1	1	1	1	1	1	1	1	1	1	1	0	0	0	0	0	0
	White	1	1	1	1	1	1	1	1	1	1	1	1	1	1	1	1	1	1
Red grayscale	Black	0	0	0	0	0	0	0	0	0	0	0	0	0	0	0	0	0	0
		0	0	0	0	0	1	0	0	0	0	0	0	0	0	0	0	0	0
	Dark	0	0	0	0	1	0	0	0	0	0	0	0	0	0	0	0	0	0
	↑																		
	↓																		
	Bright	1	1	1	1	0	1	0	0	0	0	0	0	0	0	0	0	0	0
	1	1	1	1	1	0	0	0	0	0	0	0	0	0	0	0	0	0	
	Red	1	1	1	1	1	1	0	0	0	0	0	0	0	0	0	0	0	0
Green grayscale	Black	0	0	0	0	0	0	0	0	0	0	0	0	0	0	0	0	0	0
		0	0	0	0	0	0	0	0	0	0	0	1	0	0	0	0	0	0
	Dark	0	0	0	0	0	0	0	0	0	0	1	0	0	0	0	0	0	0
	↑																		
	↓																		
	Bright	0	0	0	0	0	0	1	1	1	1	0	1	0	0	0	0	0	0
	0	0	0	0	0	0	1	1	1	1	1	0	0	0	0	0	0	0	
	Green	0	0	0	0	0	0	1	1	1	1	1	1	0	0	0	0	0	0
Blue grayscale	Black	0	0	0	0	0	0	0	0	0	0	0	0	0	0	0	0	0	0
		0	0	0	0	0	0	0	0	0	0	0	0	0	0	0	0	0	1
	Dark	0	0	0	0	0	0	0	0	0	0	0	0	0	0	0	0	1	0
	↑																		
	↓																		
	Bright	0	0	0	0	0	0	0	0	0	0	0	0	1	1	1	1	0	1
	0	0	0	0	0	0	0	0	0	0	0	0	1	1	1	1	1	0	
	Blue	0	0	0	0	0	0	0	0	0	0	0	0	1	1	1	1	1	1

Note Colors are developed in combination with 6 bit signal (64 steps in grayscale) of each primary red, green, and blue color.

This process can result in up to 262144 (64 × 64 × 64) colors.

INPUT SIGNAL TIMING

(1) Input signal specifications

Parameters		Symbols	Min.	Typ.	Max.	Unit	Remarks	
CLK	Frequency	1/tc	21.0	25.175	29.0	MHz	39.722 ns (typ.)	
	Duty	tch/tc	0.4	0.5	0.6	–	–	
	Rise, fall	tcrf	–	–	10	ns	–	
Hsync	Period	th	30.0	31.778	33.6	μs	31.468 kHz (typ.)	
			–	800	–	CLK		
	Display period	thd	–	25.422	–	μs	–	
			–	640	–	CLK		
	Front-porch	thf	–	0.636	–	μs	–	
			0	16	–	CLK		
	Pulse width	thp	–	3.813	–	μs	–	
			10	96	–	CLK		
	Back-porch	thb	–	1.907	–	μs	–	
			5	48	–	CLK		
	*) thp + thb			64	144	–	CLK	–
	CLK-Hsync timing	thch		12	–	–	ns	–
Hsync-CLK timing	thcs		8	–	–	ns	–	
Hsync-Vsync timing	tvh		15	–	–	ns	–	
Vsync-Hsync timing	tvS		15	–	–	ns	–	
Rise, fall	thrf		–	–	10	ns	–	
Vsync	Period	tv	16.1	16.683	17.2	ms	59.94 Hz (typ.)	
			–	525	–	H		
	Display period	tvd	–	15.253	–	ms	–	
			–	480	–	H		
	Front-porch	tvf	–	0.381	–	ms	–	
			1	12	–	H		
	Pulse width	tvp	–	0.063	–	ms	–	
			2	2	–	H		
Back-porch	tvb	–	0.985	–	ms	–		
		4	31	–	H			
*) tvp + tvb			6	33	–	H	–	
Rise, fall			–	–	10	ns	–	
DATA R0 to R5 G0 to G5 B0 to B5	CLK-DATA timing	tds	8	–	–	ns	–	
	DATA-CLK timing	tdh	12	–	–	ns	–	
	Rise, fall	tdrf	–	–	10	ns	–	
DE	DE-CLK timing	tes	8	–	–	ns	–	
	CLK-DE timing	teh	12	–	–	ns		
	Rise, fall	terf	–	–	10	ns		

Note All parameters should be kept within the specified range.

(2) Definition of input signal timing

<Vertical>

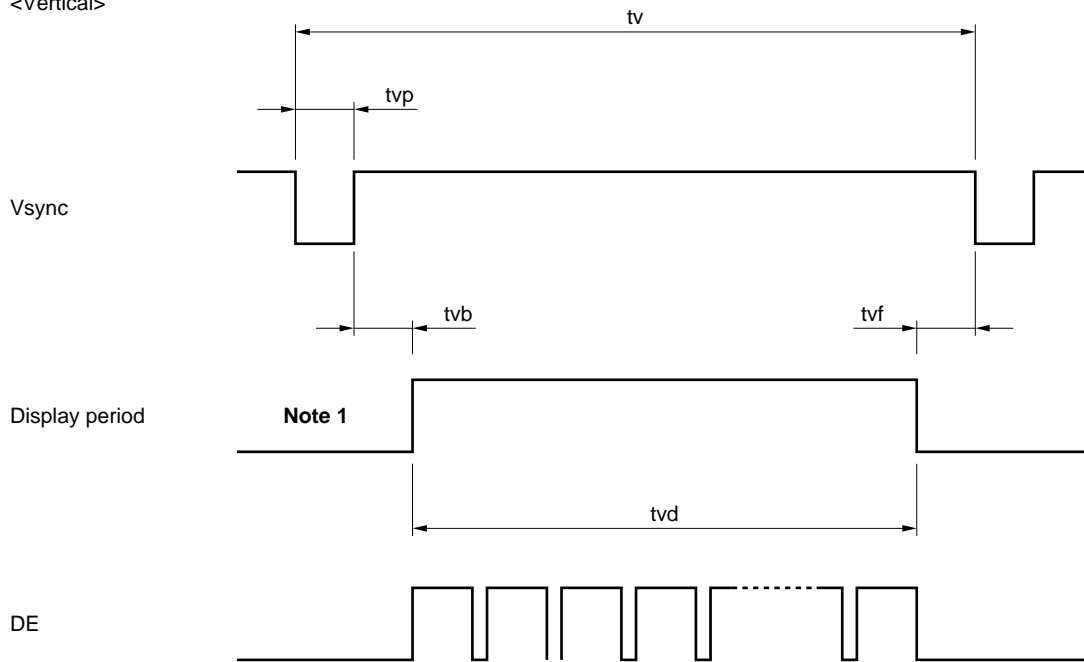

<Horizontal>

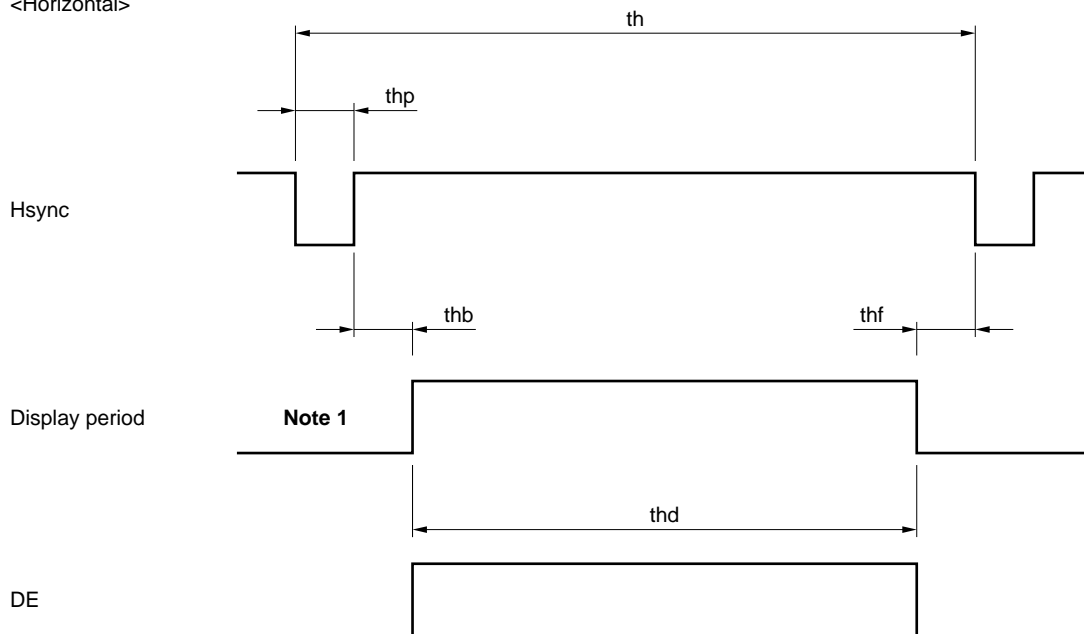

- Notes**
1. Display period does not exist as signals.
 2. Set the total of $thp + thb$ and $tvp + tvb$ as the table of input signal timing, otherwise display position is shifted to right or left side, or to up or down side.

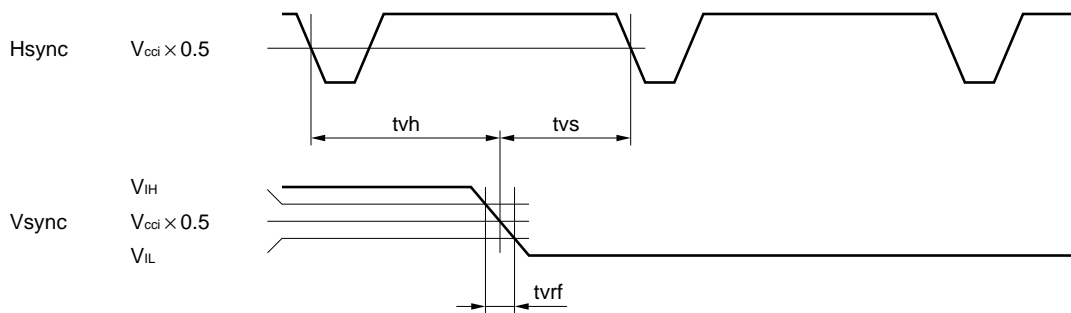
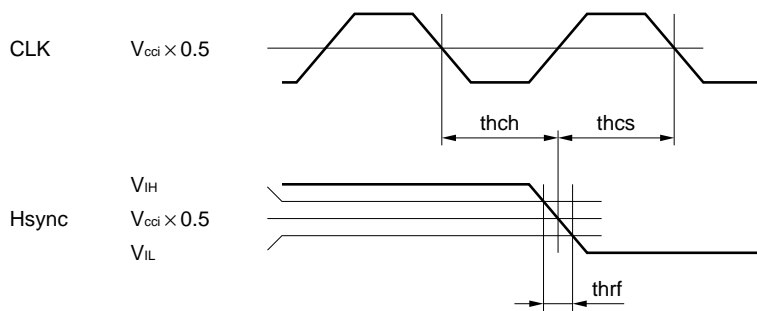
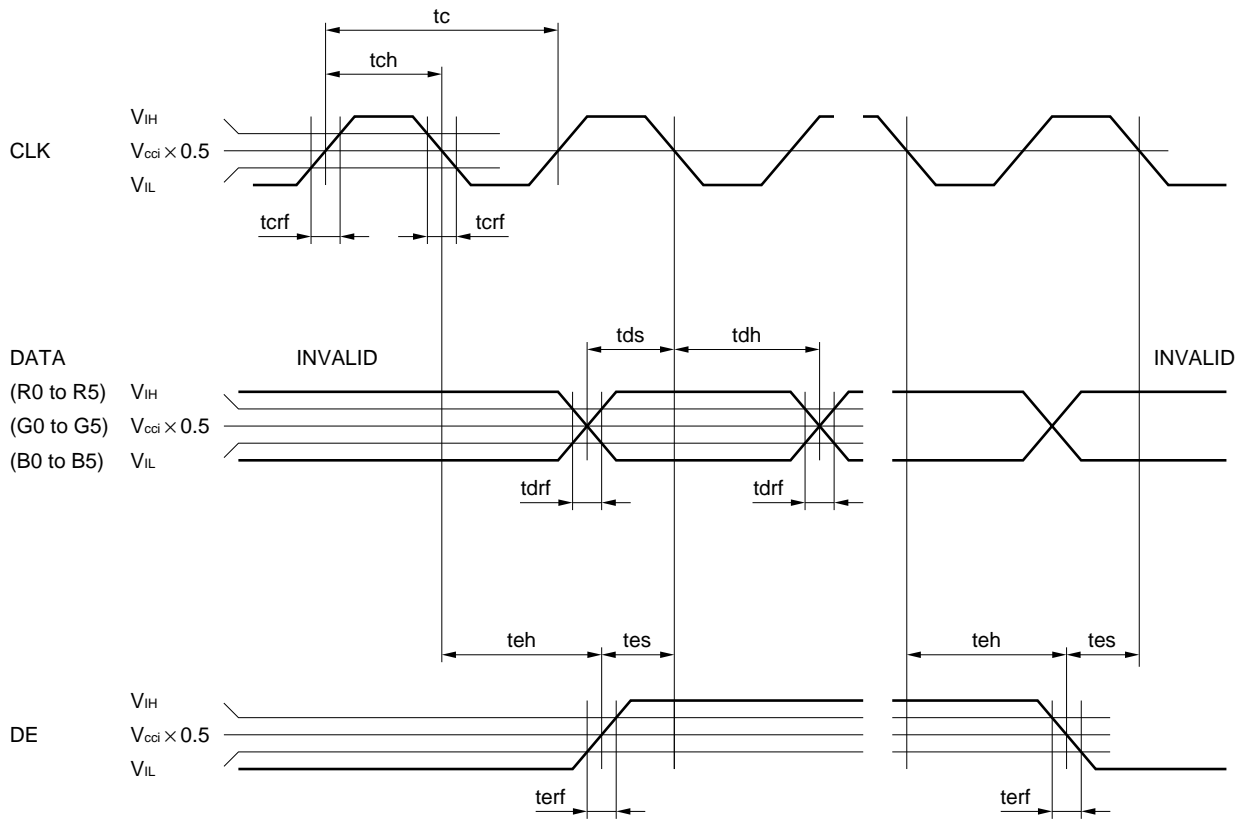

$V_{IH} = V_{CCI} \times 0.7$ (min.)

$V_{IL} = V_{CCI} \times 0.3$ (max.)

$V_{CCI} = 3.3$ V: V_{CCI} is given by DC/DC converter in the LCD module.

(3) Input signal timing chart

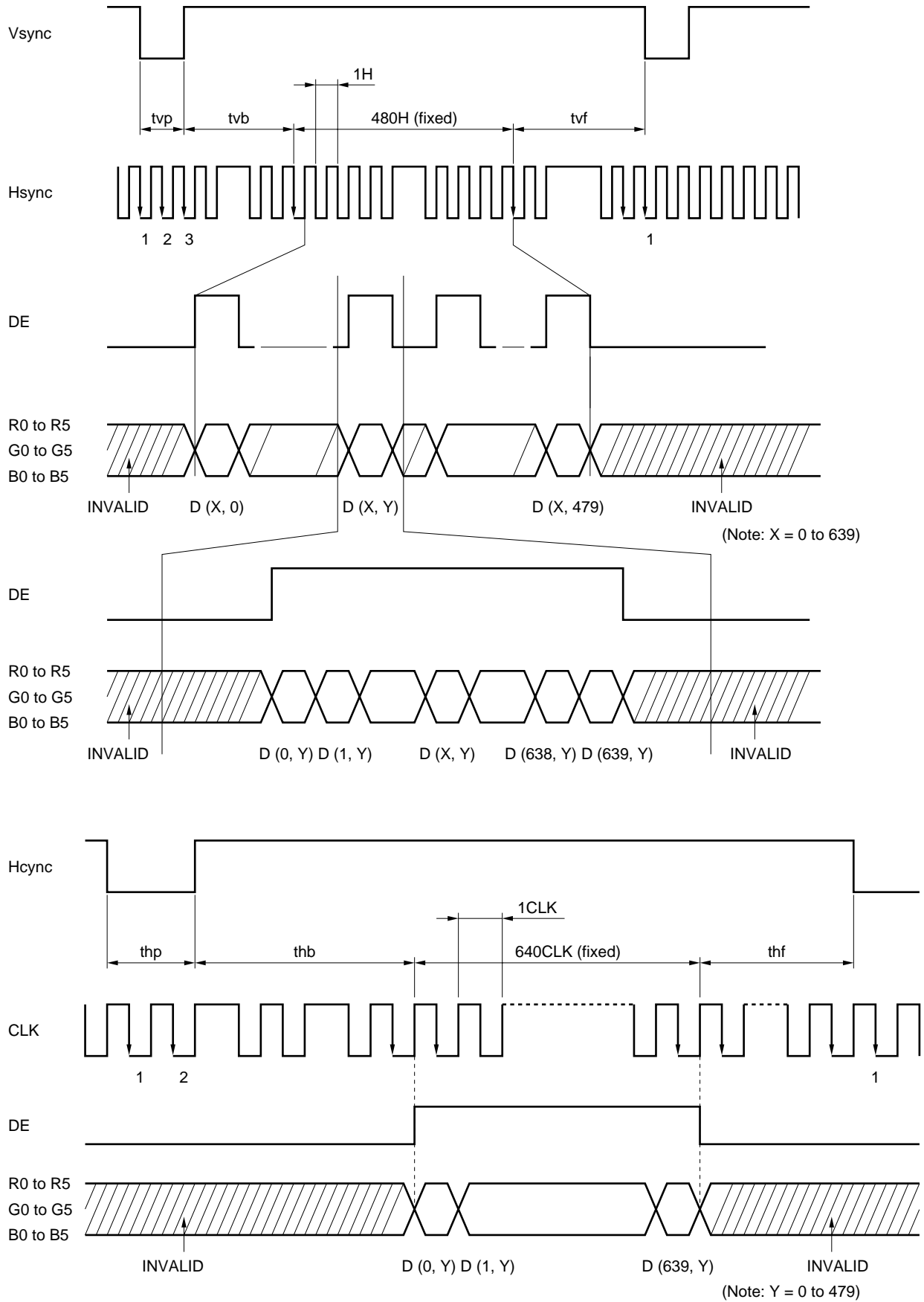

DISPLAY POSITION

Normal scan: DPS = "L" (factory set)

D (0, 0)	D (1, 0)	----	D (X, 0)	----	D (638, 0)	D (639, 0)
D (0, 1)	D (1, 1)	----	D (X, 1)	----	D (638, 1)	D (639, 1)
		+--	+--	+--		
D (0, Y)	D (1, Y)	----	D (X, Y)	----	D (638, Y)	D (639, Y)
		+--	+--	+--		
D (0, 478)	D (1, 478)	----	D (X, 478)	----	D (638, 478)	D (639, 478)
D (0, 479)	D (1, 479)	----	D (X, 479)	----	D (638, 479)	D (639, 479)

Reverse scan: DPS = "H"

D (639, 479)	D (638, 479)	----	D (X, 479)	----	D (1, 479)	D (0, 479)
D (639, 478)	D (638, 478)	----	D (X, 478)	----	D (1, 478)	D (0, 478)
		+--	+--	+--		
D (639, Y)	D (638, Y)	----	D (X, Y)	----	D (1, Y)	D (0, Y)
		+--	+--	+--		
D (639, 1)	D (638, 1)	----	D (X, 1)	----	D (1, 1)	D (0, 1)
D (639, 0)	D (638, 0)	----	D (X, 0)	----	D (1, 0)	D (0, 0)

Note Below drawings show relations between the scan direction and the viewing direction.

Normal scan

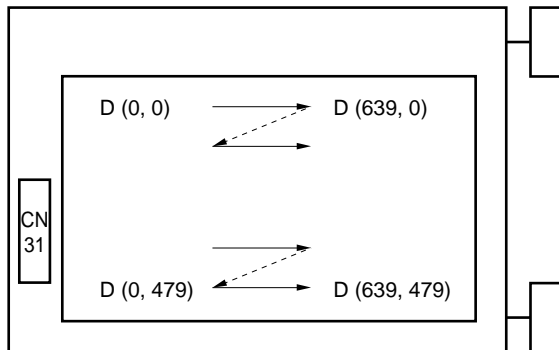

Reverse scan

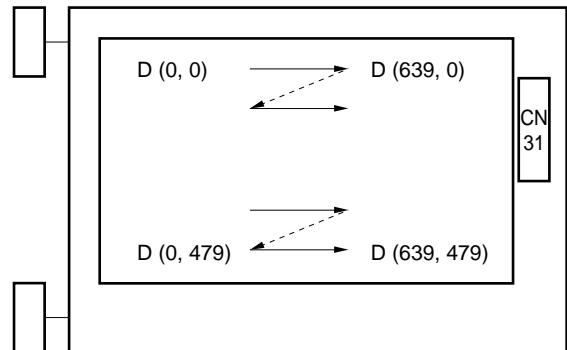

OPTICAL CHARACTERISTICS

Ta = 25°C **Note 1**

Parameters	Symbols	Conditions	Min.	Typ.	Max.	Unit	Remarks
Contrast ratio	CR	Note 2	150	250	–	–	Note 3
Luminance	Lu	Note 2	250	300	–	cd/m ²	Note 4
Luminance uniformity	–	max./min.	–	–	1.25	–	Note 5

Reference data

Parameters	Symbols	Conditions	Min.	Typ.	Max.	Unit	Remarks	
Response time	t on	White to black	–	16	40	ms	Note 6	
	t off	Black to white	–	55	90	ms		
Color gamut	C	at center, to NTSC	35	42	–	%	–	
Viewing angle range	Horizontal	θ_{x+}	CR > 10, $\theta_y = \pm 0^\circ$	45	50	–	deg.	Note 7
		θ_{x-}	CR > 10, $\theta_y = \pm 0^\circ$	45	50	–	deg.	
	Vertical	θ_{y+}	CR > 10, $\theta_x = \pm 0^\circ$	30	35	–	deg.	
		θ_{y-}	CR > 10, $\theta_x = \pm 0^\circ$	40	45	–	deg.	

- Notes**
1. Vcc = 5.0 V, IL = 5.0 mA rms, with NEC recommended inverter (Part No.65PWB31).
 2. Viewing angle: $\theta_x = \pm 0^\circ$, $\theta_y = \pm 0^\circ$, At center.
Best contrast angle: $\theta_x = \pm 0^\circ$, $\theta_y = -10^\circ$, At center.
 3. The contrast ratio is calculated by using the following formula.

$$\text{Contrast ratio (CR)} = \frac{\text{Luminance with all pixels in "white"}}{\text{Luminance with all pixels in "black"}}$$

The Luminance is measured in darkroom.

4. The luminance is measured after 20 minutes from the module works, with all pixels in "white". Typical value is measured after luminance saturation.

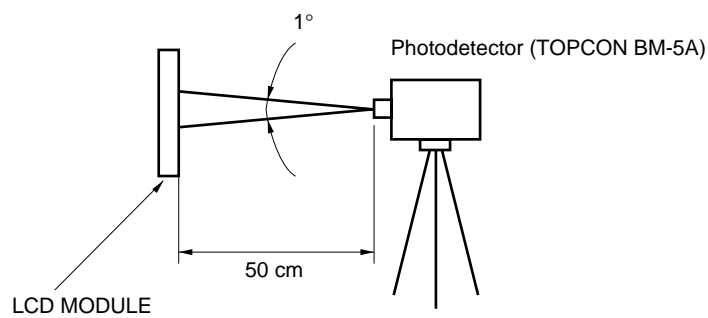

5. The luminance uniformity is calculated by using following formula.

$$\text{Luminance uniformity} = \frac{\text{Maximum luminance}}{\text{Minimum luminance}}$$

The luminance is measured at near the five points shown below.

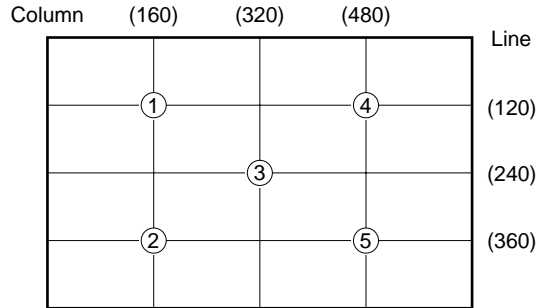

6. Definition of response time is as follows.

Photodetector output signal is measured when the Luminance changes “white” to “black”. Response time is the time between 10% and 100% of the photodetector output amplitude.

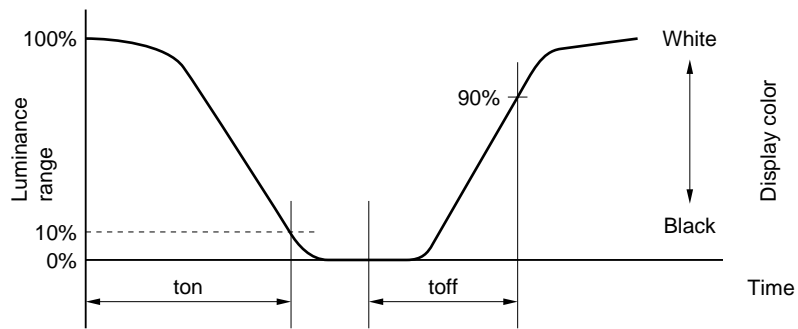

7. Definitions of viewing angle are as follows.

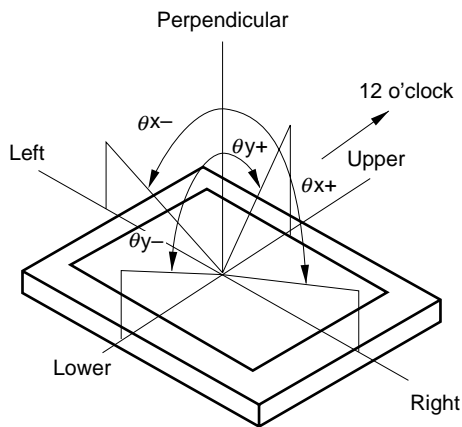

RELIABILITY TEST

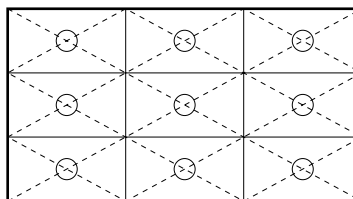

No.	Test items	Test conditions	Judgement
1.	High temperature/humidity operation	50 ± 2°C, 85% relative humidity 240 hours Display data is black.	Note 1
2.	High temperature (operation)	60 ± 3°C 240 hours Display data is black.	Note 1
3.	Heat cycle (operation)	<1> 0°C ± 3°C ... 1 hour 55°C ± 3°C ... 1 hour <2> 50 cycles, 4 hours/cycle <3> Display data is black.	Note 1
4.	Thermal shock (non-operation)	<1> -25°C ± 3°C ... 30 minutes 70°C ± 3°C ... 30 minutes <2> 100 cycles <3> Temperature transition time within 5 minutes	Note 1
5.	Vibration (non-operation)	<1> 5 - 100 Hz, 2G 1 minute/cycle, X, Y, Z direction <2> 120 times each direction	Note 1 Note 2
6.	Mechanical shock (non-operation)	<1> 55 G, 11 ms X, Y, Z direction <2> 5 times each direction	Note 1 Note 2
7.	ESD (operation)	150 pF, 150 Ω, ±10 kV 9 places on a panel 10 times each place at one-second intervals	Note 1 Note 3
8.	Dust (operation)	15 kinds of dust (JIS Z 8901) Hourly 15 seconds stir, 8 times repeat	Note 1

- Notes**
1. Display function is checked by the same condition as LCD module out-going inspection.
 2. Physical damage.
 3. Discharge points are shown in the figure.



GENERAL CAUTIONS

Next figures and sentence are very important, please understand these contents as follows.

 <p>CAUTION</p>	<p>This figure is a mark that you will get hurt and/or the module will have damages when you make a mistake to operate.</p>
	<p>This figure is a mark that you will get an electric shock when you make a mistake to operate.</p>
	<p>This figure is a mark that you will get hurt when you make a mistake to operate</p>

 **CAUTION**

(1) Caution when taking out the module

- <1> Pick the pouch only, when taking out the module from a carrier box.

(2) Cautions for handling the module

- <1> As the electrostatic discharges may break the LCD module, handle the LCD module with care against electrostatic discharges.
- <2>  As the LCD panel and backlight element are made from fragile glass material, impulse and pressure to the LCD module should be avoided.
- <3> As the surface of polarizer is very soft and easily scratched, use a soft dry cloth without chemicals for cleaning.
- <4> Do not pull the interface connectors in or out while the LCD module is operating.
- <5> Put the module display side down on a flat horizontal plane.
- <6> Handle connectors and cables with care.
- <7> When the module is operating, do not lose CLK, Hsync, or Vsync signal. If any one or more of these signals is lost, the LCD panel would be damaged.
- <8> The torque for mounting screw should never exceed 0.20 N·m (2 kgf·cm).

(3) Cautions for the atmosphere

- <1> Dew drop atmosphere must be avoided.
- <2> Do not store and/or operate the LCD module in high temperature and/or high humidity atmosphere. Storage in an electro-conductive polymer packing pouch and under relatively low temperature atmosphere is recommended.
- <3> This module uses cold cathod fluorescent lamps. Therefore, the life time of lamp becomes short conspicuously at low temperature.
- <4> Do not operate the LCD module in high magnetic field.

(4) Caution for the module characteristics

- <1> Do not apply any fixed patterns data signal to the LCD module at product aging. Applying fixed pattern for a long time may cause image sticking.
- <2> This module has the retardation film which may cause the variation of the color hue in the different viewing angles. The ununiformity may appear on the screen under the high temperature operation.

(5) Other cautions

- <1> Do not disassemble and/or reassemble LCD module.
- <2> Do not readjust variable resistors nor switches etc.
- <3> When returning the module for repair or etc, pack the module not to be broken. We recommend the original shipping packages.

Liquid Crystal Display has the following specific characteristics. There are not defects nor malfunctions.
The display condition of the LCD module may be affected by the ambient temperature.
The LCD module uses cold cathode tube for backlighting. Optical characteristics, like luminance or uniformity, will change during time.
Uneven brightness and/or small spots may be noticed depending on different display patterns.

OUTLINE DRAWING/FRONT SIDE (Unit in mm)

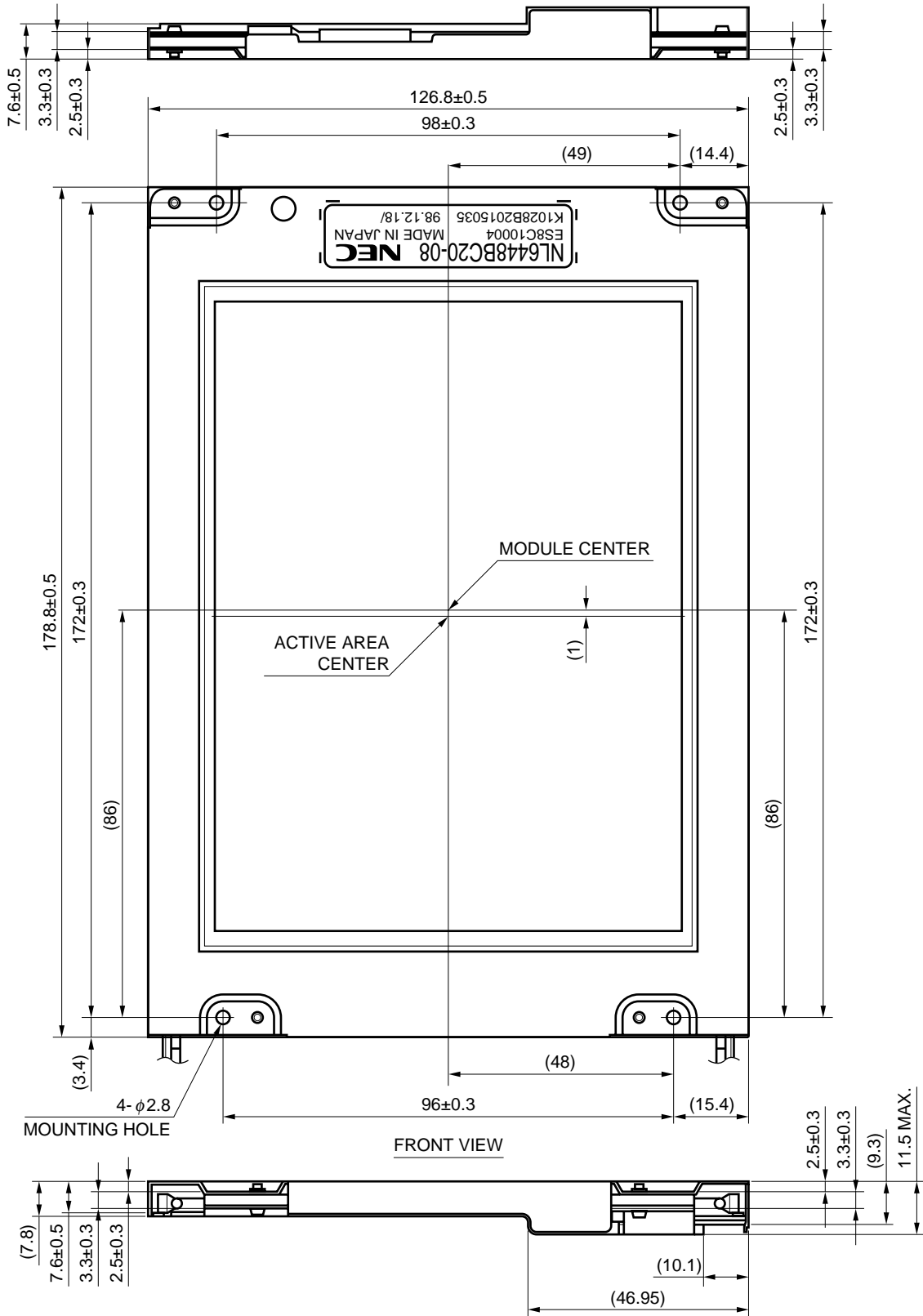

OUTLINE DRAWING/REAR SIDE (Unit in mm)

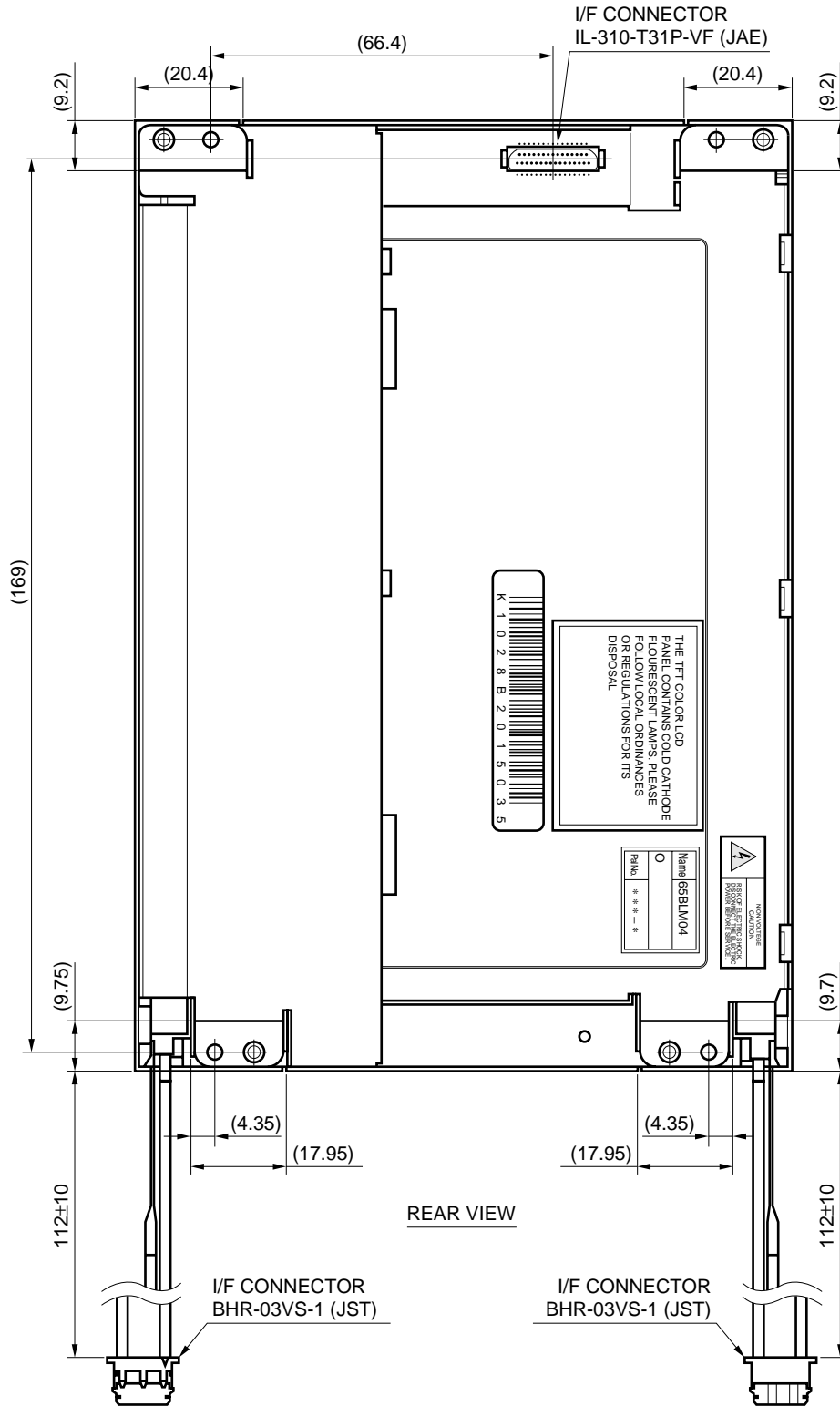

- Notes**
1. Not shown tolerances of the dimensions are ±0.5 mm.
 2. The value in parentheses are for reference.

No part of this document may be copied or reproduced in any form or by any means without the prior written consent of NEC Corporation. NEC Corporation assumes no responsibility for any errors which may appear in this document.

NEC Corporation does not assume any liability for infringement of patents. Copyrights or other intellectual property rights of third parties by or arising from use of a device described herein or any other liability arising from use of such device. No license, either express, implied or otherwise, is granted under any patents, copyrights or other intellectual property rights of NEC Corporation or others.

While NEC Corporation has been making continuous effort to enhance the reliability of its Electronic Components, the possibility of defects cannot be eliminated entirely. To minimize risks of damage or injury to persons or property arising from a defect in an NEC Electronic Components, customers must incorporate sufficient safety measures in its design, such as redundancy, fire-containment, and anti-failure features.

NEC devices are classified into the following three quality grades:

“Standard”, “Special”, and “Specific”. The Specific quality grade applies only to devices developed based on a customer designated “quality assurance program” for a specific application. The recommended applications of a device depend on its quality grade, as indicated below. Customers must check the quality grade of each device before using it in a particular application.

Standard: Computers, office equipment, communications equipment, test and measurement equipment, audio and visual equipment, home electronic appliances, machine tools, personal electronic equipment and industrial robots

Special: Transportation equipment (automobiles, trains, ships, etc.), traffic control systems, anti-disaster systems, anti-crime systems, safety equipment and medical equipment (not specifically designed for life support)

Specific: Aircrafts, aerospace equipment, submersible repeaters, nuclear reactor control systems, life support systems or medical equipment for life support, etc.

The quality grade of NEC devices is “Standard” unless otherwise specified in NEC’s Data Sheets or Data Books. If customers intend to use NEC devices for applications other than those specified for Standard quality grade, they should contact an NEC sales representative in advance.

Anti-radioactive design is not implemented in this product.