

BIPOLAR ANALOG INTEGRATED CIRCUIT

μ PC8172TB

SILICON MMIC 2.5 GHz FREQUENCY UP-CONVERTER FOR WIRELESS TRANSCEIVER

DESCRIPTION

The μ PC8172TB is a silicon monolithic integrated circuit designed as frequency up-converter for wireless transceiver transmitter stage. This IC is manufactured using NEC's 30 GHz f_{max} . UHS0 (Ultra High Speed Process) silicon bipolar process.

This IC is as same circuit current as conventional μ PC8106TB, but operates at higher frequency, higher gain and lower distortion. Consequently this IC is suitable for mobile communications.

FEATURES

- Recommended operating frequency : $f_{RFout} = 0.8$ to 2.5 GHz
- Higher IP_3 : $CG = 9.5$ dB TYP., $OIP_3 = +7.5$ dBm TYP. @ $f_{RFout} = 0.9$ GHz
- High-density surface mounting : 6-pin super minimold package
- Supply voltage : $V_{CC} = 2.7$ to 3.3 V

APPLICATIONS

- PCS1900M
- 2.4 GHz band transmitter/receiver system (wireless LAN etc.)

ORDERING INFORMATION

Part Number	Package	Marking	Supplying Form
μ PC8172TB-E3	6-pin super minimold	C3A	<ul style="list-style-type: none"> • Embossed tape 8 mm wide. • Pin 1, 2, 3 face the tape perforation side. • Qty 3 kpcs/reel.

Remark To order evaluation samples, please contact your local NEC sales office.
(Part number for sample order: μ PC8172TB)

Caution Electro-static sensitive devices

The information in this document is subject to change without notice. Before using this document, please confirm that this is the latest version.
Not all devices/types available in every country. Please check with local NEC representative for availability and additional information.

PIN CONNECTIONS

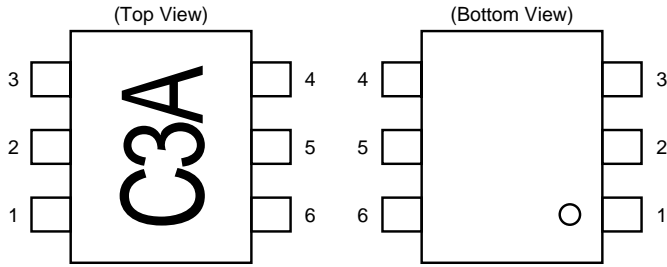

Pin No.	Pin Name
1	IFinput
2	GND
3	LOinput
4	PS
5	V _{cc}
6	RFoutput

SERIES PRODUCTS (T_A = +25°C, V_{CC} = V_{PS} = V_{RFout} = 3.0 V, Z_S = Z_L = 50 Ω)

Part Number	I _{cc} (mA)	f _{RFout} (GHz)	CG (dB)		
			@RF 0.9 GHz ^{Note}	@RF 1.9 GHz	@RF 2.4 GHz
μPC8172TB	9	0.8 to 2.5	9.5	8.5	8.0
μPC8106TB	9	0.4 to 2.0	9	7	–
μPC8109TB	5	0.4 to 2.0	6	4	–
μPC8163TB	16.5	0.8 to 2.0	9	5.5	–

Part Number	P _{O(sat)} (dBm)			OIP ₃ (dBm)		
	@RF 0.9 GHz ^{Note}	@RF 1.9 GHz	@RF 2.4 GHz	@RF 0.9 GHz ^{Note}	@RF 1.9 GHz	@RF 2.4 GHz
μPC8172TB	+0.5	0	–0.5	+7.5	+6.0	+4.0
μPC8106TB	–2	–4	–	+5.5	+2.0	–
μPC8109TB	–5.5	–7.5	–	+1.5	–1.0	–
μPC8163TB	+0.5	–2	–	+9.5	+6.0	–

Note f_{RFout} = 0.83 GHz @ μPC8163TB

Remark Typical performance. Please refer to **ELECTRICAL CHARACTERISTICS** in detail.
To know the associated product, please refer to each latest data sheet.

BLOCK DIAGRAM (FOR THE μPC8172TB)

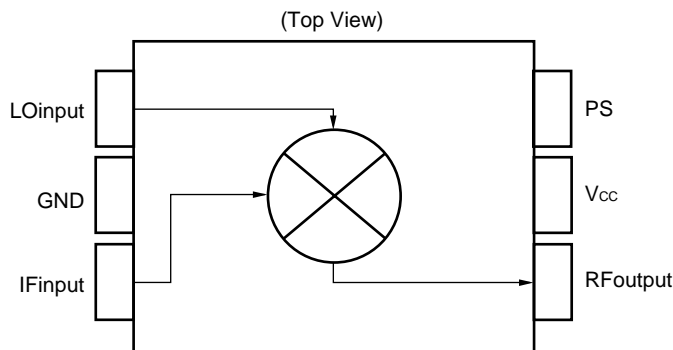

SYSTEM APPLICATION EXAMPLES (SCHEMATICS OF IC LOCATION IN THE SYSTEM)

Wireless Transceiver

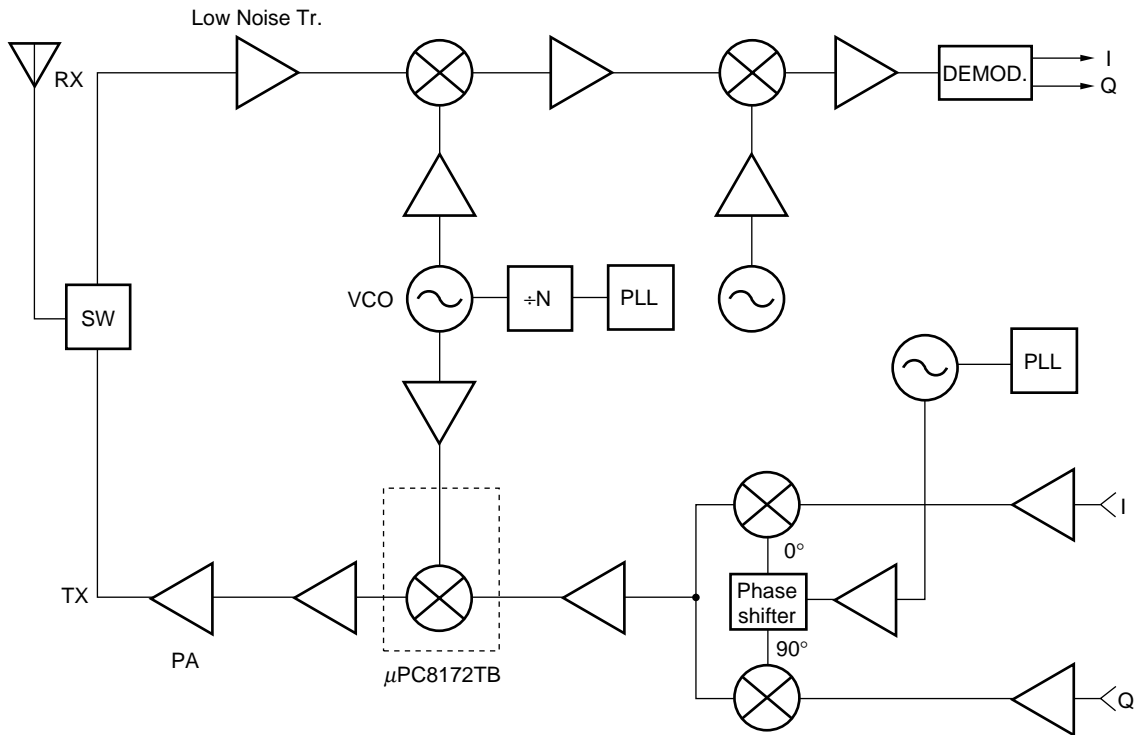

To know the associated products, please refer to each latest data sheet.

PIN EXPLANATION

Pin No.	Pin Name	Applied Voltage (V)	Pin Voltage (V) ^{Note}	Function and Explanation	Equivalent Circuit						
1	IFinput	–	1.4	This pin is IF input to double balanced mixer (DBM). The input is designed as high impedance. The circuit contributes to suppress spurious signal. Also this symmetrical circuit can keep specified performance insensitive to process-condition distribution. For above reason, double balanced mixer is adopted.							
2	GND	GND	–	GND pin. Ground pattern on the board should be formed as wide as possible. Track Length should be kept as short as possible to minimize ground impedance.							
3	LOinput	–	2.3	Local input pin. Recommendable input level is –10 to 0 dBm.							
5	V _{CC}	2.7 to 3.3	–	Supply voltage pin.							
6	RFoutput	Same bias as V _{CC} through external inductor	–	This pin is RF output from DBM. This pin is designed as open collector. Due to the high impedance output, this pin should be externally equipped with LC matching circuit to next stage.							
4	PS	V _{CC} /GND	–	Power save control pin. Bias controls operation as follows. <table border="1" style="margin: 10px auto;"> <thead> <tr> <th>Pin bias</th> <th>Control</th> </tr> </thead> <tbody> <tr> <td>V_{CC}</td> <td>Operation</td> </tr> <tr> <td>GND</td> <td>Power Save</td> </tr> </tbody> </table>	Pin bias	Control	V _{CC}	Operation	GND	Power Save	
Pin bias	Control										
V _{CC}	Operation										
GND	Power Save										

Note Each pin voltage is measured with V_{CC} = V_{PS} = V_{RFout} = 3.0 V.

ABSOLUTE MAXIMUM RATINGS

Parameter	Symbol	Test Conditions	Rating	Unit
Supply Voltage	V _{CC}	T _A = +25°C	3.6	V
PS pin Input Voltage	V _{PS}	T _A = +25°C	3.6	V
Power Dissipation of Package	P _D	Mounted on double-side copperclad 50 × 50 × 1.6 mm epoxy glass PWB (T _A = +85°C)	200	mW
Operating Ambient Temperature	T _A		-40 to +85	°C
Storage Temperature	T _{stg}		-55 to +150	°C
Maximum Input Power	P _{in}		+10	dBm

RECOMMENDED OPERATING CONDITIONS

Parameter	Symbol	Test Conditions	MIN.	TYP.	MAX.	Unit
Supply Voltage	V _{CC}	The same voltage should be applied to pin 5 and 6	2.7	3.0	3.3	V
Operating Ambient Temperature	T _A		-40	+25	+85	°C
Local Input Level	P _{LIn}	Z _s = 50 Ω (without matching)	-10	-5	0	dBm
RF Output Frequency	f _{RFout}	With external matching circuit	0.8	-	2.5	GHz
IF Input Frequency	f _{IFin}		50	-	400	MHz

ELECTRICAL CHARACTERISTICS

(T_A = +25°C, V_{CC} = V_{RFout} = 3.0 V, f_{IFin} = 240 MHz, P_{LIn} = -5 dBm, and V_{PS} ≥ 2.7 V unless otherwise specified)

Parameter	Symbol	Test Conditions ^{Note}	MIN.	TYP.	MAX.	Unit
Circuit Current	I _{CC}	No Signal	5.5	9.0	13	mA
Circuit Current In Power Save Mode	I _{CC(PS)}	V _{PS} = 0 V	-	-	2	μA
Conversion Gain	CG1	f _{RFout} = 0.9 GHz, P _{IFin} = -30 dBm	6.5	9.5	12.5	dB
	CG2	f _{RFout} = 1.9 GHz, P _{IFin} = -30 dBm	5.5	8.5	11.5	dB
	CG3	f _{RFout} = 2.4 GHz, P _{IFin} = -30 dBm	5	8.0	11.0	dB
Saturated RF Output Power	P _{O(sat)1}	f _{RFout} = 0.9 GHz, P _{IFin} = 0 dBm	-2.5	+0.5	-	dBm
	P _{O(sat)2}	f _{RFout} = 1.9 GHz, P _{IFin} = 0 dBm	-3.5	0	-	dBm
	P _{O(sat)3}	f _{RFout} = 2.4 GHz, P _{IFin} = 0 dBm	-4	-0.5	-	dBm

Note f_{RFout} < f_{LIn} @ f_{RFout} = 0.9 GHz
 f_{LIn} < f_{RFout} @ f_{RFout} = 1.9 GHz/2.4 GHz

OTHER CHARACTERISTICS, FOR REFERENCE PURPOSES ONLY

($T_A = +25^\circ\text{C}$, $V_{CC} = V_{RFout} = 3.0\text{ V}$, $P_{Loin} = -5\text{ dBm}$, and $V_{PS} \geq 2.7\text{ V}$ unless otherwise specified)

Parameter		Symbol	Test Conditions ^{Note}	Data	Unit
Output Third-Order Distortion Intercept Point		OIP ₃₁	f _{RFout} = 0.9 GHz	+7.5	dBm
		OIP ₃₂	f _{RFout} = 1.9 GHz		
		OIP ₃₃	f _{RFout} = 2.4 GHz		
			f _{Fin1} = 240 MHz f _{Fin2} = 241 MHz	+6.0	dBm
				+4.0	dBm
Input Third-Order Distortion Intercept Point		IIP ₃₁	f _{RFout} = 0.9 GHz	-2.0	dBm
		IIP ₃₂	f _{RFout} = 1.9 GHz		
		IIP ₃₃	f _{RFout} = 2.4 GHz		
			f _{Fin1} = 240 MHz f _{Fin2} = 241 MHz	-2.5	dBm
				-4.0	dBm
SSB Noise Figure		SSB•NF1	f _{RFout} = 0.9 GHz, f _{Fin} = 240 MHz	9.5	dB
		SSB•NF2	f _{RFout} = 1.9 GHz, f _{Fin} = 240 MHz	10.4	dB
		SSB•NF3	f _{RFout} = 2.4 GHz, f _{Fin} = 240 MHz	10.6	dB
Power Save Response Time	Rise time	T _{PS(rise)}	V _{PS} : GND → V _{CC}	1	μs
	Fall time	T _{PS(fall)}	V _{PS} : V _{CC} → GND	1.5	μs

Note f_{RFout} < f_{Loin} @ f_{RFout} = 0.9 GHz

f_{Loin} < f_{RFout} @ f_{RFout} = 1.9 GHz/2.4 GHz

TEST CIRCUIT 1 ($f_{RFout} = 900\text{ MHz}$)

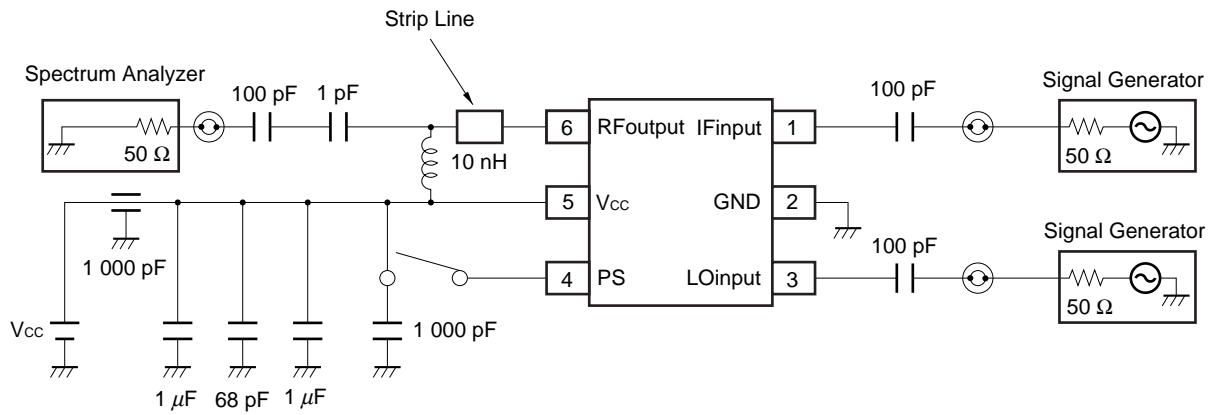

TEST CIRCUIT 2 ($f_{RFout} = 1.9\text{ GHz}$)

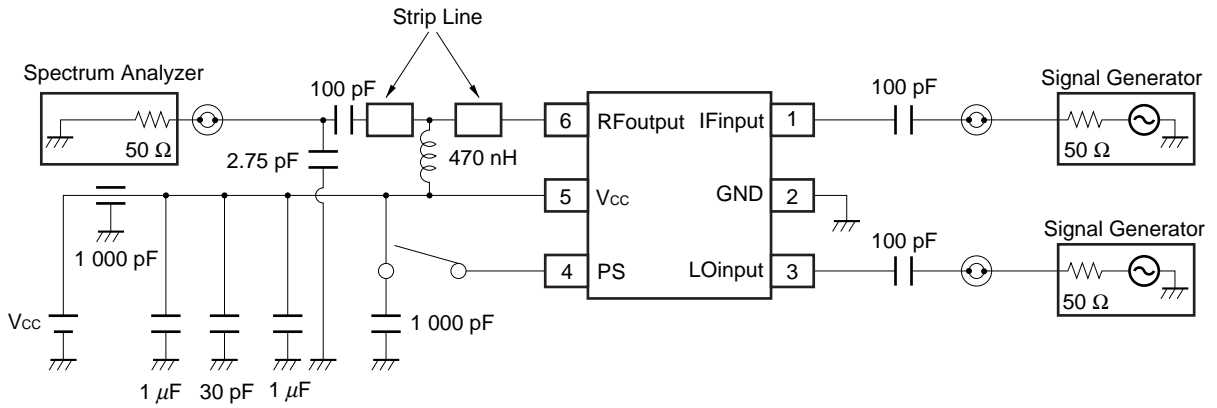

TEST CIRCUIT 3 ($f_{RFout} = 2.4\text{ GHz}$)

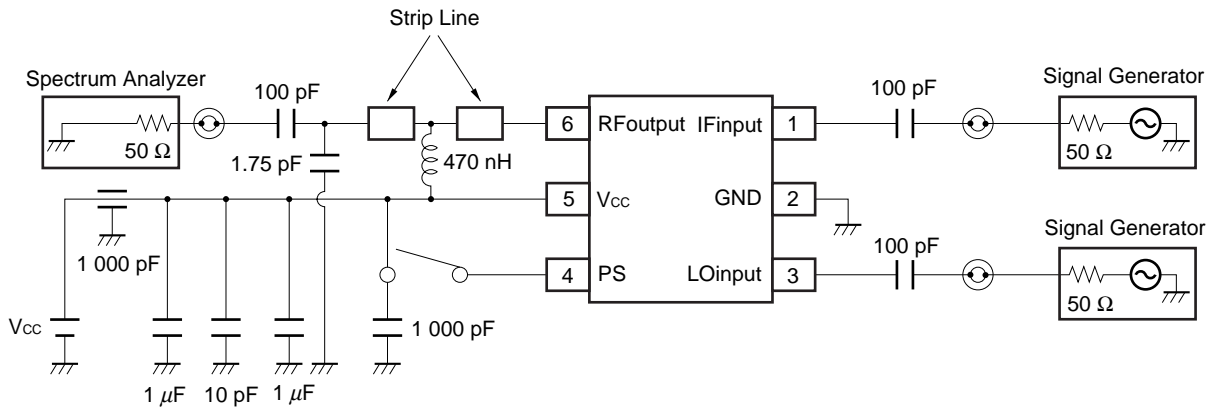

PACKAGE DIMENSIONS

6-pin super minimold (Unit: mm)

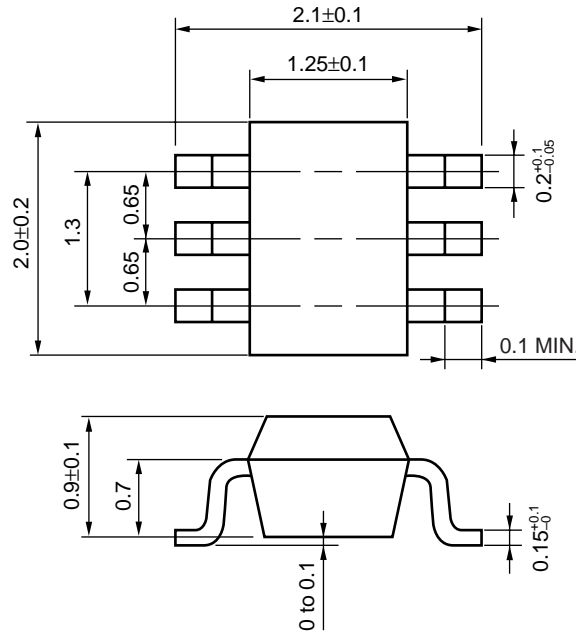

NOTE ON CORRECT USE

- (1) Observe precautions for handling because of electrostatic sensitive devices.
- (2) Form a ground pattern as wide as possible to keep the minimum ground impedance (to prevent undesired oscillation).
- (3) Connect a bypass capacitor (example: 1 000 pF) to the Vcc pin.
- (4) Connect a matching circuit to the RF output pin.
- (5) The DC cut capacitor must be each attached to the input and output pins.

RECOMMENDED SOLDERING CONDITIONS

This product should be soldered under the following recommended conditions. For soldering methods and conditions other than those recommended below, contact your NEC sales representative.

Soldering Method	Soldering Conditions	Recommended Condition Symbol
Infrared Reflow	Package peak temperature: 235°C or below Time: 30 seconds or less (at 210°C) Count: 3, Exposure limit: None ^{Note}	IR35-00-3
VPS	Package peak temperature: 215°C or below Time: 40 seconds or less (at 200°C) Count: 3, Exposure limit: None ^{Note}	VP15-00-3
Wave Soldering	Soldering bath temperature: 260°C or below Time: 10 seconds or less Count: 1, Exposure limit: None ^{Note}	WS60-00-1
Partial Heating	Pin temperature: 300°C Time: 3 seconds or less (per side of device) Exposure limit: None ^{Note}	—

Note After opening the dry pack, keep it in a place below 25°C and 65% RH for the allowable storage period.

Caution Do not use different soldering methods together (except for partial heating).

For details of recommended soldering conditions for surface mounting, refer to information document SEMICONDUCTOR DEVICE MOUNTING TECHNOLOGY MANUAL (C10535E).

[MEMO]

[MEMO]

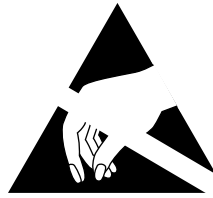

ATTENTION

OBSERVE PRECAUTIONS
FOR HANDLING
ELECTROSTATIC
SENSITIVE
DEVICES

- **The information in this document is current as of June, 2000. The information is subject to change without notice. For actual design-in, refer to the latest publications of NEC's data sheets or data books, etc., for the most up-to-date specifications of NEC semiconductor products. Not all products and/or types are available in every country. Please check with an NEC sales representative for availability and additional information.**
 - No part of this document may be copied or reproduced in any form or by any means without prior written consent of NEC. NEC assumes no responsibility for any errors that may appear in this document.
 - NEC does not assume any liability for infringement of patents, copyrights or other intellectual property rights of third parties by or arising from the use of NEC semiconductor products listed in this document or any other liability arising from the use of such products. No license, express, implied or otherwise, is granted under any patents, copyrights or other intellectual property rights of NEC or others.
 - Descriptions of circuits, software and other related information in this document are provided for illustrative purposes in semiconductor product operation and application examples. The incorporation of these circuits, software and information in the design of customer's equipment shall be done under the full responsibility of customer. NEC assumes no responsibility for any losses incurred by customers or third parties arising from the use of these circuits, software and information.
 - While NEC endeavours to enhance the quality, reliability and safety of NEC semiconductor products, customers agree and acknowledge that the possibility of defects thereof cannot be eliminated entirely. To minimize risks of damage to property or injury (including death) to persons arising from defects in NEC semiconductor products, customers must incorporate sufficient safety measures in their design, such as redundancy, fire-containment, and anti-failure features.
 - NEC semiconductor products are classified into the following three quality grades:
"Standard", "Special" and "Specific". The "Specific" quality grade applies only to semiconductor products developed based on a customer-designated "quality assurance program" for a specific application. The recommended applications of a semiconductor product depend on its quality grade, as indicated below. Customers must check the quality grade of each semiconductor product before using it in a particular application.
 - "Standard": Computers, office equipment, communications equipment, test and measurement equipment, audio and visual equipment, home electronic appliances, machine tools, personal electronic equipment and industrial robots
 - "Special": Transportation equipment (automobiles, trains, ships, etc.), traffic control systems, anti-disaster systems, anti-crime systems, safety equipment and medical equipment (not specifically designed for life support)
 - "Specific": Aircraft, aerospace equipment, submersible repeaters, nuclear reactor control systems, life support systems and medical equipment for life support, etc.
- The quality grade of NEC semiconductor products is "Standard" unless otherwise expressly specified in NEC's data sheets or data books, etc. If customers wish to use NEC semiconductor products in applications not intended by NEC, they must contact an NEC sales representative in advance to determine NEC's willingness to support a given application.

(Note)

- (1) "NEC" as used in this statement means NEC Corporation and also includes its majority-owned subsidiaries.
- (2) "NEC semiconductor products" means any semiconductor product developed or manufactured by or for NEC (as defined above).