

EXTENSION 8-BIT UP/DOWN COUNTER
CMOS INTEGRATED CIRCUITS

DESCRIPTION

The μ PD4704 is 8-bit up/down counters for extension of the μ PD4702 incremental encoder counter. They perform an up/down-count using an 8-bit width with a μ PD4702 carry or borrow signal as input. In addition, a carry output and borrow output are also provided for further extension of the count width, enabling extension to be performed in 8-bit units.

FEATURES

- 8-bit up/down counter for extension of μ PD4702
- Count data output controllable (latch and 3-state output)
- Extension carry and borrow outputs
- CMOS, single +5 V power supply

PIN NAMES

$\overline{\text{Up}}$: Up-count input
$\overline{\text{Down}}$: Down-count input
$\overline{\text{Reset}}$: Counter reset input
$\overline{\text{STB}}$: Latch strobe signal input
$\overline{\text{OE}}$: Output control signal input
$\overline{\text{CD}}_{0-7}$: Count data outputs
$\overline{\text{Carry}}$: Carry pulse output
$\overline{\text{Borrow}}$: Borrow pulse output

ORDERING INFORMATION

Part Number	Package
μ PD4704C	20-pin plastic DIP (300 mil)
μ PD4704G	20-pin plastic SOP (300 mil)

PIN CONFIGURATION (Top View)

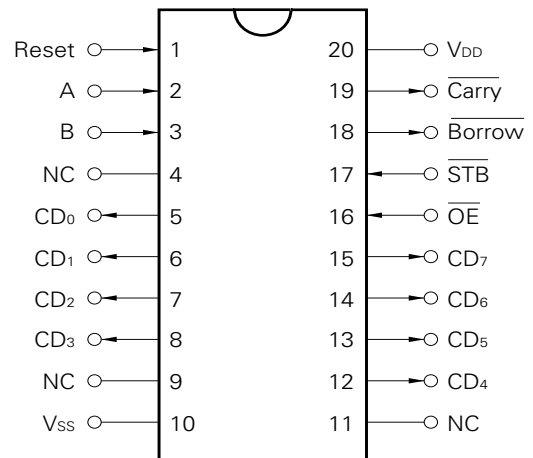

BLOCK DIAGRAM

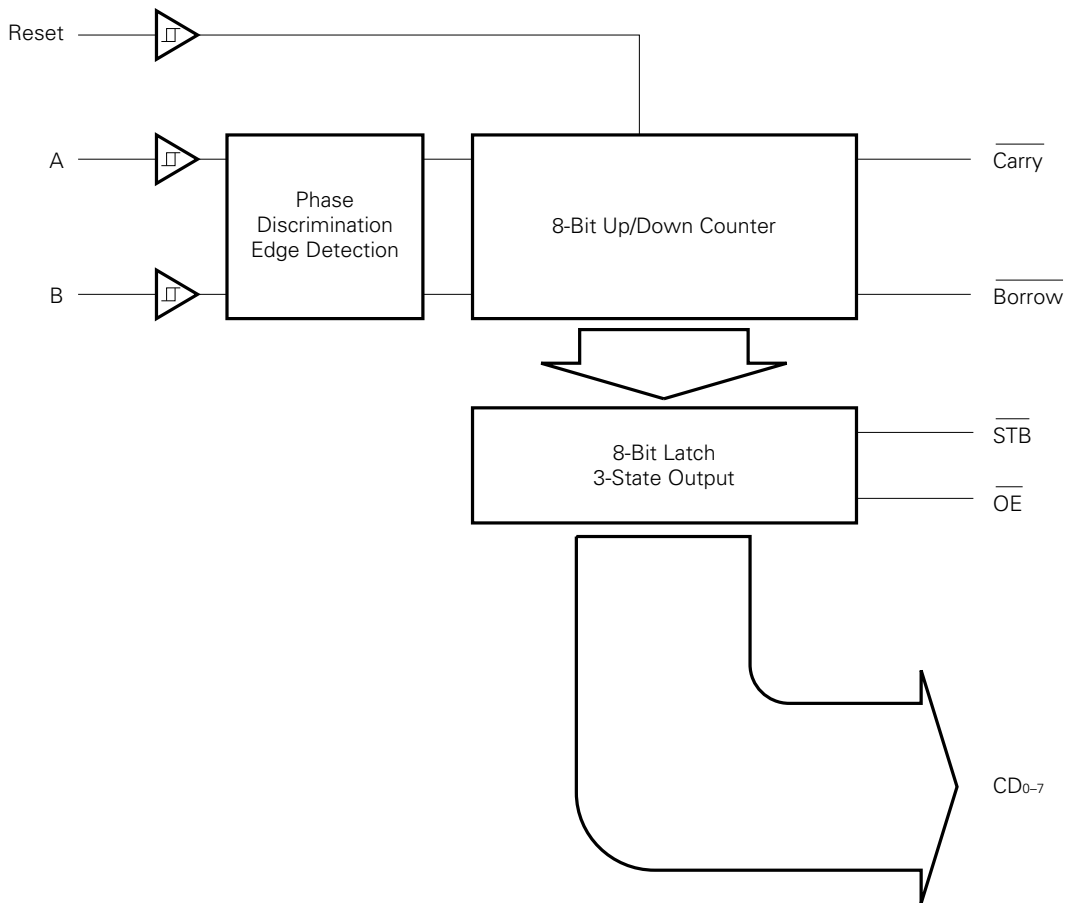

PIN FUNCTIONS

Pin Name	Input/Output	Function
$\overline{\text{Up}}$ $\overline{\text{Down}}$	Input	Up-count & down-count signal input pins Count is performed on rise of signal.
D _{0 to 7}	Output (3-state)	Count data output pins. Activated when $\overline{\text{OE}}$ is "L", high impedance outputs when $\overline{\text{OE}}$ is "H".
$\overline{\text{Carry}}$	Output	8-bit counter carry signal output pin (active-low)
$\overline{\text{Borrow}}$	Output	8-bit counter borrow signal output pin (active-low)
RESET	Input (Schmitt)	8-bit counter reset signal output pin Counter is reset when this pin is "H".
$\overline{\text{OE}}$	Input	Count data output control signal input pin
$\overline{\text{STB}}$	Input	Counter data output latch signal. Data is latched on the fall of $\overline{\text{STB}}$, and is held while $\overline{\text{STB}} = \text{"L"}$.
V _{DD}		Power supply input pin
GND		Ground pin

TRUTH TABLE 1 (COUNTER BLOCK)

× : H or L

\overline{UP}	\overline{DOWN}	RESET	\overline{Carry}	\overline{Borrow}	Remarks
×	×	H	×	×	Reset
H		H	×		Reset
H		L	×	×	Down-count
	H	L	×	×	Up-count
L		L	×	×	Disabled (count undefined)
	L	L	×	×	Disabled (count undefined)
H	L	L	H	L	Borrow output when count = 00H
L	H	L	L	H	Carry output when count = 0FFH

TRUTH TABLE 2 (LATCH & OUTPUT BLOCKS)

× : H or L

\overline{STB}	\overline{OE}	CD ₀ to CD ₇
×	H	Output disable (3-state)
×	L	Output enable
H	×	Data through (count value load)
L	×	Data latch (count value retention)

1. DESCRIPTION OF OPERATIONS

(1) Count operation

The μPD4704 is designed as 8-bit up/down counter for extension of the μPD4702. The first-stage $\overline{\text{Carry}}$ output is connected to the $\overline{\text{UP}}$ input of the μPD4704, and similarly, the $\overline{\text{Borrow}}$ output is connected to the $\overline{\text{DOWN}}$ input. A count is executed on the rising edge of the $\overline{\text{UP}}$ input or $\overline{\text{DOWN}}$ input.

If the μPD4704 is to be used alone, without being connected to the μPD4702, either $\overline{\text{UP}}$ or the $\overline{\text{DOWN}}$ must be "H". If a count pulse is input to $\overline{\text{UP}}$ or $\overline{\text{DOWN}}$ while the other is "L", the count value may change.

(2) Latch operation

An R-S flip-flop is inserted in the latch circuit input as shown in Fig. 1, and when $\overline{\text{STB}}$ is changed from "H" to "L" while the $\overline{\text{UP}}$ or $\overline{\text{DOWN}}$ input is "L", the internal latch signal $\overline{\text{STB}}'$ remains at "H" until the end of the count operation. Therefore, latching is not performed during a count operation. If $\overline{\text{STB}}$ changes from "H" to "L" t_{SUDSTB1} (40 ns) or more after the falling edge of $\overline{\text{UP}}$ or $\overline{\text{DOWN}}$, the post-count data is latched, and if $\overline{\text{STB}}$ changes from "H" to "L" within t_{SUDSTB2} (10 ns) after the falling edge of $\overline{\text{UP}}$ or $\overline{\text{DOWN}}$, then conversely, the pre-count data is latched.

Caution is required since, when $\overline{\text{UP}}$ or $\overline{\text{DOWN}}$ is "L" (during a count operation), the latch operation is kept waiting even if $\overline{\text{STB}}$ is changed from "H" to "L", and therefore if a reset is executed the latch contents will also be reset (see Figs. 2 and 3).

Fig. 1 $\overline{\text{STB}}$ Input Circuit

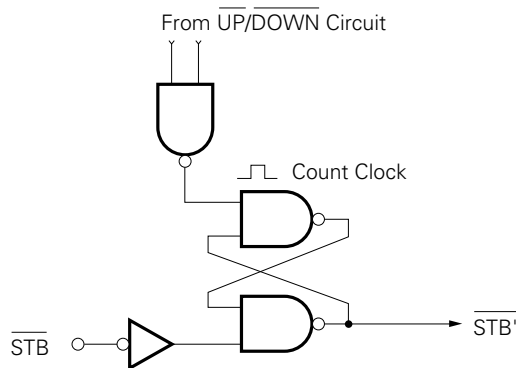

Fig. 2 Relation Between STB Timing and Counter Value

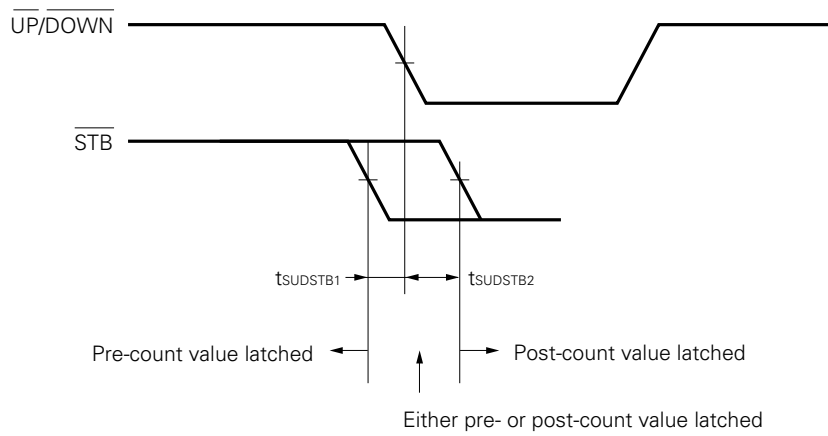
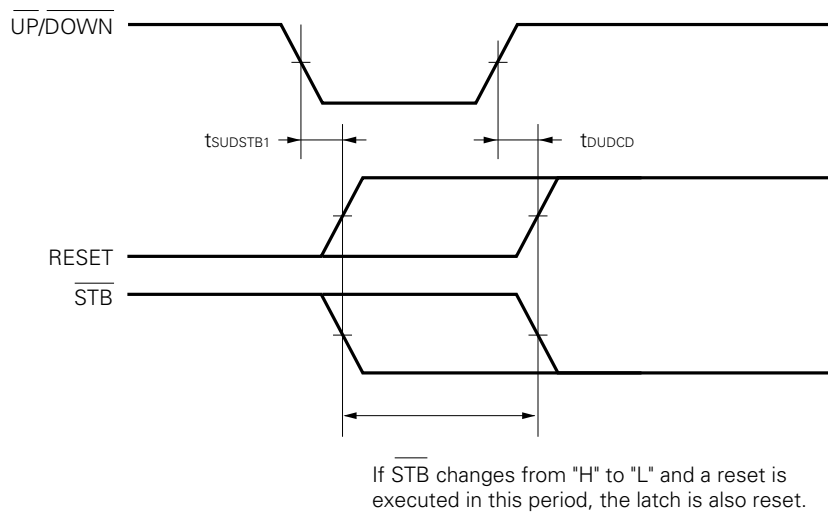

Fig. 3 STB and RESET Timing



(3) Carry & borrow outputs

If the counter performs an up-count operation when the count value is 0FF_H, an active-low pulse is output to the $\overline{\text{Carry}}$ output (the pulse width is virtually the same as the $\overline{\text{UP}}$ or $\overline{\text{DOWN}}$ pulse L period). Similarly, if the counter performs a down-count operation when the count value is 00_H, an active-low pulse is output to the $\overline{\text{Borrow}}$ output. A $\overline{\text{Borrow}}$ pulse is also output if a down-count operation is performed while RESET is "H" (during a reset), and therefore, when a μPD4704 is added, a reset must be executed at the same time.

2. OPERATING PRECAUTIONS

As the μ PD4704 incorporates an 8-bit counter, a large transient current flows in the case of a count value which changes all the bits (such as 00H \leftrightarrow 0FFH or 7FH \leftrightarrow 080H). This will cause misoperation unless the impedance of the power supply line is sufficiently low. It is therefore recommended that a decoupling capacitor (of around 0.1 μ F) be connected between V_{DD} and V_{SS} right next to the IC as shown in Fig. 4.

Fig. 4 Decoupling Capacitor

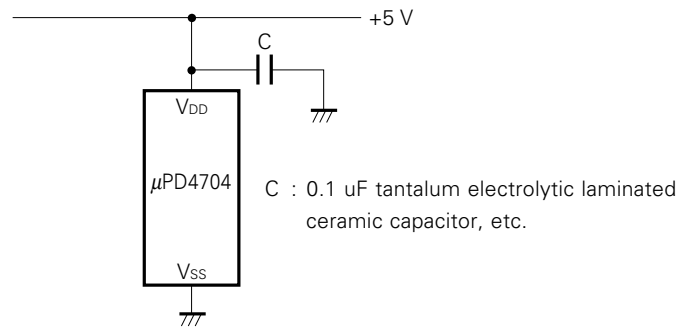

ABSOLUTE MAXIMUM RATINGS (TA = 25 °C, VSS = 0 V)

PARAMETER	SYMBOL	RATING		UNIT
Supply voltage	V _{DD}	-0.5 to +7.0		V
Input voltage	V _I	-1.0 to V _{DD} +1.0		V
Output voltage	V _O	-0.5 to V _{DD} +0.5		V
Operating temperature	T _{opt}	-40 to +85		°C
Storage temperature	T _{stg}	-65 to +150		°C
Permissible loss	P _d	500 (DIP)	200 (SOP)	mW

DC CHARACTERISTICS (TA = -40 to +85 °C, VDD = +5 V ±10 %)

PARAMETER	SYMBOL	TEST CONDITIONS	RATING		UNIT
			MIN.	MAX.	
Input voltage low	V _{IL}			0.8	V
Input voltage high	V _{IH}	Reset	2.6		V
	V _{IH}	Other than the above	2.2		V
Output voltage low	V _{OL}	I _{OL} = 12 mA		0.45	V
Output voltage high	V _{OH}	I _{OH} = -4 mA	V _{DD} - 0.8		V
Static consumption current	I _{DD}	V _I = V _{DD} , V _{SS}		50	μA
Input current	I _I	V _I = V _{DD} , V _{SS}	-1.0	1.0	μA
3-state output leak current	I _{OFF}		-10	10	μA
Dynamic consumption current	I _{DD dyn}	f _{IN} = 16 MHz, C _L = 50 pF		12	mA
Hysteresis voltage	V _H	Reset	0.2		V

AC CHARACTERISTICS (TA = -40 to +85 °C, VDD = +5 V ±10 %)

PARAMETER		SYMBOL	TEST CONDITIONS	MIN.	MAX.	UNIT
$\overline{\text{Up}}$ Down	Cycle	t _{CYCT}	f _{in} = 16 MHz	60		ns
	Input pulse width	t _{PWUDL}		25		ns
		t _{PWUDH}		35		ns
	Setup time	t _{SRSUD}		0		ns
	Up/down switchover setup time	t _{SUDM}		100		ns
CD _{0 to 7}	Reset time	t _{DRSCD}			60	ns
	Output delay	t _{DUDCD}			70	ns
	Output delay	t _{DOECD}			50	ns
	Output delay	t _{DSTBCD}			50	ns
	Float time	t _{FOECD}			40	ns
$\overline{\text{Carry}}$ Borrow	Output delay	t _{DUDCB1}			50	ns
		t _{DUDCB2}			100	ns
	Output pulse width	t _{PWCB}		30		ns
RESET	Reset pulse width	t _{PWRS}		40		ns
$\overline{\text{STB}}$	Setting time	t _{SUDSTB1}		40		ns
		t _{SUDSTB2}		10		ns

AC Timings

Fig. 1 Up/Down Signal Input Timing

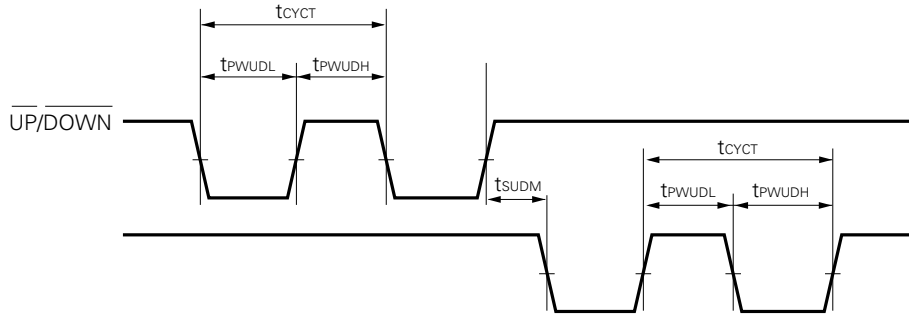

Fig. 2 Count Data Output Timing

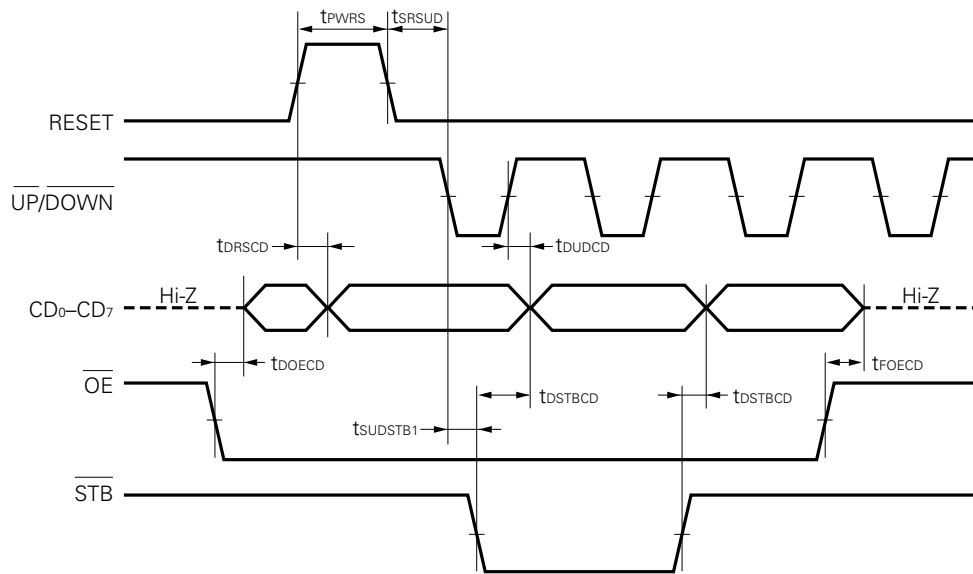

Fig. 3 Carry/Borrow Signal Output Timing

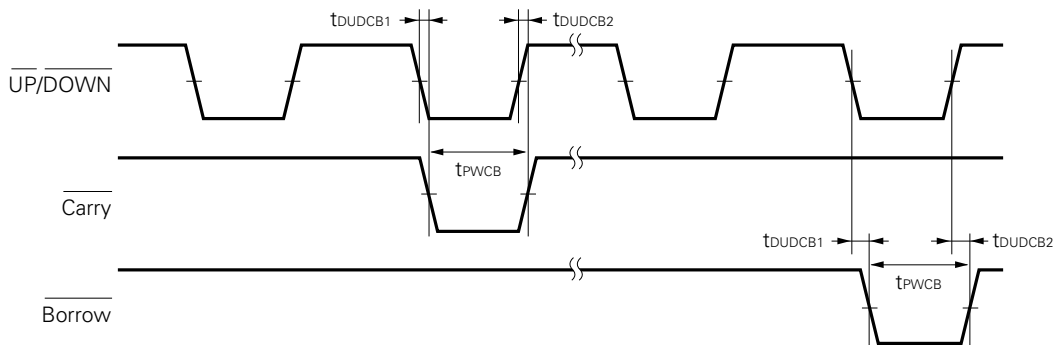
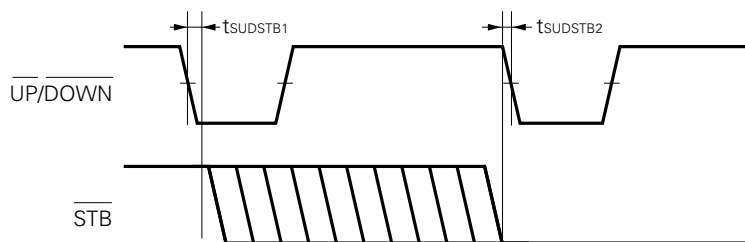
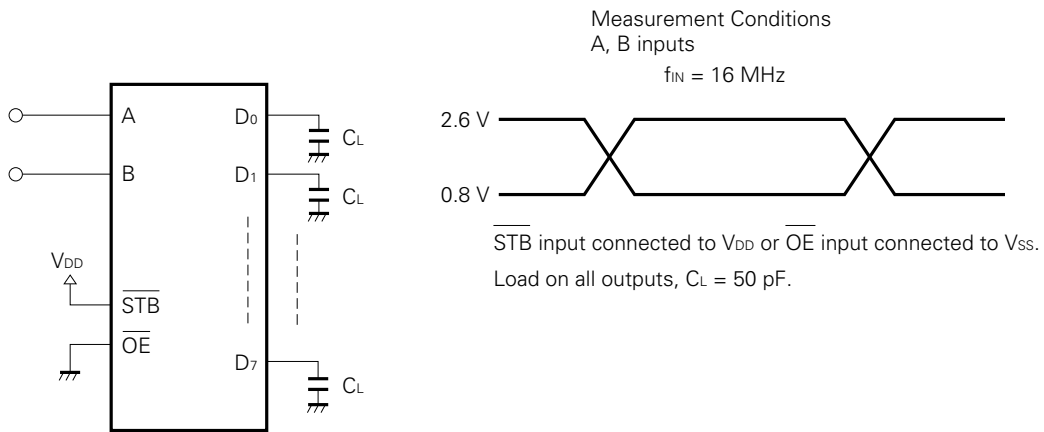

Fig. 4 Strobe Signal Output Timing



Consumption Current Measurement Circuit



AC Test Input Waveform

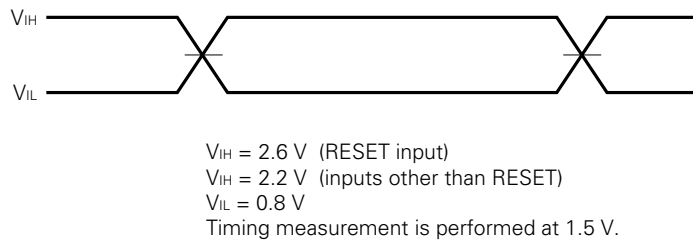

• **3 state output**

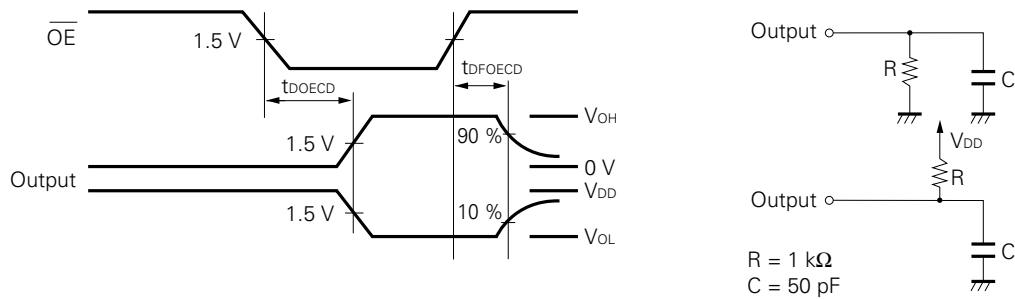

Sample Application Circuits

16-bit counter

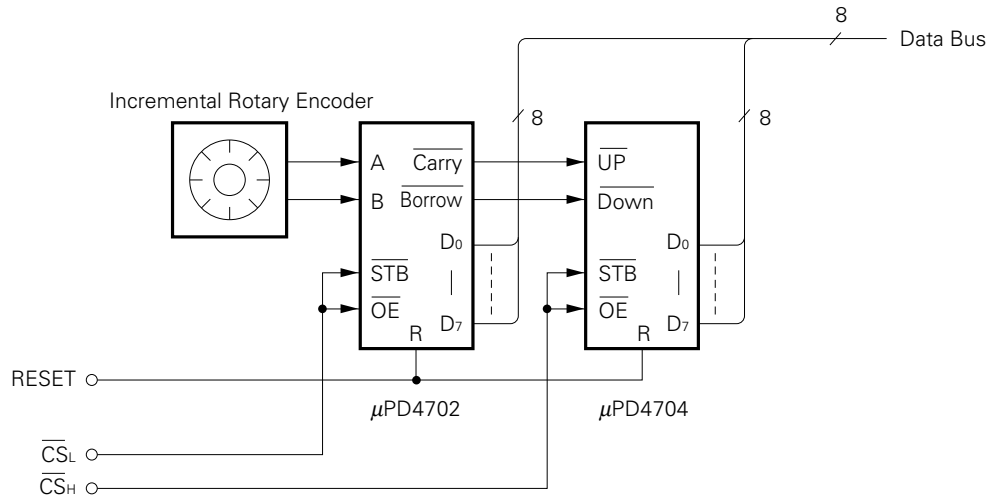

The application circuits and their parameters are for references only and are not intended for use in actual design-in's.

RECOMMENDED SOLDERING CONDITIONS

The following conditions (see table below) must be met when soldering this product.

Please consult with our sales offices in case other soldering process is used, or in case soldering is done under different conditions.

TYPES OF SURFACE MOUNT DEVICE

For more details, refer to our document “Semiconductor Device Mounting Technology Manual” (IEI-1207).

μPD4704G

Soldering process	Soldering conditions	Symbol
Infrared ray reflow	Peak package’s surface temperature: 235 °C or below, Reflow time: 30 seconds or below (210 °C or higher), Number of reflow process: 2, Exposure limit*: None	IR35-00-2
VPS	Peak package’s surface temperature: 215 °C or below, Reflow time: 40 seconds or below (200 °C or higher), Number of reflow process: 2, Exposure limit*: None	VP15-00-2
Wave soldering	Solder temperature: 260 °C or below, Flow time: 10 seconds or below, Number of flow process: 1, Exposure limit*: None	WS60-00-1
Partial heating method	Terminal temperature: 300 °C or below, Flow time: 10 seconds or below, Exposure limit*: None	○

* Exposure limit before soldering after dry-pack package is opened.
Storage conditions: 25 °C and relative humidity at 65 % or less.

Note Do not apply more than a single process at once, except for “Partial heating method”.

TYPES OF THROUGH HOLE MOUNT DEVICE

μPD4704C

Soldering process	Soldering conditions	Symbol
Wave soldering	Solder temperature: 260 °C or below, Flow time: 10 seconds or below	

REFERENCE

Document name	Document No.
NEC semiconductor device reliability/quality control system	IEI-1212
Quality grade on NEC semiconductor devices	IEI-1209
Semiconductor device mounting technology manual	IEI-1207
Semiconductor device package manual	IEI-1213
Guide to quality assurance for semiconductor devices	MEI-1202
Semiconductor selection guide	MF-1134

20PIN PLASTIC DIP (300 mil)

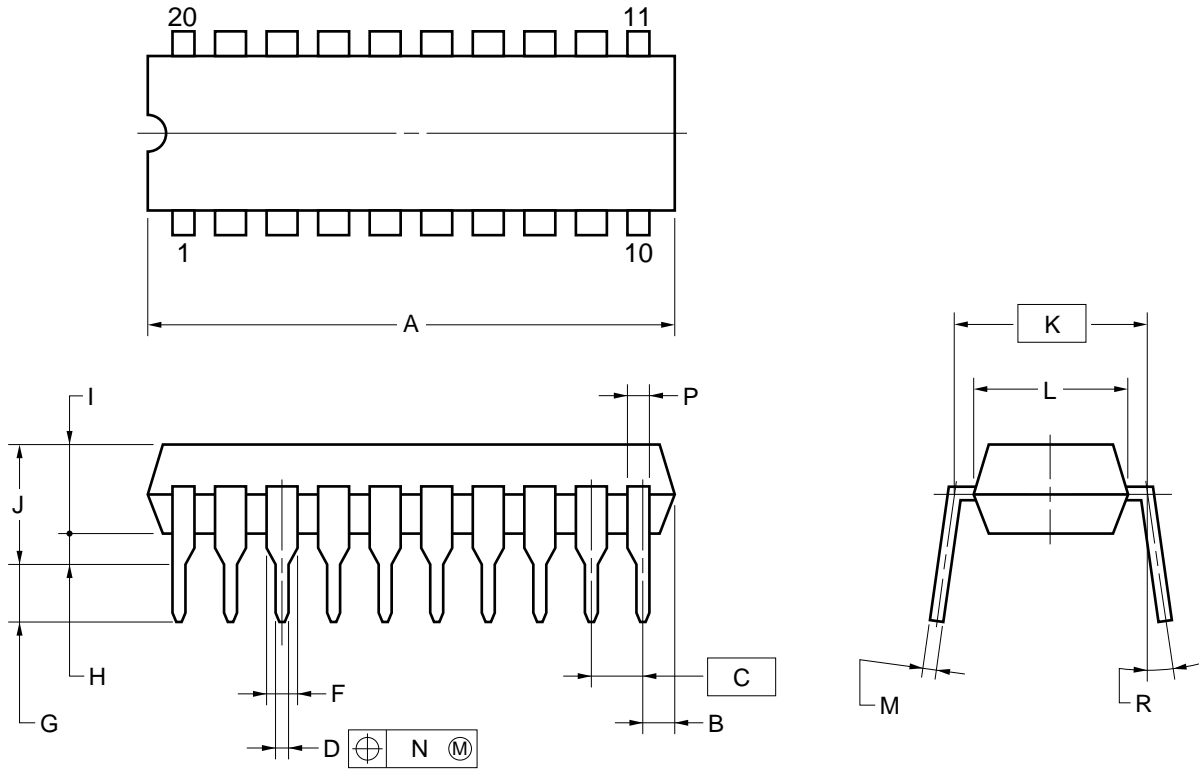

NOTES

- 1) Each lead centerline is located within 0.25 mm (0.01 inch) of its true position (T.P.) at maximum material condition.
- 2) Item "K" to center of leads when formed parallel.

ITEM	MILLIMETERS	INCHES
A	25.40 MAX.	1.000 MAX.
B	1.27 MAX.	0.050 MAX.
C	2.54 (T.P.)	0.100 (T.P.)
D	0.50±0.10	0.020 ^{+0.004} _{-0.005}
F	1.1 MIN.	0.043 MIN.
G	3.5±0.3	0.138±0.012
H	0.51 MIN.	0.020 MIN.
I	4.31 MAX.	0.170 MAX.
J	5.08 MAX.	0.200 MAX.
K	7.62 (T.P.)	0.300 (T.P.)
L	6.4	0.252
M	0.25 ^{+0.10} _{-0.05}	0.010 ^{+0.004} _{-0.003}
N	0.25	0.01
P	0.9 MIN.	0.035 MIN.
R	0~15°	0~15°

P20C-100-300A,C-1

20 PIN PLASTIC SOP (300 mil)

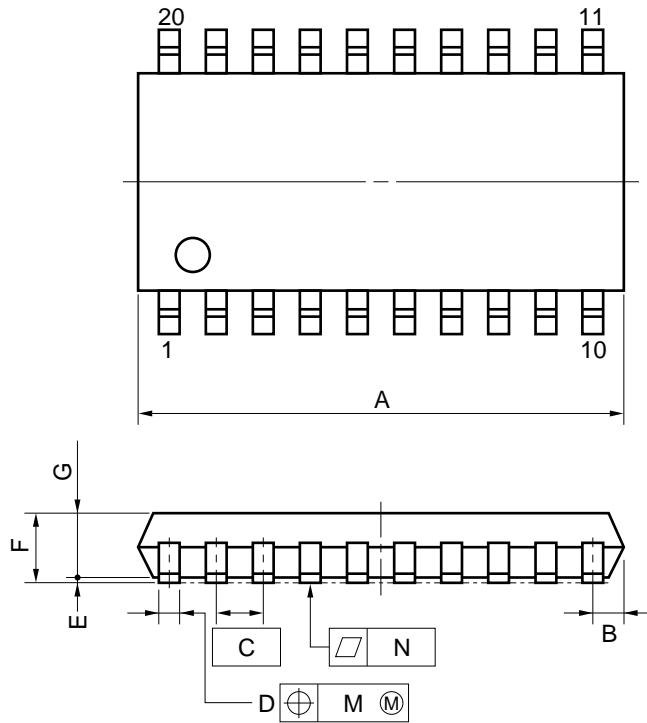

detail of lead end

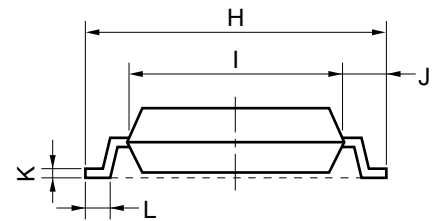
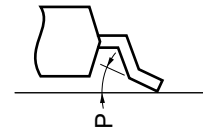

NOTE

Each lead centerline is located within 0.12 mm (0.005 inch) of its true position (T.P.) at maximum material condition.

ITEM	MILLIMETERS	INCHES
A	13.00 MAX.	0.512 MAX.
B	0.78 MAX.	0.031 MAX.
C	1.27 (T.P.)	0.050 (T.P.)
D	0.40 ^{+0.10} _{-0.05}	0.016 ^{+0.004} _{-0.003}
E	0.1±0.1	0.004±0.004
F	1.8 MAX.	0.071 MAX.
G	1.55	0.061
H	7.7±0.3	0.303±0.012
I	5.6	0.220
J	1.1	0.043
K	0.20 ^{+0.10} _{-0.05}	0.008 ^{+0.004} _{-0.002}
L	0.6±0.2	0.024 ^{+0.008} _{-0.009}
M	0.12	0.005
N	0.10	0.004
P	3° ^{+7°} _{-3°}	3° ^{+7°} _{-3°}

P20GM-50-300B, C-4

[MEMO]

[MEMO]

[MEMO]

No part of this document may be copied or reproduced in any form or by any means without the prior written consent of NEC Corporation. NEC Corporation assumes no responsibility for any errors which may appear in this document.

NEC Corporation does not assume any liability for infringement of patents, copyrights or other intellectual property rights of third parties by or arising from use of a device described herein or any other liability arising from use of such device. No license, either express, implied or otherwise, is granted under any patents, copyrights or other intellectual property rights of NEC Corporation or others.

While NEC Corporation has been making continuous effort to enhance the reliability of its semiconductor devices, the possibility of defects cannot be eliminated entirely. To minimize risks of damage or injury to persons or property arising from a defect in an NEC semiconductor device, customers must incorporate sufficient safety measures in its design, such as redundancy, fire-containment, and anti-failure features.

NEC devices are classified into the following three quality grades:

"Standard", "Special", and "Specific". The Specific quality grade applies only to devices developed based on a customer designated "quality assurance program" for a specific application. The recommended applications of a device depend on its quality grade, as indicated below. Customers must check the quality grade of each device before using it in a particular application.

Standard: Computers, office equipment, communications equipment, test and measurement equipment, audio and visual equipment, home electronic appliances, machine tools, personal electronic equipment and industrial robots

Special: Transportation equipment (automobiles, trains, ships, etc.), traffic control systems, anti-disaster systems, anti-crime systems, safety equipment and medical equipment (not specifically designed for life support)

Specific: Aircrafts, aerospace equipment, submersible repeaters, nuclear reactor control systems, life support systems or medical equipment for life support, etc.

The quality grade of NEC devices is "Standard" unless otherwise specified in NEC's Data Sheets or Data Books. If customers intend to use NEC devices for applications other than those specified for Standard quality grade, they should contact an NEC sales representative in advance.

Anti-radioactive design is not implemented in this product.