

NEC

NEC Electronics Inc.

μPD799
2048-BIT CCD
IMAGE SENSOR**PRELIMINARY INFORMATION****Description**

The μPD799 is a CCD (charge-coupled device) linear image sensor that changes optical images to electrical signals. It has 2048 photo-elements, two lines of 1037-bit CCD charge transfer registers, an output amplifier, and a compensation signal amplifier.

The photo-elements have excellent response characteristics because of their PN junction construction. They are 14 by 9 μm separated by 5-μm channel stoppers.

The CCD charge transfer registers have very high transfer efficiency, above 99.996 percent.

Features

- Excellent photo-electrical characteristics
- Single 12-volt power supply
- Compensation amplifier signal can reduce output signal noise
- High resolution of 16 dots per mm across 25.6-cm page
- Transfer efficiency above 99.996 percent
- 24-pin ceramic DIP

Applications

Facsimile
OCR (optical character reader)
Instrumentation

Ordering Information

Part Number	Package	Operating Ambient Temperature
μPD799D	24-pin ceramic DIP	-25 to +55 °C

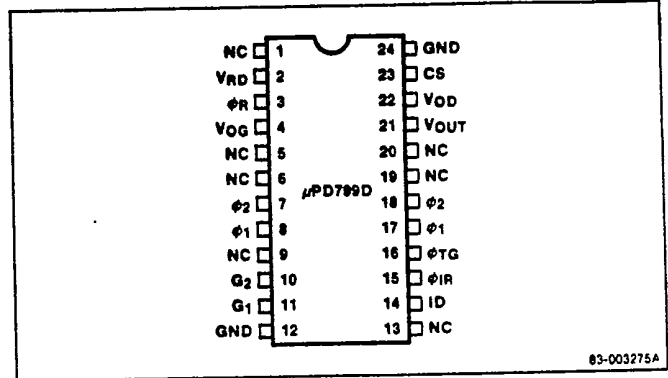
Pin Configuration

63-003275A

Pin Identification

Pin	Name	*Function
1	NC	No connection
2	VRD	Reset part power supply input
3	φR	Reset gate clock input
4	VOG	Output gate bias input
5, 6	NC	No connection
7, 8	φ2, φ1	Register clock input
9	NC	No connection
10	G2	Test input
11	G1	Test input
12	GND	Ground
13	NC	No connection
14	ID	Test input
15	φIR	Test input
16	φTG	Transfer gate clock input
17, 18	φ1, φ2	Register clock input
19, 20	NC	No connection
21	VOUT	Output
22	VOD	Output amplifier power supply input
23	CS	Compensation signal output
24	GND	Ground

*All NC pins should be connected to ground.

μPD799

Block Diagram

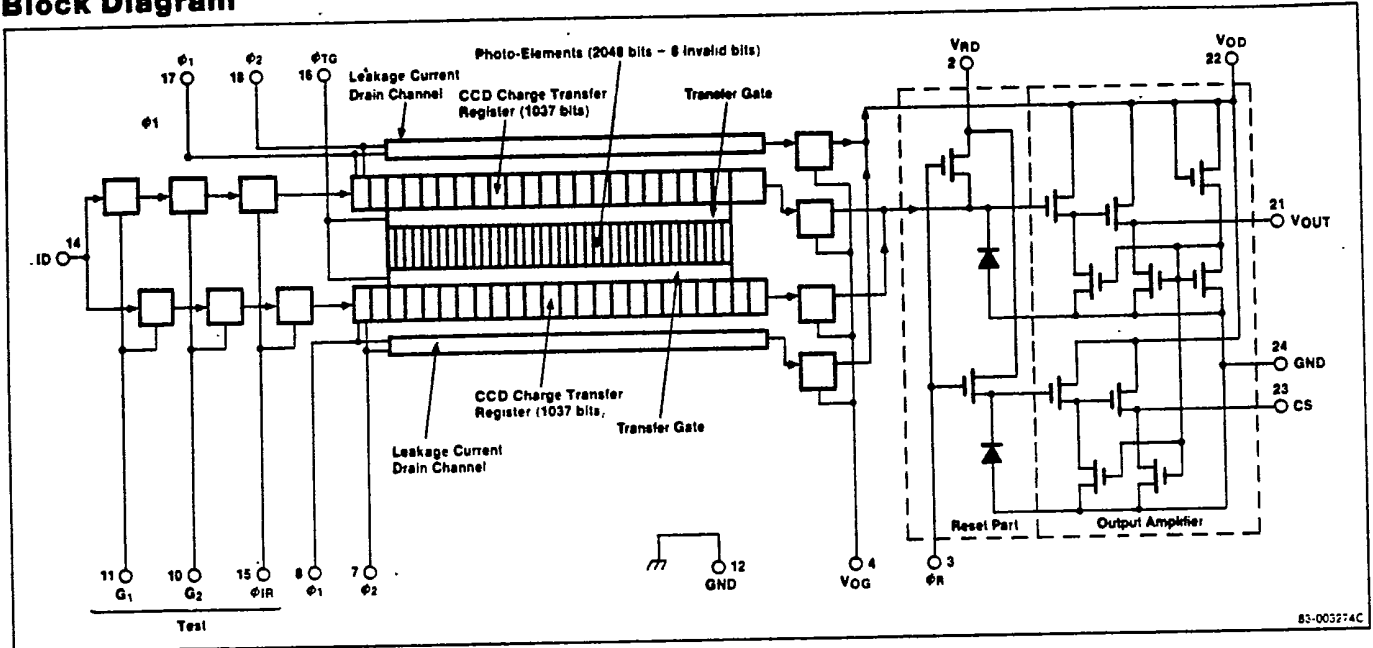
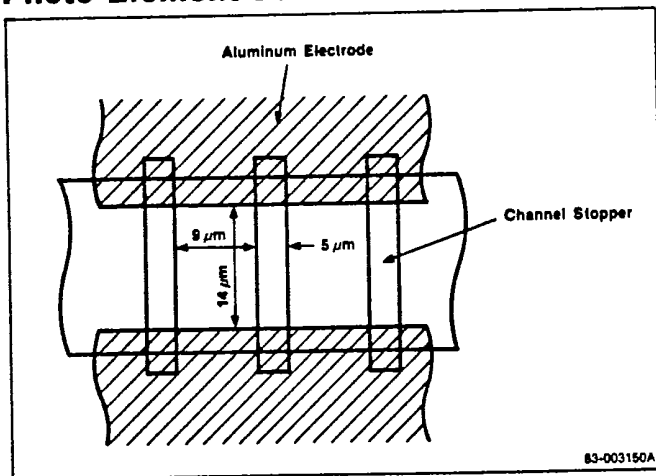

Photo-Element Construction



NEC**μPD799****Electrical Characteristics**

$T_A = +25^\circ\text{C}$; source of light, 2856 K tungsten lamp; exposure period = 5.0 ms; V_{ID} , V_{OD} , and $V_{RD} = 12.0\text{ V}$; $V_{OG} = 2.0\text{ V}$; V_{G1} and $V_{G2} = 0\text{ V}$; $\phi_{TG} = 10\ \mu\text{s}$.

Parameter	Symbol	Limits			Unit	Test Conditions
		Min	Typ	Max		
Saturation Output Voltage	V_{SAT}	400	700		mV	
Saturation Exposure	SE		0.20		ixes	
Photo-Response Nonuniformity	PRNU		± 14	± 20	%	$V_{OUT} = 200\text{ mV}$; infrared cut filter, Corning 1-75
Average Dark Signal	ADS		3	10	mV	No exposure
Dark Signal Nonuniformity	DSNU		5	15	mV	No exposure
Working Power Consumption	P_D	25	45	70	mW	Current of pins 22 and 2 x supply voltage
Spectral Response Range Limits	SR	0.3		1.1	μm	
Sensitivity	S	2000	3500	4500	mV/ixes	
Offset Voltage	V_{IO}	6.5	7.0	8.5	V	0% level of V_{OUT} in timing waveforms
Output Delay Time	t_d		50	120	ns	$t_{\phi F}$ of ϕ_1 and ϕ_2 in timing waveforms = 30 ns

Reference Characteristics

Parameter	Limits			Unit
	Min	Typ	Max	
Input Capacitance at ϕ_1 or ϕ_2 (pins 7, 8, 17, 18)	400	800	1200	pF
Input Capacitance at ϕ_R (pin 3)	5	10	15	pF
Input Capacitance at ϕ_{TG} (pin 16)	20	40	60	pF
Output Impedance at V_{OUT} or CS (pins 21, 23)	1.0	2.0	3.0	k Ω

Absolute Maximum Ratings $T_A = +25^\circ\text{C}$

Output Amplifier Supply Voltage, V_{OD}	-0.3 to +18 V
Reset Part Supply Voltage, V_{RD}	-0.3 to +18 V
Output Gate Voltage, V_{OG}	-0.3 to +18 V
Register Clock Signal Voltage, $V_{\phi 1\phi 2}$	-0.3 to +18 V
Transfer Gate Clock Signal Voltage, $V_{\phi TG}$	-0.3 to +18 V
Reset Gate Clock Signal Voltage, $V_{\phi R}$	-0.3 to +18 V
Operating Temperature, T_{OPT}	-25 to +55 $^\circ\text{C}$
Storage Temperature, T_{STG}	-40 to +100 $^\circ\text{C}$

Comment: Stress above those listed under "Absolute Maximum Ratings" may cause permanent damage to the device. This is a stress rating only and functional operation of the device at these or any other conditions above those indicated in the operational sections of this specification is not implied. Exposure to absolute maximum rating conditions for extended periods may affect device reliability.

Recommended Operating Conditions $T_A = -25$ to $+55^\circ\text{C}$

Parameter	Symbol	Limits			Unit
		Min	Typ	Max	
Output Amplifier Supply Voltage	V_{OD}	11.4	12.0	12.6	V
Reset Part Supply Voltage	V_{RD}	11.4	12.0	12.6	V
Output Gate Bias Voltage	V_{OG}	1.0	2.0	3.0	V
Test Terminal G_1 Voltage	V_{G1}		0		V
Test Terminal G_2 Voltage	V_{G2}		0		V
Test Terminal ID Voltage	V_{ID}	11.4	12.0	12.6	V
Test Terminal ϕ_R Voltage	$V_{\phi R}$		0		V
High Level of Register Clock Signal	$V_{\phi 1\phi 2H}$	9.0	12.0	12.6	V
Low Level of Register Clock Signal	$V_{\phi 1\phi 2L}$	-0.3	0	0.5	V
High Level of Transfer Gate Clock Signal	$V_{\phi TGH}$	9.0	12.0	12.6	V
Low Level of Transfer Gate Clock Signal	$V_{\phi TGL}$	-0.3	0	0.5	V
High Level of Reset Gate Clock Signal	$V_{\phi RH}$	9.0	12.0	12.6	V
Low Level of Reset Gate Clock Signal	$V_{\phi RL}$	-0.3	0	0.5	V
Register Clock Signal Frequency (see Note)	$f_{\phi 1\phi 2}$		0.2	1.75	MHz
Reset Gate Clock Signal Frequency (see Note)	$f_{\phi R}$		0.4	3.5	MHz

Note: At lower frequencies, t_p of output signal is >100 ns. (See Timing Waveforms.)



μPD799

Timing Waveforms

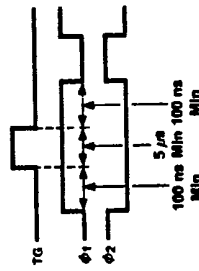
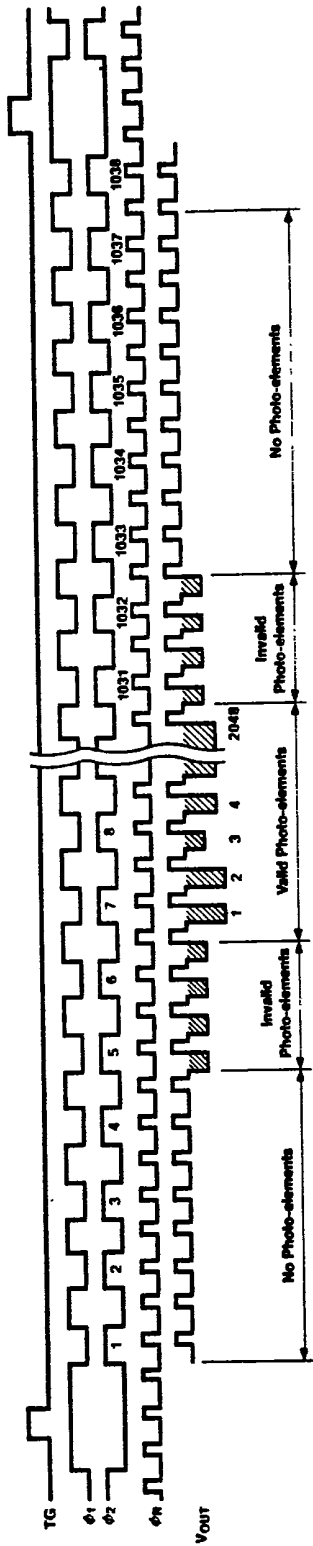

- The crossing voltage of φ1 and φ2 should be kept above $V_{DD} + 1V$.
- The register clock signal should be not more than 1038 cycles.
- Width of the transfer gate pulse should be less than 20 μs.

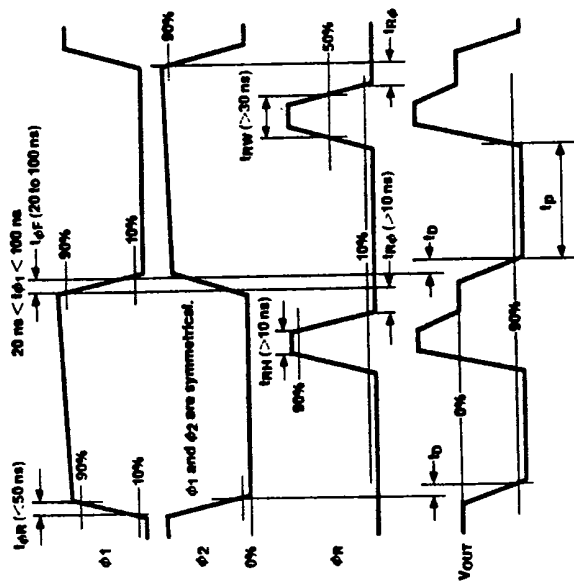

03-003276C

Definitions of Electrical Parameters

Saturation Output Voltage [V_{SAT}]. An output signal level above which the PRNU (photo-response non-uniformity) is ≥10% or the response is nonlinear.

Saturation Exposure [SE]. Product of illuminance (lx) and exposure period (s) in which the output is saturated.

Photo-Response Nonuniformity [PRNU]. Percentage of peak output level and bottom output level against average output level of all valid photo-elements in static and uniform light.

$$PRNU (\%) = \left(\frac{V_{MAX} \text{ OR } V_{MIN}}{\frac{1}{n} \sum_{j=1}^n V_j} - 1 \right) \times 100$$

where
 n = number of valid photo-elements
 V_j = output voltage of each photo element

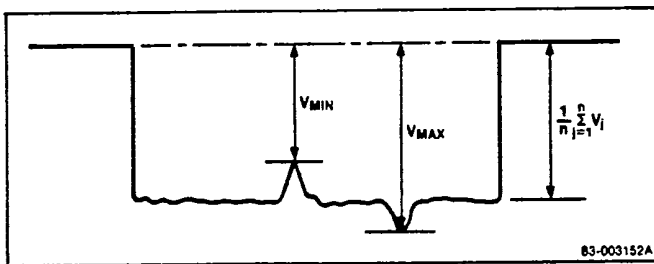

Average Dark Signal [ADS]. Average output level of valid photo-elements with no exposure.

$$ADS (mV) = \frac{1}{n} \sum_{j=1}^n V_j$$

Dark Signal Nonuniformity [DSNU]. Peak output level with no exposure.

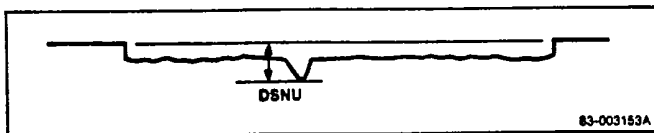

Working Power Consumption [P_W]. Product of supply voltage and current when supply voltage is 12.0 V.

Spectral Response Range Limits [SR]. Short side and long side limits of response spectral range having sensitivity above 5 percent of sensitivity of most sensitive wavelength.

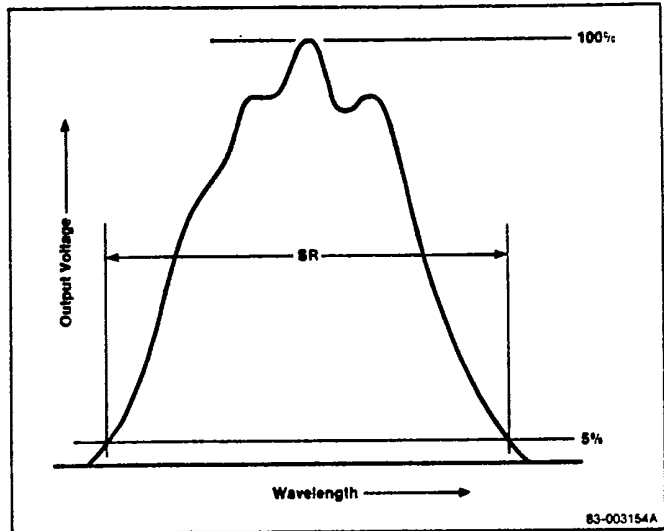

Sensitivity [S]. Quotient of the output level divided by exposure (lx•s).

Offset Voltage [V_{OS}]. Output terminal potential with no exposure.

μPD799

Example of Driving Circuit

(Sheet 1 of 2)

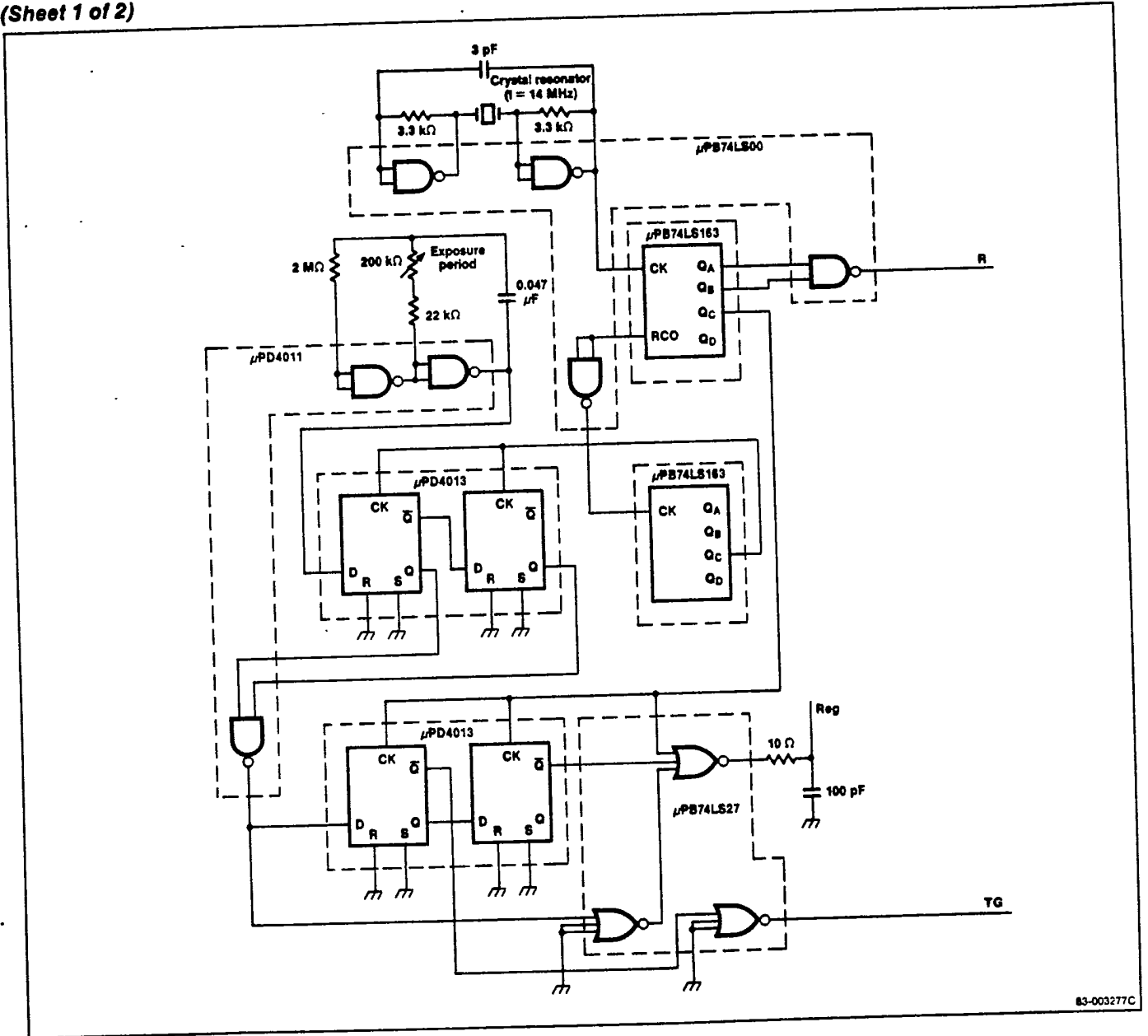

83-003277C

Example of Driving Circuit (Cont.)

(Sheet 2 of 2)

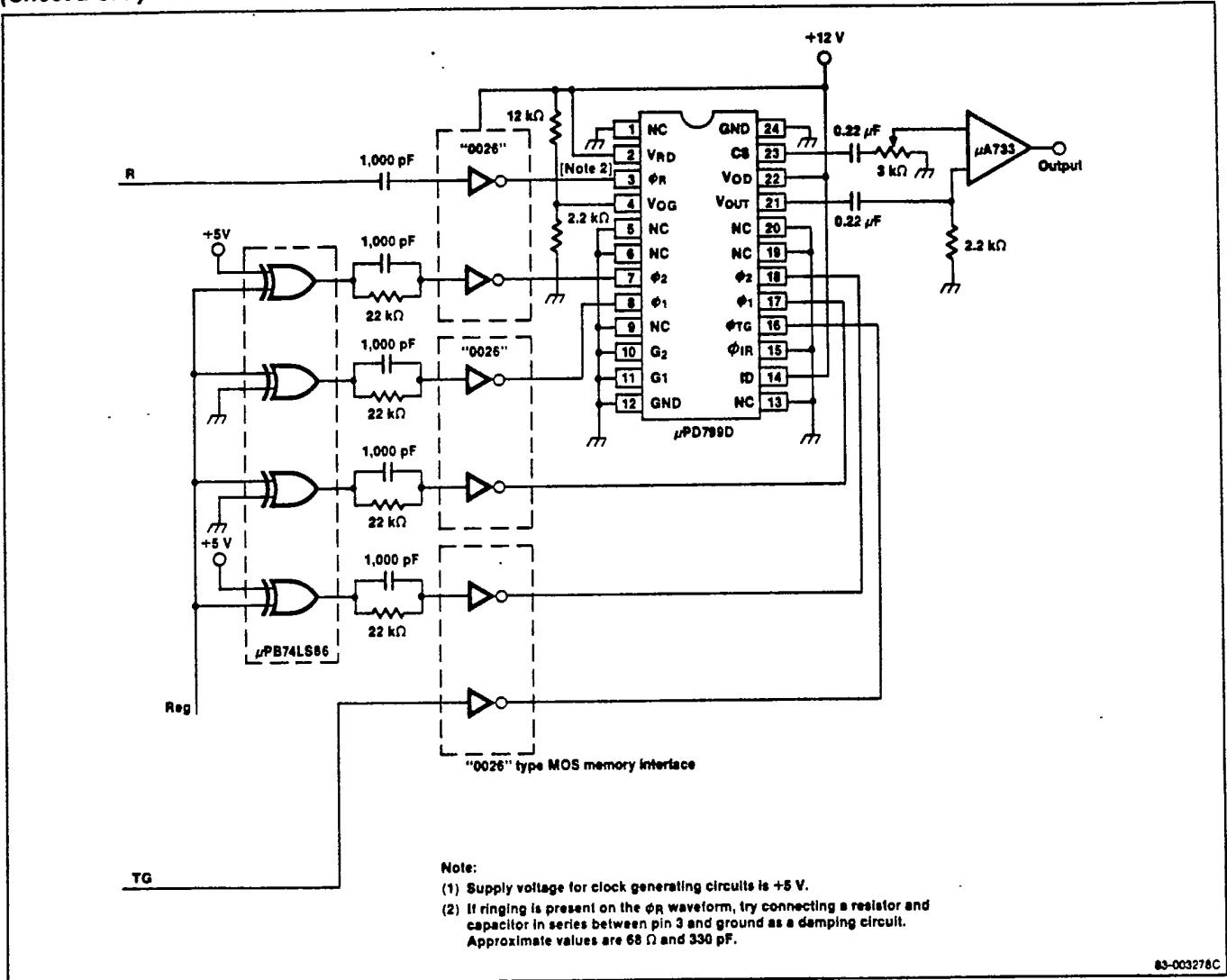



μPD799

Operating Characteristics

T_A = 25°C

Signal Output

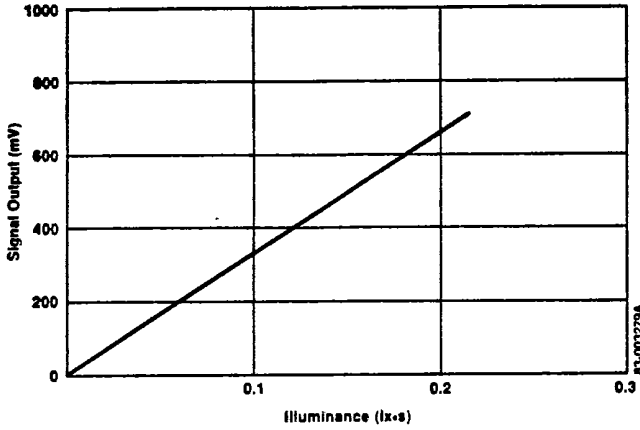

Dark Signal

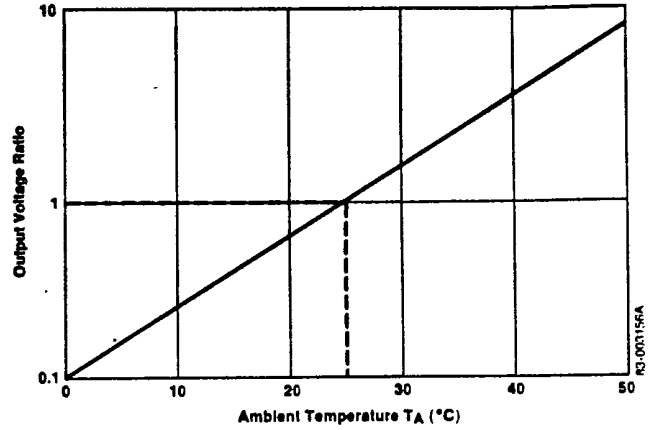

Relative Spectrum Response

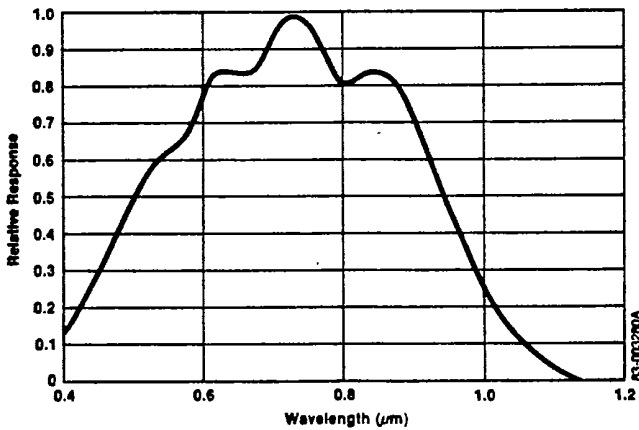

MTF

