

ECL SJ-2830 Series

Rev. E

Description

The **SJ-2830 Series** of quartz crystal oscillators provide F 100k series compatible signals in a ceramic SMD package. Systems designers may now specify space-saving, cost-effective packaged ECL oscillators to meet their timing requirements.

Features

- Wide frequency range—15.0MHz to 250.0MHz
- User specified tolerance available
- Will withstand vapor phase temperatures of 253°C for 4 minutes maximum
- Space-saving alternative to discrete component oscillators
- High shock resistance, to 3000g
- Metal lid electrically connected to ground to reduce EMI
- Low Jitter
- F 100K series compatible output on Pin 3, complement on Pin 1
- High Q Crystal actively tuned oscillator circuit
- Power supply decoupling internal
- No internal PLL avoids cascading PLL problems
- High frequencies due to proprietary design
- Gold plated leads - Solder dipped leads available upon request

Electrical Connection

| Pin | Connection |
|-----|------------------------|
| 1 | Output Complement |
| 2 | V _{EE} -4.5V |
| 3 | Output |
| 4 | V _{CC} Ground |

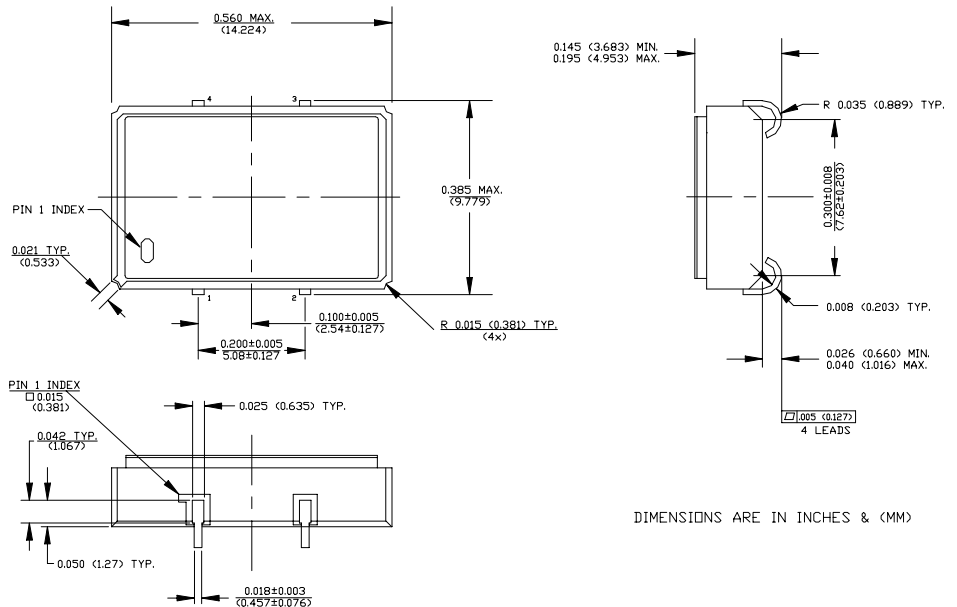

SJ-2830 Series Continued
ECL

Rev. E

Operating Conditions and Output Characteristics

Electrical Characteristics

| Parameter | Symbol | Conditions | Min | Typical | Max |
|------------------------------------|-----------------|--|------------------------|---------|------------------------|
| Frequency | ---- | ---- | 15.0MHz | ---- | 250.0MHz |
| Duty Cycle | ---- | @ V _{CC} -1.29V | 45/55% | ---- | 55/45% |
| Logic 0 ⁽²⁾ | V _{OL} | ---- | V _{CC} -1.95V | ---- | V _{CC} -1.60V |
| Logic 1 ⁽²⁾ | V _{OH} | ---- | V _{CC} -1.02V | ---- | V _{CC} -0.74V |
| Rise & Fall Time | tr,tf | 20-80%V _O with 50 ohm load to V _{CC} -2V | ---- | 1.0 ns | 1.5 ns |
| Tpd ⁽⁴⁾ | ---- | ---- | -0.5 ns | ---- | +0.5 ns |
| Jitter, RMS ⁽³⁾ | ---- | ---- | ---- | ---- | 5 psec |
| Frequency Stability ⁽¹⁾ | dF/F | Overall conditions including: voltage, calibration, temp., 10 yr aging, shock, vibration | -100ppm | ---- | +100ppm |

General Characteristics

| Parameter | Symbol | Conditions | Min | Typical | Max |
|-----------------------|-----------------|---|--------|---------|----------|
| Supply Voltage | V _{EE} | ---- | -4.8V | -4.5V | -4.2V |
| Supply Current | I _{EE} | 50 ohm termination To 2.00V below V _{CC} | 0.0 mA | ---- | 80 mA |
| Output current | I _O | Low level Output Current | 0.0 mA | ---- | ±50.0 mA |
| Operating temperature | T _A | ---- | ---- | ---- | 70°C |
| Storage temperature | T _S | ---- | -55°C | ---- | 125°C |
| Power Dissipation | P _D | ---- | ---- | ---- | 384 mW |
| Lead temperature | T _L | Soldering, 10 sec. | ---- | ---- | 300°C |
| Load | | 50 Ohm to V _{CC} -2V or Thevenin Equivalent, Bias Required | | | |
| Start-up time | t _S | ---- | ---- | 2 ms | 10 ms |

Environmental and Mechanical Characteristics

| | |
|---------------------|--|
| Mechanical Shock | Per MIL-STD-202, Method 213, Condition E |
| Thermal Shock | Per MIL-STD-833, Method 1011, Condition A |
| Vibration | 0.060" double amplitude 10 Hz to 55 Hz, 35g's 55Hz to 2000 Hz |
| Soldering Condition | 300°C for 10 seconds |
| Hermetic Seal | Leak rate less than 1 x 10 ⁻⁸ atm.cc/sec of helium |
| ESD Sensitivity | Human Body Model per ON Semiconductor 10kH series ECL: 500V min. |

Footnotes:

- 1) Standard frequency stability (±20,±25,±50ppm & others available)
- 2) V_{OL}, V_{OH}, referenced to ground (V_{CC}) with V_{EE} = -4.5V
- 3) Jitter performance is frequency dependent. Please contact factory for full characterization.
- 4) Tpd is phase shift between the falling edge of pin 3 at V_{CC}-1.29V and rising edge of pin 1 at V_{CC}-1.29V.

| Creating a Part Number | |
|--------------------------|------------------------------|
| SJ - A283X - FREQ | |
| Package Code | Tolerance/Performance |
| SJ 4 J Lead SMD | 0 ±100ppm 0-70°C |
| | 1 ±50ppm 0-70°C |
| | 7 ±25ppm 0-70°C |
| | 9 Customer Specific |
| Input Voltage | A ±20ppm 0-70°C |
| Code Specification | B ±50ppm -40 to +85°C |
| A 3.3V | C ±100ppm -40 to +85°C |
| 5V | |

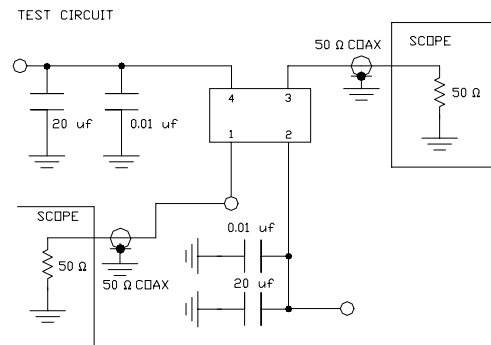

TEST CIRCUIT USES A SPLIT SUPPLY OF +2V AND -2.5V FOR EASE OF TESTING.