

ECL SJ-800 Series

Rev. F

Description

The **SJ-800 Series** of quartz crystal oscillators provide MECL 10K and 10KH series compatible signals in a ceramic SMD package. Systems designers may now specify space-saving, cost-effective packaged ECL oscillators to meet their timing requirements.

Features

- Wide frequency range—18.0MHz to 250.0MHz
- User specified tolerance available
- Will withstand vapor phase temperatures of 253°C for 4 minutes maximum
- Space-saving alternative to discrete component oscillators
- High shock resistance, to 3000g
- Metal lid electrically connected to ground to reduce EMI
- Low Jitter
- MECL 10K and 10KH series compatible output on Pin 3
- High Q Crystal actively tuned oscillator circuit
- Power supply decoupling internal
- No internal PLL avoids cascading PLL problems
- High frequencies due to proprietary design
- Gold plated leads - Solder dipped leads available upon request

Electrical Connection

Pin	Connection
1	N.C.
2	V _{CC} /Ground
3	Output
4	V _{EE} -5.2V

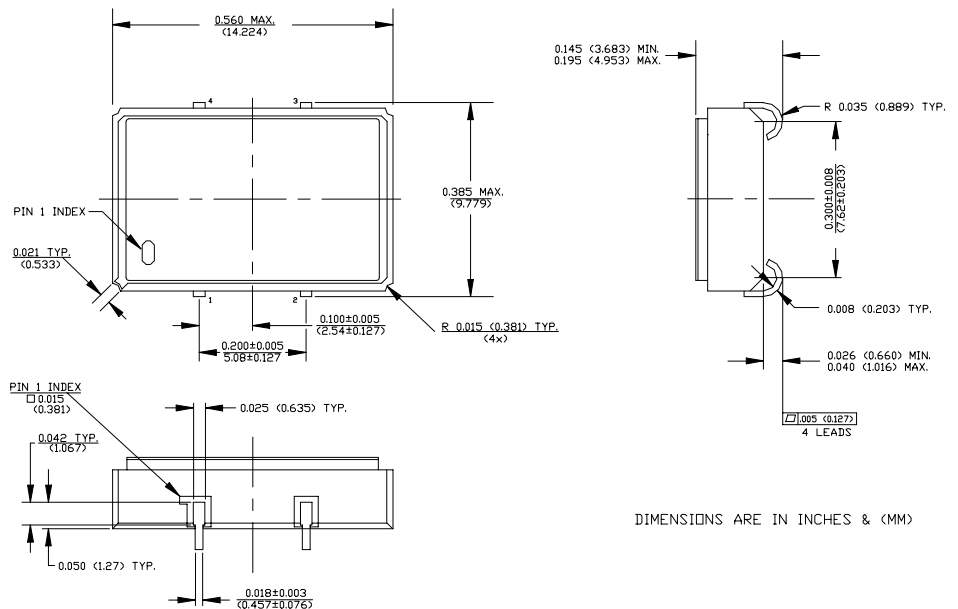

SJ-800 Series Continued
ECL

Rev. F

Operating Conditions and Output Characteristics

Electrical Characteristics

Parameter	Symbol	Conditions	Min	Typical	Max
Frequency	----	----	18.0MHz	----	250.0MHz
Duty Cycle	----	@ $V_{CC}-1.29V$	45/55%	----	55/45%
Logic 0 ⁽²⁾	V_{OL}	----	$V_{CC}-1.95V$	----	$V_{CC}-1.60V$
Logic 1 ⁽²⁾	V_{OH}	----	$V_{CC}-1.02V$	----	$V_{CC}-0.74V$
Rise & Fall Time	tr,tf	20-80% V_O with 50 ohm load to $V_{CC}-2V$	----	1.0 ns	----
Jitter, RMS ⁽³⁾	----	----	----	----	5 psec
Frequency Stability ⁽¹⁾	dF/F	Overall conditions including: voltage, calibration, temp., 10 yr aging, shock, vibration	-100ppm	----	+100ppm

General Characteristics

Parameter	Symbol	Conditions	Min	Typical	Max
Supply Voltage	V_{EE}	----	-5.46V	-5.2V	-4.94V
Supply Current	I_{EE}	50 ohm termination To 2.00V below V_{CC}	0.0 mA	----	80 mA
Output current	I_O	Low level Output Current	0.0 mA	----	±50.0 mA
Operating temperature	T_A	----	0°C	----	70°C
Storage temperature	T_S	----	-55°C	----	125°C
Power Dissipation	P_D	----	----	----	437 mW
Lead temperature	T_L	Soldering, 10 sec.	----	----	300°C
Load		50 Ohm to $V_{CC}-2V$ or Thevenin Equivalent, Bias Required	----	----	----
Start-up time	t_S	----	----	2 ms	10 ms

Environmental and Mechanical Characteristics

Mechanical Shock	Per MIL-STD-202, Method 213, Condition E
Thermal Shock	Per MIL-STD-883, Method 1011, Condition A
Vibration	0.060" double amplitude 10 Hz to 55 Hz, 35g's 55Hz to 2000 Hz
Soldering Condition	300°C for 10 seconds
Hermetic Seal	Leak rate less than 1×10^{-8} atm.cc/sec of helium
ESD Sensitivity	Human Body Model per ON Semiconductor 10kH series ECL: 500V min.

Footnotes:

- 1) Standard frequency stability ($\pm 20, \pm 25, \pm 50$ ppm & others available)
- 2) V_{OL}, V_{OH} , referenced to ground (V_{CC}) with $V_{EE} = -5.2V$
- 3) Jitter performance is frequency dependent. Please contact factory for full characterization.

Creating a Part Number

SJ - A80X - FREQ

<p>Package Code</p> <p>SJ 4 J Lead SMD</p> <p>Input Voltage</p> <table border="0"> <tr> <td>Code</td> <td>Specification</td> </tr> <tr> <td>A</td> <td>3.3V</td> </tr> <tr> <td></td> <td>5V</td> </tr> </table>	Code	Specification	A	3.3V		5V	<p>Tolerance/Performance</p> <p>0 ±100ppm 0-70°C</p> <p>1 ±50ppm 0-70°C</p> <p>7 ±25ppm 0-70°C</p> <p>9 Customer Specific</p> <p>A ±20ppm 0-70°C</p> <p>B ±50ppm -40 to +85°C</p> <p>C ±100ppm -40 to +85°C</p>
Code	Specification						
A	3.3V						
	5V						

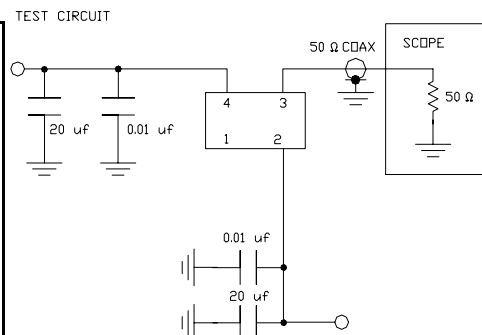

TEST CIRCUIT USES A SPLIT SUPPLY OF +2V AND -3.2V FOR EASE OF TESTING.