

## ECL SJ-2800 Series

Rev. E

### Description

The **SJ-2800 Series** of quartz crystal oscillators provide ECL 10K and 10KH series compatible signals in a ceramic SMD package. Systems designers may now specify space-saving, cost-effective packaged ECL oscillators to meet their timing requirements.

### Features

- Wide frequency range—18.0MHz to 250.0MHz
- User specified tolerance available
- Will withstand vapor phase temperatures of 253°C for 4 minutes maximum
- Space-saving alternative to discrete component oscillators
- High shock resistance, to 3000g
- Metal lid electrically connected to ground to reduce EMI
- Low Jitter
- ECL 10K and 10KH series compatible output on Pin 3, complement on Pin 1
- High Q Crystal actively tuned oscillator circuit
- Power supply decoupling internal
- No internal PLL avoids cascading PLL problems
- High frequencies due to proprietary design
- Gold plated leads - Solder dipped leads available upon request

### Electrical Connection

Pin	Connection
1	Output Complement
2	V <sub>CC</sub> Ground
3	Output
4	V <sub>EE</sub> -5.2V

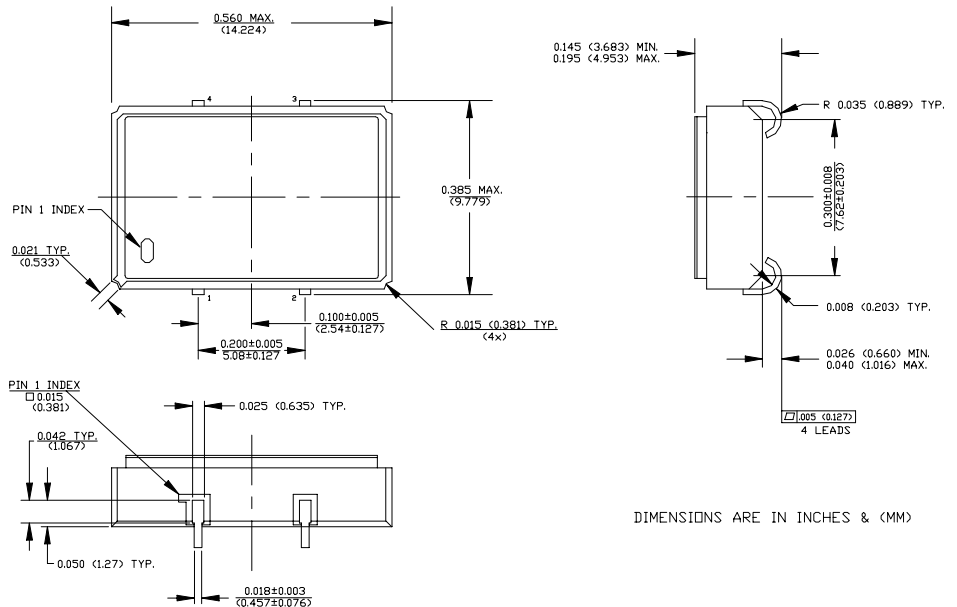

SJ-2800 Series Continued  
ECL

Rev. E

## Operating Conditions and Output Characteristics

### Electrical Characteristics

Parameter	Symbol	Conditions	Min	Typical	Max
Frequency	----	----	18.0MHz	----	250.0MHz
Duty Cycle	----	@V <sub>CC</sub> -1.29V	45/55%	----	55/45%
Logic 0 <sup>(2)</sup>	V <sub>OL</sub>	----	V <sub>CC</sub> -1.95V	----	V <sub>CC</sub> -1.60V
Logic 1 <sup>(2)</sup>	V <sub>OH</sub>	----	V <sub>CC</sub> -1.02V	----	V <sub>CC</sub> -0.74V
Rise & Fall Time	tr,tf	20-80%V <sub>O</sub> with 50 ohm load to V <sub>CC</sub> -2V	----	1.0 ns	1.5 ns
Tpd <sup>(4)</sup>	----	----	-0.5 ns	----	+0.5 ns
Jitter, RMS <sup>(3)</sup>	----	----	----	----	5 psec
Frequency Stability <sup>(1)</sup>	dF/F	Overall conditions including: voltage, calibration, temp., 10 yr aging, shock, vibration	-100ppm	----	+100ppm

### General Characteristics

Parameter	Symbol	Conditions	Min	Typical	Max
Supply Voltage	V <sub>EE</sub>	----	-5.46V	-5.2V	-4.94V
Supply Current	I <sub>EE</sub>	50 ohm termination To 2.00V below V <sub>CC</sub>	0.0 mA	----	80 mA
Output current	I <sub>O</sub>	Low level Output Current	0.0 mA	----	±50.0 mA
Operating temperature	T <sub>A</sub>	----	----	----	70°C
Storage temperature	T <sub>S</sub>	----	-55°C	----	125°C
Power Dissipation	P <sub>D</sub>	----	----	----	437 mW
Lead temperature	T <sub>L</sub>	Soldering, 10 sec.	----	----	300°C
Load		50 Ohm to V <sub>CC</sub> -2V or Thevenin Equivalent, Bias Required	----	----	
Start-up time	t <sub>S</sub>	----	----	2 ms	10 ms

### Environmental and Mechanical Characteristics

Mechanical Shock	Per MIL-STD-202, Method 213, Condition E
Thermal Shock	Per MIL-STD-883, Method 1011, Condition A
Vibration	0.060" double amplitude 10 Hz to 55 Hz, 35g's 55Hz to 2000 Hz
Soldering Condition	300°C for 10 seconds
Hermetic Seal	Leak rate less than 1 x 10 <sup>-8</sup> atm.cc/sec of helium
ESD Sensitivity	Human Body Model per ON Semiconductor 10kH series ECL: 500V min.

#### Footnotes:

- 1) Standard frequency stability (±20,±25,±50ppm & others available)
- 2) V<sub>OL</sub>, V<sub>OH</sub>, referenced to ground (V<sub>CC</sub>) with V<sub>EE</sub> = -5.2V
- 3) Jitter performance is frequency dependent. Please contact factory for full characterization.
- 4) Tpd is phase shift between the falling edge of pin 3 at V<sub>CC</sub>-1.29V and rising edge of pin 1 at V<sub>CC</sub>-1.29V.

#### Creating a Part Number

SJ - A280X - FREQ

#### Package Code

SJ 4 J Lead SMD

#### Tolerance/Performance

- 0 ±100ppm 0-70°C
- 1 ±50ppm 0-70°C
- 7 ±25ppm 0-70°C
- 9 Customer Specific
- A ±20ppm 0-70°C
- B ±50ppm -40 to +85°C
- C ±100ppm -40 to +85°C

#### Input Voltage

Code	Specification
A	3.3V
	5V

#### TEST CIRCUIT

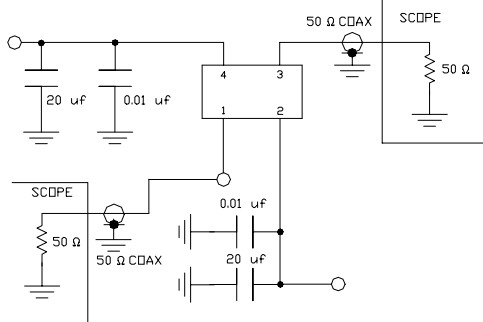

TEST CIRCUIT USES A SPLIT SUPPLY OF +2V AND -3.2V FOR EASE OF TESTING.



**FREQUENCY  
CONTROLS, INC.**

357 Beloit Street, P.O. Box 457, Burlington, WI 53105-0457 U.S.A. Phone 262/763-3591 FAX 262/763-2881

Email: [nelsales@nelfc.com](mailto:nelsales@nelfc.com) www.nelfc.com