



CMOS HA-A1440 Series

Rev. F

Description

The **HA-A1440 Series** of quartz crystal oscillators provide enable/disable 3-state CMOS compatible signals for bus connected systems. Supplying Pin 1 of the HA-A1440 units with a logic "1" or open enables its pin 5 output. In the disabled mode, pin 5 presents a high impedance to the load.

Features

- Wide frequency range– 70.1MHz to 125.0MHz
- User specified tolerance available
- Will withstand vapor phase temperatures of 253°C for 4 minutes maximum
- Space-saving alternative to discrete component oscillators
- High shock resistance, to 3000g
- All metal, resistance weld, hermetically sealed package
- 3.3 Volt operation
- Low Jitter
- High Q Crystal actively tuned oscillator circuit
- Power supply decoupling internal
- No internal PLL avoids cascading PLL problems
- Low power consumption
- Gold plated leads - Solder dipped leads available upon request

Electrical Connection

Pin	Connection
1	Enable Input
4	Grd & Case
5	Output
8	V _{DD}

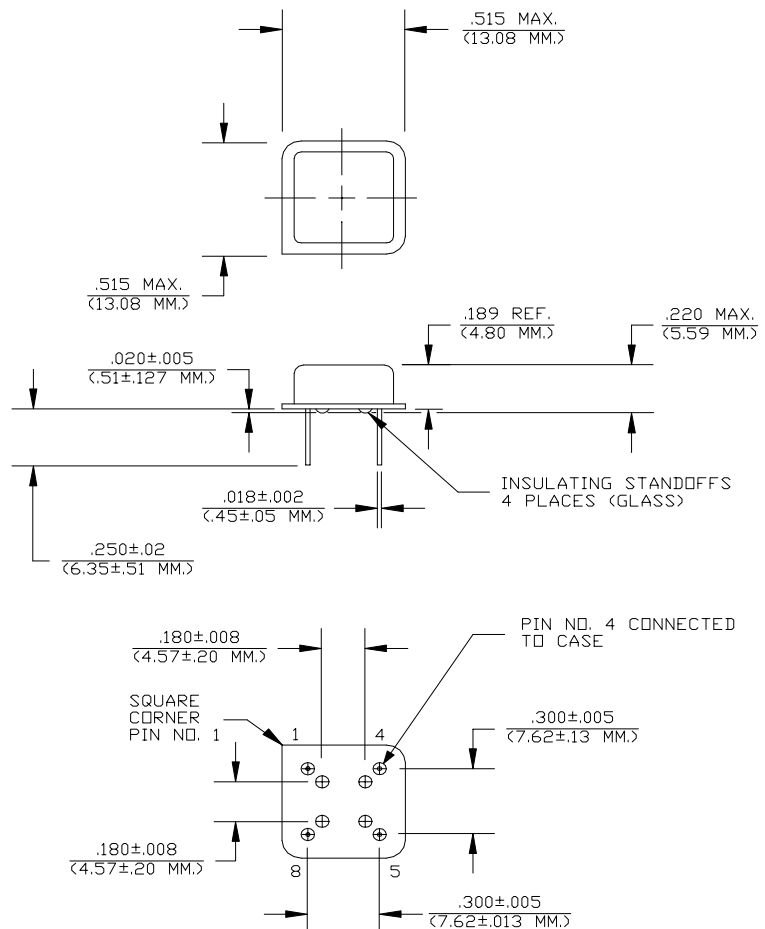

Dimensions are in inches and (MM)

HA-A1440 Series Continued
CMOS

Rev. E

Operating Conditions and Output Characteristics

Electrical Characteristics

Parameter	Symbol	Conditions	Min	Typical	Max
Frequency	----	----	70.1MHz	----	125.0MHz
Duty Cycle	----	@ V _{DD} /2	45/55%	----	55/45%
Logic 0	V _{OL}	@ 600μA	----	0.1V	0.2V
Logic 1	V _{OH}	@ 600μA	V _{DD} -0.2V	V _{CD} -0.1V	----
Rise & Fall Time	tr,tf	10-90%	----	1 ns	2 ns
Tpz	----	----	----	----	100 ns
Jitter, RMS ⁽²⁾	----	----	----	----	5 psec
Frequency Stability ⁽¹⁾	dF/F	Overall conditions including: voltage, calibration, temp., 10 yr aging, shock, vibration	-100ppm	----	+100ppm

General Characteristics

Parameter	Symbol	Conditions	Min	Typical	Max
Supply Voltage	V _{DD}	----	3.135V	3.3V	3.465V
Supply Current	I _{DD}	No Load	0.0 mA	40mA	60mA
Output current	I _O	----	0.0 mA	----	±25.0 mA
Operating temperature	T _A	----	0°C	----	70°C
Storage temperature	T _S	----	-55°C	----	125°C
Power Dissipation	P _D	----	----	----	277 mW
Lead temperature	T _L	Soldering, 10 sec.	----	----	300°C
Load	----	----	----	----	15pf
Start-up time	t _s	----	----	2 ms	10 ms

Environmental and Mechanical Characteristics

Mechanical Shock	Per MIL-STD-202, Method 213, Condition E
Thermal Shock	Per MIL-STD-833, Method 1011, Condition A
Vibration	0.060" double amplitude 10 Hz to 55 Hz, 35g's 55Hz to 2000 Hz
Soldering Condition	300°C for 10 seconds
Hermetic Seal	Leak rate less than 1 x 10 ⁻⁸ atm.cc/sec of helium

Footnotes:

- 1) Standard frequency stability (±20,±25,±50ppm & others available)
- 2) Jitter performance is frequency dependent. Please contact factory for full characterization.

Creating a Part Number

HA - A144X - FREQ

Package Code

HA Ledged 4 pin (8 pin)
SA Ledged 4 pin (8 pin) SMD
Gull Wing

Input Voltage

Code Specification
A 3.3V
5V

Tolerance/Performance

0 ±100ppm 0-70°C
1 ±50ppm 0-70°C
7 ±25ppm 0-70°C
9 Customer Specific
A ±20ppm 0-70°C
B ±50ppm -40 to +85°C
C ±100ppm -40 to +85°C

Test Load:

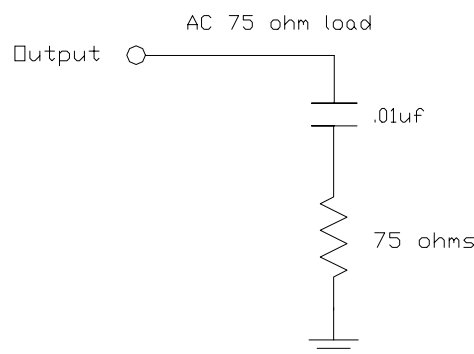

**FREQUENCY
CONTROLS, INC.**