



CMOS HA-A390 Series

Rev. C

Description

The **HA-A390 Series** of quartz crystal oscillators provide CMOS compatible signals for general purpose timing applications.

Features

- Wide frequency range—70.1MHz to 125.0MHz
- User specified tolerance available
- Will withstand vapor phase temperatures of 253°C for 4 minutes maximum
- Space-saving alternative to discrete component oscillators
- High shock resistance, to 3000g
- 3.3 volt operation
- Low Jitter
- High Q Crystal actively tuned oscillator circuit
- Power supply decoupling internal
- No internal PLL avoids cascading PLL problems
- High frequencies due to proprietary design
- All metal, resistance weld, hermetically sealed package
- Gold plated leads - Solder dipped leads available upon request

Electrical Connection

Pin	Connection
1	N.C.
4	Grd & Case
5	Output
8	V _{DD}

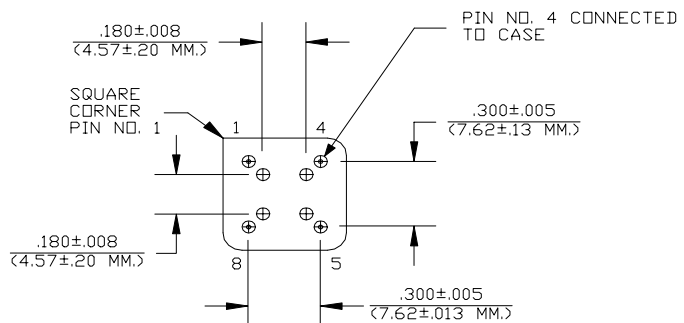
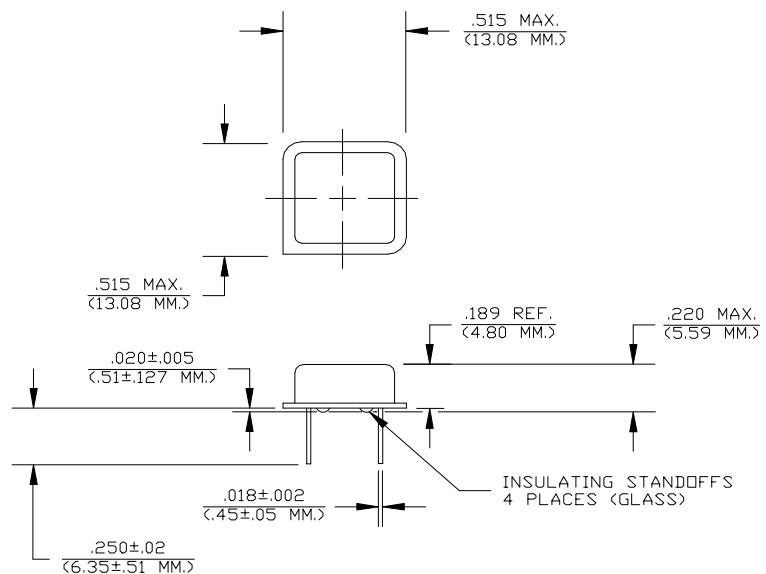

Dimensions are in inches and MM.

HA-A390 Series Continued
CMOS

Rev. C

Operating Conditions and Output Characteristics

Electrical Characteristics

Parameter	Symbol	Conditions	Min	Typical	Max
Frequency	----	----	70.1MHz	----	125.0MHz
Duty Cycle	----	@ $V_{DD}/2$	45/55%	----	55/45%
Logic 0	V_{OL}	@ 600 μ A	----	0.1V	0.2V
Logic 1	V_{OH}	@ 600 μ A	$V_{DD}-0.2V$	$V_{DD}-0.1V$	----
Rise & Fall Time	tr,tf	10-90% V_O	----	1 ns	2 ns
Jitter, RMS ⁽²⁾	----	----	----	----	5 psec
Frequency Stability ⁽¹⁾	dF/F	Overall conditions including: voltage, calibration, temp., 10 yr aging, shock, vibration	-100ppm	----	+100ppm

General Characteristics

Parameter	Symbol	Conditions	Min	Typical	Max
Supply Voltage	V_{DD}	----	3.135V	3.3V	3.465V
Supply Current	I_{DD}	No Load	0.0 mA	40 mA	60 mA
Output current	I_O	----	0.0 mA	----	± 25.0 mA
Operating temperature	T_A	----	0°C	----	70°C
Storage temperature	T_S	----	-55°C	----	125°C
Power Dissipation	P_D	----	----	----	208 mW
Lead temperature	T_L	Soldering, 10 sec.	----	----	300°C
Load	----	----	----	----	15pf
Start-up Time	t_s	----	----	----	10 ms

Environmental and Mechanical Characteristics

Mechanical Shock	Per MIL-STD-202, Method 213, Condition E
Thermal Shock	Per MIL-STD-883, Method 1011, Condition A
Vibration	0.060" double amplitude 10 Hz to 55 Hz, 35g's 55Hz to 2000 Hz
Soldering Condition	300°C for 10 seconds
Hermetic Seal	Leak rate less than 1×10^{-8} atm.cc/sec of helium

Footnotes:

- 1) Standard frequency stability ($\pm 20, \pm 25, \pm 50$ ppm & others available)
- 2) Jitter performance is frequency dependent. Please contact factory for full characterization.

Creating a Part Number

HA - A39X - FREQ

Package Code

HA Leaded 4 pin (8 pin)
SA Leaded 4 pin (8 pin) SMD
Gull Wing

Input Voltage

Code Specification
A 3.3V
5V

Tolerance/Performance

0 ± 100 ppm 0-70°C
1 ± 50 ppm 0-70°C
7 ± 25 ppm 0-70°C
9 Customer Specific
A ± 20 ppm 0-70°C
B ± 50 ppm -40 to +85°C
C ± 100 ppm -40 to +85°C

Test Load:

